



Eric VanRuymbeke
Sr. Advisor
Leave to Construct Applications
Regulatory Affairs

tel 519-436-4600 x5002241
eric.vanruymbeke@enbridge.com
EGIRegulatoryProceedings@enbridge.com

Enbridge Gas Inc.
50 Keil Drive North,
Chatham, Ontario
N7M 5M1

VIA EMAIL and RESS

May 18, 2023

Nancy Marconi
Registrar
Ontario Energy Board
2300 Yonge Street, Suite 2700
Toronto, Ontario, M4P 1E4

Dear Nancy Marconi:

**Re: Enbridge Gas Inc. (“Enbridge Gas” or the “Company”)
Ontario Energy Board (“OEB”) File Nos.
EB-2022-0156 – Selwyn Pipeline Project (“SPP”)
EB-2022-0248 – Mohawks of the Bay of Quinte First Nation Pipeline Project
(“MBQFNPP”)
EB-2022-0249 – Hidden Valley Pipeline Project (“HVPP”)
Updated Interrogatory Responses**

Enbridge Gas is in receipt of Environmental Defence’s (“ED”) May 4, 2023 e-mail, which posed several questions related to the Company’s May 2, 2023 interrogatory responses in the above noted proceedings. Upon further review, the Company is filing updates to the following interrogatory responses:

- EB-2022-0156 Exhibit I.ED.5, Attachment 2,
- EB-2022-0249 Exhibit I.ED.5, Attachment 4, and
- EB-2022-0156/EB-2022-0248/EB-2022-0249 Exhibit I.ED.15.

In its correspondence, ED also requested that Enbridge Gas provide updated responses to several interrogatories to confirm details of available grants and subsidies for non-natural gas alternatives.¹ Within Enbridge Gas’s May 2 responses to those interrogatories, the Company confirmed the information for programs that it is directly engaged in. Enbridge Gas cannot reasonably confirm details for programs it does not administer as program eligibility criteria can be complex and can change without the Company’s knowledge. Enbridge Gas did however provide links to publicly available information that the Company is aware of regarding the information sought by ED. As such, there are no updates the Company can provide to its responses for those interrogatories.

ED’s correspondence also requested that Enbridge Gas provide updated responses to several interrogatories to provide information regarding attachment scenarios at 50% of

¹ EB-2022-0156/EB-2022-0248/EB-2022-0249 Exhibit I.ED.17, part a); EB-2022-0156/EB-2022-0248/EB-2022-0249 Exhibit I.ED.20, parts a) – d); and EB-2022-0156/EB-2022-0248/EB-2022-0249 Exhibit I.ED.21, parts a) – b).

those established by the Company.² Within Enbridge Gas's May 2 responses to those interrogatories, the Company did not provide the information as the scenario suggested by ED is arbitrary and without basis. Enbridge Gas also stated, and continues to believe, that the requested information could likely only be used to draw oversimplified conclusions, as any adjustments made to the attachment forecast would result in other Project components/scope being reassessed and adjusted accordingly. Enbridge Gas reiterates that its attachment forecasts are based on the actual energy interests expressed by residents and business-owners within the Project areas, which inherently incorporate all factors including financial and non-financial considerations. Based on the foregoing, the Company has no reason to believe that its attachment forecasts are inaccurate and declines to provide the requested information based on the speculative scenarios suggested by ED.

ED's correspondence also requested that Enbridge Gas provide additional information regarding an updated response to an interrogatory that the Company indicated it would file by May 31, 2023.³ In this regard, Enbridge Gas has provided further relevant information in its May 16, 2023 letter which was submitted in response to Pollution Probe's May 9, 2023 letter.

Sincerely,

Eric VanRuymbeke
Sr Advisor, Leave to Construct Applications

c.c. Charles Keizer (Torys)
Henry Ren (Enbridge Gas Counsel)
Guri Pannu (Enbridge Gas Counsel)
Catherine Nguyen (OEB Staff)
Zora Crnojacki (OEB Staff)
Petar Prazic (OEB Staff)
Intervenors (EB-2022-0156/EB-2022-0248/EB-2022-0249)

² EB-2022-0156/EB-2022-0248/EB-2022-0249 Exhibit I.ED.13; and EB-2022-0156/EB-2022-0248/EB-2022-0249 Exhibit I.ED.14

³ EB-2022-0156/EB-2022-0248/EB-2022-0249 Exhibit I.ED.16, part e).

ENBRIDGE GAS INC.

Answer to Interrogatory from
OEB Staff ("STAFF")

INTERROGATORY

Reference:

Exhibit B, Tab 1, Schedule 1, page 2 of 9, paragraph 8 and 9 Attachment 3: Mohawks of the Bay of Quinte & Tyendinaga Township Natural Gas Questionnaire

Enbridge Gas administered a questionnaire to determine the interest for converting to natural gas. Enbridge Gas distributed the questionnaire at the Fall Fair on September 9 and September 10, 2022. It was also distributed door-to-door to all residents and commercial businesses during the week of September 12, 2022. Enbridge Gas received 68 responses as of October 12, 2022.

Question:

- a) Which method Enbridge Gas used to collect the responses to the questionnaires?
- b) What was the response rate to the questionnaire? Please compare the response rate to response rates in recent market surveys conducted for or retained by Enbridge Gas for other Phase II community expansion projects?
- c) How many questionnaires were distributed respectively in the Mohawks of the Bay of Quinte community and in the Shannonville community? How many responses were received in each community? What was the response rate in each community?
- d) Since the completion of the market research survey on October 12, 2022, has Enbridge Gas obtained additional information on the interest for switching to natural gas service as part of this community expansion project. Please discuss.

Response

- a) Enbridge Gas distributed hardcopy (paper) letters door-to-door to residents and commercial establishments in the project area and to attendees of the community's Fall Fair.¹
- b) There were 68 responses received from the residences and businesses visited and attendees at the Fall Fair, resulting in a response rate of 24% for the Questionnaire. Surveys have not been completed for every community selected for funding in the second phase of the NGEP. Among eight "Phase 2" communities surveyed by Forum Research in 2022, the response rate ranged from 16% to 54%, with an average response rate of 37%. This is consistent with the average response rate from the previous group of surveys completed by Forum Research in 2020. The average response rate for the 2020 surveys was 39%, with a range of 17% - 64%.
- c) There were approximately 229 questionnaires distributed in the Mohawks of the Bay of Quinte community and 44 in the Shannonville community. The overall response rate for the Project Area can be found in the response to part b). Enbridge Gas did not explicitly collect addresses (including municipality) or names on the questionnaires and therefore, cannot calculate the response rate based on zones within the Project Area.

Additionally, to date Enbridge Gas has received expressions of interest from 103 customers within the Project area, 91 in MBQ and 12 in Shannonville.

- d) Yes. Enbridge Gas held the following in-person public information sessions within the Project area since October 2022:²
 - Customer Kiosk, February 1 – 2, 2023
 - Community presentation, April 12, 2023
 - Customer Kiosk, April 19, 2023

Enbridge Gas also meets often with MBQ council members regarding conversion of band-owned residential and commercial buildings. Through these discussions, MBQ chief and council have indicated that all band-owned buildings will convert to natural gas.³

Enbridge Gas has also conducted a door-to-door Expression of Interest ("EOI") survey between December 14 and 16, 2022, to supplement the Questionnaire and to

¹ Exhibit B, Tab 1, Schedule 1, p. 2, para. 8; Exhibit B, Tab 1, Schedule 1, Attachment 3

² Please see the response to EB-2022-0249, Exhibit I.ED.28 part b), for the Customer Attachment Package, and Kiosk and D2D Dropoff Assets materials used in the public information sessions.

³ Exhibit B, Tab 1, Schedule 1, Attachment 5

answer questions related to the Project. As of March 30, 2023, 103 EOI responses confirming interest in receiving natural gas services have been collected (12 from Shannonville and 91 from MBQ, not including 24 band owned properties expected to attach). This EOI outcome represents over 60% of the 10-year attachment forecast, exceeding the cumulative year 3 attachment forecast.⁴ Expressions of interest are a precursor to completed attachment applications and therefore provide a strong indication of early attachment numbers and expected trends in natural gas conversion within the community going forward. Please see the responses at Exhibit I.ED.5 and at EB-2022-0249 Exhibit I.ED.28, for additional explanation and materials related to the door-to-door EOI.

Enbridge Gas also commenced ongoing attachment outreach in the Project area on January 24, 2023 and will continue these efforts throughout Project execution.

⁴ 103 out of 179 (minus 24 band owned buildings) (10yr forecast) = 66% interest

ENBRIDGE GAS INC.

Answer to Interrogatory from
OEB Staff ("STAFF")

INTERROGATORY

Reference:

Exhibit B, Tab 1, Schedule 1, page 1 of 9, paragraph 1; pages 7 and 8 of 9, paragraphs 16 and 17, Table 2: Forecasted Customer Attachments for the Project

Enbridge Gas plans the Project's in-service date to be December 2023. Enbridge Gas forecasted attachments of 151 customers in the community of Mohawks of the Bay of Quinte (138 residential and 13 commercial and industrial) and 28 residential customers in Shannonville in the next ten years.

Table below shows forecasted attachments over ten years annually starting in 2023. Enbridge Gas indicated that the forecasted attachment assumed a 65% capture rate by the end of 2032.

Table 2: Forecasted Customer Attachments for the Project

Customer Additions	2023	2024	2025	2026	2027	2028	2029	2030	2031	2032	Total Forecasted
Conversions											
Residential Units (Singles, Semis, Towns)	45	40	15	11	8	10	9	10	9	9	166
Residential Cumulative	45	85	100	111	119	129	138	148	157	166	
Commercial/Institutional		5	4	2	1	1					13
Commercial Cumulative		5	9	11	12	13					
Total											179

Question:

- a) Please discuss the method and data Enbridge Gas used to forecast 138 residential and 13 commercial and industrial attachments in the Mohawks of the Bay of Quinte and 28 residential customers in the community of Shannonville.
- b) Following the same format in Table 2 above please create a table showing the separately forecasted customer attachments for the Mohawks of the Bay of Quinte and for Shannonville.
- c) Please discuss the basis for the forecast 45 residential customer attachments in 2023 and 40 residential and 5 commercial/industrial customer attachments in 2024.

- d) Discuss any anticipated potential delays that may affect construction schedule for the Project or achieving the forecast number of customer attachments in the first and second year.
- e) Please discuss the 65% capture rate and explain the methodology to determine this rate. Describe the methods and information used to determine the 65% capture rate.
- f) How many customer connections would be possible if the capture rate were 100% and all the residential and commercial/institutional customers in the Project location would be connected?
- g) Please describe in detail Enbridge Gas's outreach activities, plans and/or programs to ensure that the customer attachments will be realized as forecasted.
- h) Please comment on differences in forecasted number of customer attachments Enbridge Gas provided in project proposal approved for funding in Phase 2 of the NGEF process and the project subject to this application?

Response

- a) Municipal Property Assessment Corporation ("MPAC") data was used to establish the basis for the original attachment forecast and to designate property types as residential, commercial or industrial. Field visits were subsequently conducted to confirm addresses within the proposed Project scope and verify the validity of desktop category assumptions, where applicable.
- b) See Table 1 for the forecasted customer attachments for the Mohawks of the Bay of Quinte and Shannonville, respectively.

Table 1: Forecasted Customer Attachments for MBQ and Shannonville

Customer Additions	2023	2024	2025	2026	2027	2028	2029	2030	2031	2032	Total Forecasted
Shannonville (Tyendinaga Township)											
Residential Units (Singles, Semis, Towns)	8	7	3	2	1	1	2	1	2	1	28
Residential Cumulative	8	15	18	20	21	22	24	25	27	28	
MBQ											
Residential Units (Singles, Semis, Towns)	37	33	12	9	7	9	7	9	7	8	138
Residential Cumulative	37	70	82	91	98	107	114	123	130	138	
Commercial/Institutional		4	4	2	1	1					12
Commercial Cumulative		4	8	10	11	12					
Industrial		1									1
Industrial Cumulative		1									
Total	45	45	19	13	9	11	9	10	9	9	179

- c) Residential attachment rates assume approximately 20% in the first year, 15% in the second, and lower increments as we progress through the 10-year forecast. From past experience on community expansion projects, Enbridge Gas has observed that higher attachment values are achieved in the first few years when a project team is actively working in the community. Similarly, in the Company's experience, Commercial/Institutional/Industrial attachments can require a lengthier attachment process as special design considerations are required for such customers. For these reasons, the Company typically forecasts such customers to attach in the second year of the project or later, to account for such custom works.
- d) Potential delays that may affect the construction schedule for the Project include: (i) the timing of when the OEB grants leave to construct the Project, and (ii) timing of when all other applicable permits and approvals are received. At this time, the Company does not anticipate any delays to the construction schedule and does not have any reason to expect that the actual number of customer attachments will be below forecast in the first and second year.
- e) Prior to the amalgamation of Enbridge Gas Distribution Inc. ("EGD") and Union Gas Limited ("Union"), Union assumed a 53% average attachment/penetration rate unless otherwise available through Market Research. By contrast, EGD assumed a 74% average attachment/penetration rate. The simple average of these assumptions was 65%.

In 2017-2018, market research conducted by Forum Research on behalf of Union across its entire franchise area indicated an overall average interest in converting to natural gas of 65%. Further, market research conducted by LURA Consulting on behalf of EGD across its entire franchise area in 2017 indicated an overall average interest in converting of 71.1%.

Finally, in 2020, updated market research conducted by Forum Research on behalf of Enbridge Gas across 12 project areas (primarily former Union franchise areas) yielded an average of 67% "likely to convert to natural gas".

Based on the insights discussed above, for the purposes of filing NGEP project applications, the Company assumed a 65% attachment rate was achievable. To support its conclusions in this regard the Company also completed the Mohawks of the Bay of Quinte & Township of Tyendinaga Natural Gas Questionnaire and an Expressions of Interest campaign in 2022 that reflected an interest rate of over 60%.¹

¹ Exhibit I.STAFF.1 part d), footnote 5

- f) If the capture rate were 100% and all the residential and commercial/institutional customers in the Project area were to connect there would be 273 possible connections (255 residential and 18 commercial/institutional/industrial).
- g) Please see the response to Exhibit I.STAFF.1 part d), for kiosk information and attachment outreach. Enbridge Gas' Customer Attachment team began monthly community outreach on January 24, 2023, and will continue to do so throughout the project life cycle in the form of individual one-on-one conversations at resident's homes either as requested or by means of door-to-door ("D2D") activities. This allows customers the opportunity to ask their personalized questions unique to their circumstances. Customers can share their energy consumption from previous years to obtain costs comparisons and potential savings by assuming equivalent consumption had they been on natural gas.

Enbridge Gas expects to conduct additional customer attachment events/sessions throughout Project construction and execution in coordination with MBQ Chief and council.

- h) As discussed in the response to part a) above, the Company's original Project proposal (EB-2019-0255) was developed based on a table-top estimate and desktop information available at the time; customer count information relied solely upon MPAC data and municipal/community address extracts to establish the basis for the forecast and to designate property types (e.g., residential, commercial or industrial).

Following funding approval, development of the Project progressed including field visits to confirm addresses, refine the total potential customer count and Project scope, and to verify desktop category assumptions, where applicable. As a result of such Project development, the Company identified new builds and gathered more accurate data relative to the MPAC information that supported its original proposal. As a result, 53 additional potential customers were identified.

ENBRIDGE GAS INC.

Answer to Interrogatory from
OEB Staff (“STAFF”)

INTERROGATORY

Reference:

Exhibit E, Tab 1, Schedule 1, page 1 of 5, paragraphs 1-3; Table 1: Estimated Project Costs (\$CAD)

The total estimated Project cost is \$10.7 million. The total pipeline costs are \$8.9 million. The total ancillary costs of \$1.8 million comprises station upgrades related costs. The itemized costs for the Project are presented in the table below.

Table 1: Estimated Project Costs (\$CAD)

Item No.	Description	Pipeline Costs	Ancillary Costs ¹
1.0	Material	123,571	30,100
2.0	Labour and Construction	6,646,356	1,510,423
3.0	Outside Services	1,161,990	17,300
4.0	Land, Permits, Approvals and Consultations	21,403	
5.0	Contingency	801,919	164,266
4.0	Sub-Total	8,755,239	1,722,090
6.0	Interest During Construction	88,329	4,943
7.0	Direct Overheads	65,862	79,032
8.0	Total Project Costs	8,909,430	1,806,065

The estimated costs presented in this application are \$1.5 million higher than the original project proposal presented to the Government of Ontario (2019/2020) for funding under Phase 2 of the NGEF (EB-2019-0255). Enbridge Gas noted that the \$1.5 million cost increase is “...attributed primarily to the completion of the project design and schedule”.

Question:

- a) Please explain how the completion of the project design and economics resulted in the \$1.5 million increase in estimated cost compared to the original estimates in 2019/2020.
- b) Is any portion of the increased cost associated with the increased number of forecasted customer attachments compared to project proposal in 2019/2020? Please discuss.

Response

a) and b)

While preparing a response to this interrogatory, Enbridge Gas noted an error at Exhibit E, Tab 1, Schedule 1, page 1, Table 1. Some contractor labour costs were incorrectly allocated to Direct Overheads; these have been corrected in Table 1 below, by reallocating to the Labour and Construction line item. This correction does not impact the overall Project cost nor the associated DCF analysis.

The cost estimate for the Project differs from the amount estimated in the Company's original proposal (EB-2019-0255) by approximately \$1.5 M.

Table 1: Project Costs vs EB-2019-0255 Proposal

Item No	Description	Table 1 Project Costs (\$CAD)			Project Proposal (EB-2019-0255) (\$CAD)		
		Pipeline	Ancillary	Total	Pipeline	Ancillary	Total
1.0	Material	123,571	30,100	153,671	148,386	5,631	154,017
2.0	Labour and Construction	6,646,356	1,578,430	8,224,786	5,813,995	930,251	6,744,246
3.0	Outside Services	1,161,990	17,300	1,179,290	646,195	9,530	655,726
4.0	Lands, Permits, Approvals and Consultations	21,403		21,403	58,233		58,233
5.0	Contingency	801,919	164,266	966,185	1,314,907	23,166	1,338,073
6.0	SUB TOTAL	8,755,239	1,790,097	10,545,335	7,981,715	968,579	8,950,294
7.0	Interest During Construction	88,329	4,943	93,272	80,415	4,098	84,513
8.0	Direct Overheads	65,862	11,025	144,895	113,400	40,471	153,871
9.0	Total Project Costs	8,909,430	1,806,065	10,715,494	8,175,530	1,013,147	9,188,678

The original NGEF Project proposal included a cost estimate based on high level desktop information available at the time.¹ Upon receipt of Project-specific approval for NGEF funding, the Company set out to refine the Project scope and associated estimate by conducting site specific investigations including site visits, field surveys, environmental studies, and consultation efforts with permitting agencies. The sources of significant variances identified are described in greater detail below:

¹ The original NGEF Project proposal can be found at Attachment 1 to this response.

Station Design –

Upon consulting on station design parameters, it was discovered that the existing station footprint would not accommodate the entire station rebuild and therefore, some additional environmental work and further land acquisition would be required.

Customer Attachments –

Confirmation of the customer count revealed a higher total potential of residents within the Project scope in comparison to the original proposal. As a result, the total forecasted customer attachments increased from 126 to 179. As such, some of the variance is attributed to contractor costs and material costs over the 10 year forecast associated with additional services for 53 customers.

Geotechnical Assessment –

After completing test digs along the pipeline route, significant rock was discovered in the Project area, which has increased the cost of the construction estimate for both mains and services.

Schedule 5E
Enbridge Gas Community Expansion Project Proposal

Mohawks of the Bay of Quinte FN

**Enbridge Gas Inc.
Potential Projects to Expand Access to Natural Gas Distribution**

Part I – Name of Proponent	
Name of Proponent: Enbridge Gas Inc.	File No: EB-2019-0255
Project Name: Mohawks of the Bay of Quinte FN Community Expansion Project	
Address of Head Office: 50 Keil Drive North Chatham, ON N7M 5M1	Telephone Number: 519-436-4600
Name of Individual to Contact: Patrick McMahon	Office Telephone Number: 519-436-5325
	Cell Phone Number: 519-437-0759
	Email Address: patrick.mcmahon@enbridge.com

Part II – Description of Proponent’s Technical Expertise and Financial Capability
<i>Natural gas distributors that are currently rate-regulated by the OEB are not required to complete this Part.</i>
<i>A proponent that is not currently rate-regulated as a natural gas distributor by the OEB and that has multiple proposed projects is only required to provide the information in this Part once, unless the proponent has different organizational or financial structure approaches for its projects. In that case, the information in this Part must be provided for each different organizational or financing structure.</i>

Part II – Description of Proponent’s Technical Expertise and Financial Capability	
2.1	<p>Describe the proponent’s technical expertise to develop, construct, operate and maintain a natural gas distribution system.</p> <p>N/A</p>
2.2	<p>Describe the proponent’s financial capability to develop, construct, operate and maintain a natural gas distribution system, and provide the following:</p> <ul style="list-style-type: none"> • Current credit rating of the proponent, its parent or associated companies. • Financial statements for each of the past two fiscal years. This may include audited financial statements, annual reports, prospectuses or other such information. If the proponent does not have financial statements (because it is a new entrant), the proponent is instead to provide pro forma financial statements for two years along with notes or business plans explaining the assumptions used in preparing the pro forma statements, where the documents must be signed by at least one key individual. • If the proponent needs to raise additional debt or equity to finance the proposed project, evidence of the proponent’s ability to access the debt and equity markets. <p>New entrants that cannot provide the information identified in this section should explain why that is the case and provide the best information that they have available.</p> <p>N/A</p>

Part III – Description of and Support for Project

3.1

Provide a general overview of the project, which is to include the following: communities to be connected, including whether the project would serve any on-reserve Indigenous communities; existing population of each community by residential, commercial/institutional and industrial sectors; routing; length of pipeline; and nominal pipe size.

Enbridge Gas is proposing to provide gas distribution service to the Mohawks of the Bay of Quinte First Nation residing on the Tyendinaga Mohawk Territory as well as parts of the community of Shannonville within the Tyendinaga Mohawk Territory. The proposed facilities will provide access to natural gas to a forecasted 126 customers (124 residential and 2 commercial / institutional).

The proposed project will tie-in to an existing 4” polyethylene pipeline near the intersection of Wyman Road and York Road in the Tyendinaga Mohawk Territory. The proposed pipeline runs west along Lower Slash Road from the intersection with Homeland Drive to Wyman Road then south to the intersection of Wyman Road and York Road. The pipeline will then run southwest along Ridge Road to the intersection of Ridge Road and Norways Road. The proposed facilities also include a pipeline that runs northwest along York Road to Young Street, Atsia Court, Queen Street, Beach Road and Gore Street within Shannonville.

A station rebuild is required to accommodate additional customers onto the distribution system.

The approximate length and size of the distribution piping required:

Pipe Type	Diameter (NPS)	Length (m)
Polyethylene	2	17,300
Polyethylene	4	2,800

Please refer to Schedule 5E-1 for Project Map.

3.2

Provide the annual and cumulative forecast of the number of customer attachments over the ten-year rate stability period by residential, commercial/institutional and industrial sectors for each community. Indicate for each customer type whether the service to be provided would be firm or interruptible.

Please refer to Schedule 5E-2, Table 3.2.

<p>3.3</p>	<p>Provide the annual and cumulative forecast of volumes (in m³) over the ten-year rate stability period by residential, commercial/institutional and industrial sectors for each community.</p> <p>For the residential segment, the default value for the average consumption level is 2,200 m³ per year. A proponent that has more accurate information regarding the annual consumption for residential customers in a given community may use that value, in which case it must explain how it has determined that it is more accurate than the default.</p> <p>Please refer to Schedule 5E-2, Table 3.3.</p>
<p>3.4</p>	<p>Provide the estimated conversion costs to convert each of the existing heating systems (e.g., propane forced air, oil forced air, electric forced air and electric baseboard) and water-heating systems (e.g., electric, oil and propane) to natural gas. To the extent available, provide information on the current proportion of customers on each type of heating system.</p> <p>Provide the estimated annual costs of the existing alternative fuels relative to natural gas, including the annual savings with natural gas. The calculation of household energy costs for natural gas should include conversion costs, commodity costs, associated upstream transportation costs to Ontario, incremental CNG and LNG costs (where applicable), costs under the federal <i>Greenhouse Gas Pollution Pricing Act</i> and distribution costs. The assessment of household energy cost impacts should include greenhouse gas (GHG) emission estimates (whether positive or negative) related to converting existing heating and water heating systems to natural gas. The major assumptions (e.g., conversion factors) used in the calculations must also be provided.</p> <p>Please refer to Schedule 5E-3, Table 3.4.</p>
<p>3.5</p>	<p>Provide the proposed schedule for construction including the start date, all major milestones (with any phases) and the projected in-service date.</p> <p>Please refer to Schedule 5E-4 for Proposed Construction Schedule.</p>
<p>3.6</p>	<p>Provide letter(s) from the Band Council(s) and/or local government, as applicable, stating support for the project, including details of any commitment to financial support.</p> <p>Please refer to Schedule 5E-5.</p>

3.7	<p>Provide a copy of the Certificate of Public Convenience and Necessity (Certificate) for the area to be served, if held by the project proponent. If not, indicate whether another entity holds the Certificate for the area to be served, if known, and if so, identify the Certificate holder.</p> <p>Where the project proponent holds a Certificate for the areas to be served, specify the boundaries of the Certificate and indicate whether the boundaries encompass the entire area that would be supplied by the proposed project.</p> <p>Please refer to Schedule 5E-6 for Enbridge’s CPCN for the Township of Tyendinaga (FBC 217) and Enbridge’s permit issued under Section 28 of the <i>Indian Act</i> related to the Tyendinaga Mohawk Territory.</p>
<p>Part IV – Cost of Project</p>	
4.1	<p>Confirm that the proposed project includes a ten-year rate stability period.</p> <p>The proposed project does include a ten-year rate stability period.</p>
4.2	<p>Provide the total forecast of capital costs (including any forecast of upstream reinforcement costs) of the project at the end of the rate stability period (i.e., year ten).</p> <p>Where applicable, the inflation rate to be used is the most recent quarter average GDP IPI FDD. For interest during construction, the proponent is to use the OEB-prescribed interest rate for construction work in progress (CWIP).</p> <p>For projects proposing to use CNG and/or LNG, the costs of required infrastructure and other associated costs must be included as part of the total project capital costs.</p> <p>Include any upstream reinforcement costs in the total cost of the project. To the extent that the reinforcement costs for an incumbent utility’s proposed project are materially different from the reinforcement costs that the utility has estimated for another proponent’s project in the same area, the incumbent utility must identify in its filing that two separate estimates exist and explain the reasons for the differences.</p> <p>Please refer to Schedule 5E-2, Table 4.2.</p>

4.3	<p>Provide the total annual forecast revenue requirement of the project over the ten-year rate stability period (using fully allocated OM&A costs) and rate base amount at the end of year ten.</p> <p>Complete the tables below:</p> <p>Revenue Requirement</p> <table border="1" style="margin-left: 40px; margin-bottom: 20px;"> <thead> <tr> <th style="text-align: left;">Description</th> <th style="text-align: center;">Year 1</th> <th style="text-align: center;">Year 2...</th> <th style="text-align: center;">Year 10</th> <th style="text-align: center;">Total</th> </tr> </thead> <tbody> <tr> <td>Revenue Requirement</td> <td></td> <td></td> <td></td> <td></td> </tr> </tbody> </table> <table border="1" style="margin-left: 40px;"> <thead> <tr> <th style="text-align: left;">Description</th> <th style="text-align: center;">Year 10</th> </tr> </thead> <tbody> <tr> <td>Closing Rate Base</td> <td></td> </tr> </tbody> </table> <p>Where applicable, the inflation rate to be used is the most recent quarter average GDP IPI FDD. For interest during construction, the proponent is to use the OEB-prescribed interest rate for construction work in progress (CWIP).</p> <p>Please refer to Schedule 5E-2, Table 4.3.</p>	Description	Year 1	Year 2...	Year 10	Total	Revenue Requirement					Description	Year 10	Closing Rate Base	
Description	Year 1	Year 2...	Year 10	Total											
Revenue Requirement															
Description	Year 10														
Closing Rate Base															

Part V – Section 36.2 Funding	
5.1	<p>Provide the total amount of section 36.2 funding needed to support the project.</p> <p>\$8,080,907</p> <p>Please refer to Schedule 5E-2, Table 5.1.</p>
5.2	<p>Provide the section 36.2 funding amount per customer number served in year ten of the project.</p> <p>\$64,134</p> <p>Please refer to Schedule 5E-2, Table 5.2.</p>
5.3	<p>Provide the section 36.2 funding amount per volume (m³) in year ten of the project.</p> <p>\$29.50</p> <p>Please refer to Schedule 5E-2, Table 5.3.</p>

Part VI – Distribution Charge	
6.1	<p>Provide the estimated amount that the proponent proposes to recover from residential customers on an annual basis (inclusive of any system expansion surcharge) in the form of an estimated annual distribution charge inclusive of fixed and variable charges over the rate stability period.</p> <p>Provide a confirmation that there would be no material cross-subsidization between rate classes.</p> <p>Please refer to Schedule 5E-2, Table 6.1.</p> <p>Enbridge Gas confirms that there will be no material cross-subsidization between rate classes.</p>

Part VII – Profitability Index / Benefit to Cost Ratio	
7.1	<p>Provide, in a summary table, the expected Profitability Index (PI) of the project, inclusive of the proposed section 36.2 funding. Provide any major assumptions used in the calculation, and specify all proposed section 36.2 funding, revenue from rates (including any proposed system expansion surcharges), capital contributions and municipal tax holidays or other municipal financial support.</p> <p>The project must have a PI of 1.0. The PI is to be calculated based on an individual project (i.e., not a “portfolio” of projects).</p> <p>Please refer to Schedule 5E-2, Table 7.1.</p>
7.2	<p>Provide, in a summary table that otherwise meets the requirements of section 7.1, the expected PI of the project without the proposed section 36.2 funding.</p> <p>Please refer to Schedule 5E-2, Table 7.2.</p>

Part VIII – OEB Approvals	
8.1	<p>Identify any OEB approvals that will be required for the project (Leave to Construct, Certificate of Public Convenience and Necessity, Municipal Franchise Agreement, Rate Order).</p> <ul style="list-style-type: none">• Leave to Construct• System Expansion Surcharge (SES) rate approval (subject to OEB determinations in the EB-2020-0094 harmonization proceeding)
8.2	<p>For OEB approvals identified in section 8.1, provide a schedule for applying for them and the date by which each of these approvals is required to meet the proposed in-service date. For this purpose, proponents should reference the performance standards posted on the OEB’s website and where applicable assume a written hearing process.</p> <p>Please refer to Schedule 5E-4.</p>

Schedule 5E-1
Enbridge Gas Community Expansion Project Proposal

Mohawks of the Bay of Quinte FN

Mohawks of the Bay of Quinte

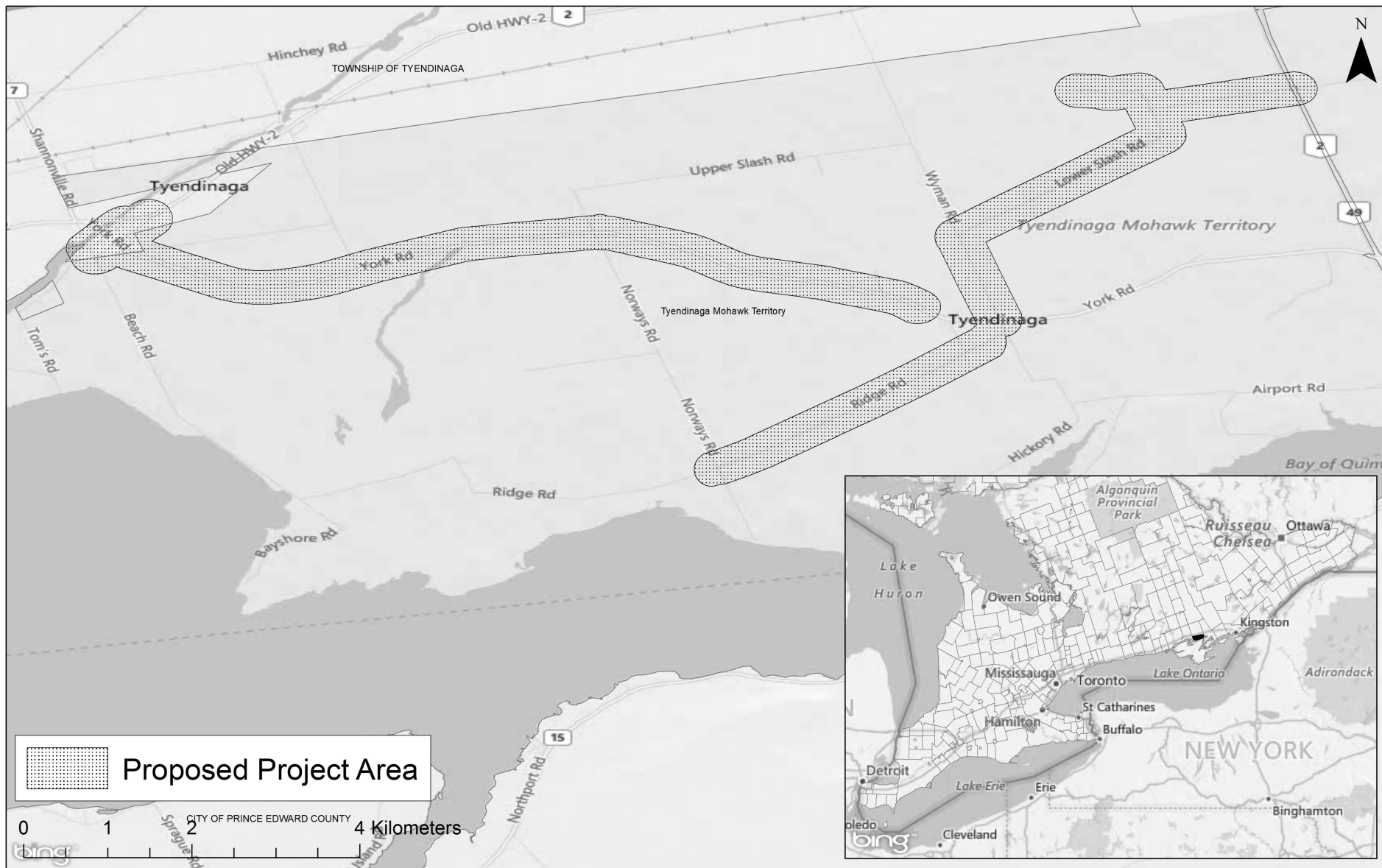

Schedule 5E-2
Enbridge Gas Community Expansion Project Proposal

Mohawks of the Bay of Quinte FN

Community Expansion **Mohawks of the Bay of Quinte FN**
InService Date: Nov-01-2023

EB-2019-0255
 Schedule 5E-2

Table 3.2 - Customer Attachments Over The Rate Stability Period

<u>Customer Type</u>	<u>Firm / IT</u>	<u>Project Year</u>	<u>1</u>	<u>2</u>	<u>3</u>	<u>4</u>	<u>5</u>	<u>6</u>	<u>7</u>	<u>8</u>	<u>9</u>	<u>10</u>	<u>Total</u>
Residential	Firm		38	30	18	10	10	4	4	4	3	3	124
Commercial	Firm		-	2	-	-	-	-	-	-	-	-	2
Institutional	Firm		-	-	-	-	-	-	-	-	-	-	-
Agricultural	Firm		-	-	-	-	-	-	-	-	-	-	-
Industrial	Firm		-	-	-	-	-	-	-	-	-	-	-
Total Customers			<u>38</u>	<u>32</u>	<u>18</u>	<u>10</u>	<u>10</u>	<u>4</u>	<u>4</u>	<u>4</u>	<u>3</u>	<u>3</u>	<u>126</u>
Cumulative Customers			38	70	88	98	108	112	116	120	123	126	

Table 3.3 - Annual and Cumulative Volumes Over The Rate Stability Period (m3)

<u>Customer Type</u>	<u>Project Year</u>	<u>1</u>	<u>2</u>	<u>3</u>	<u>4</u>	<u>Annual Volumes - m3</u>					<u>Total</u>	
						<u>5</u>	<u>6</u>	<u>7</u>	<u>8</u>	<u>9</u>		<u>10</u>
Residential		41,800	116,600	169,400	200,200	222,200	237,600	246,400	255,200	262,900	269,500	2,021,800
Commercial		-	2,200	4,400	4,400	4,400	4,400	4,400	4,400	4,400	4,400	37,400
Institutional		-	-	-	-	-	-	-	-	-	-	-
Agricultural		-	-	-	-	-	-	-	-	-	-	-
Industrial		-	-	-	-	-	-	-	-	-	-	-
Total Volumes		<u>41,800</u>	<u>118,800</u>	<u>173,800</u>	<u>204,600</u>	<u>226,600</u>	<u>242,000</u>	<u>250,800</u>	<u>259,600</u>	<u>267,300</u>	<u>273,900</u>	<u>2,059,200</u>

<u>Customer Type</u>	<u>Project Year</u>	<u>1</u>	<u>2</u>	<u>3</u>	<u>4</u>	<u>Cumulative Volumes - m3</u>					<u>10</u>
						<u>5</u>	<u>6</u>	<u>7</u>	<u>8</u>	<u>9</u>	
Residential		41,800	158,400	327,800	528,000	750,200	987,800	1,234,200	1,489,400	1,752,300	2,021,800
Commercial		-	2,200	6,600	11,000	15,400	19,800	24,200	28,600	33,000	37,400
Institutional		-	-	-	-	-	-	-	-	-	-
Agricultural		-	-	-	-	-	-	-	-	-	-
Industrial		-	-	-	-	-	-	-	-	-	-
Total Volumes		<u>41,800</u>	<u>160,600</u>	<u>334,400</u>	<u>539,000</u>	<u>765,600</u>	<u>1,007,600</u>	<u>1,258,400</u>	<u>1,518,000</u>	<u>1,785,300</u>	<u>2,059,200</u>

Table 4.2 - Total Capital Costs At End Of The Rate Stability Period

Total Capital Costs	<u>Year 10</u> <u>\$ 9,188,678</u>
---------------------	---------------------------------------

Table 4.3 - Revenue Requirement Over The Rate Stability Period

	<u>Project Year</u>	<u>1</u>	<u>2</u>	<u>3</u>	<u>4</u>	<u>5</u>	<u>6</u>	<u>7</u>	<u>8</u>	<u>9</u>	<u>10</u>	<u>Total</u>
Revenue Requirement		<u>\$ 29,262</u>	<u>76,723</u>	<u>95,803</u>	<u>106,221</u>	<u>113,152</u>	<u>118,578</u>	<u>120,936</u>	<u>123,265</u>	<u>125,164</u>	<u>126,653</u>	<u>\$ 1,035,758</u>

Closing Rate Base (net of proposed Section 36.2 funding)	<u>Year 10</u> <u>\$ 891,070</u>
--	-------------------------------------

Community Expansion **Mohawks of the Bay of Quinte FN**
InService Date: Nov-01-2023

EB-2019-0255
 Schedule 5E-2

Table 5.1 - Total Amount of Section 36.2 Funding

Section 36.2 Funding Needed to Support the Project \$ 8,080,907

Table 5.2 - Section 36.2 Funding Amount Per Customer Served

Section 36.2 Funding Amount Per Customer Served \$ Year 10
 64,134

Table 5.3 - Section 36.2 Funding Amount Per Volume (m3)

Section 36.2 Funding Amount Per Year 10 Volume (m3) \$ Year 10
 29.50

Table 6.1 - Distribution Charge

	<u>Project Year</u>	<u>1</u>	<u>2</u>	<u>3</u>	<u>4</u>	<u>5</u>	<u>6</u>	<u>7</u>	<u>8</u>	<u>9</u>	<u>10</u>	<u>Total</u>
Distribution Revenue	\$	8,803	25,020	36,603	43,089	47,723	50,966	52,819	54,672	56,294	57,684	\$ 433,673
SES Revenue		9,614	27,324	39,974	47,058	52,118	55,660	57,684	59,708	61,479	62,997	473,616
Total Distribution Charge	\$	<u>18,417</u>	<u>52,344</u>	<u>76,577</u>	<u>90,147</u>	<u>99,841</u>	<u>106,626</u>	<u>110,503</u>	<u>114,380</u>	<u>117,773</u>	<u>120,681</u>	<u>\$ 907,289</u>

Table 7.1 - Profitability Index (PI) Inclusive of Section 36.2 Funding

	<u>Net Present Value</u>
<u>Cash Inflow</u>	
Revenue:	
Distribution Revenue	\$ 922,213
System Expansion Surcharge (SES) Revenue	1,007,154
Total Revenue (A)	<u>1,929,367</u>
Expenses:	
O&M Expense	(282,302)
Municipal Tax	(493,795)
Income Tax	(140,854)
Total Expenses (B)	<u>(916,951)</u>
Total Cash Inflow (C = A + B)	\$ 1,012,416
<u>Cash Outflow</u>	
Gross Capital	(9,092,533)
Proposed Section 36.2 Funding	8,080,907
Change in Working Capital	(790)
Total Cash Outflow (D)	<u>\$ (1,012,416)</u>
Profitability Index (PI) Inclusive of Section 36.2 Funding (C / D)	<u>1.00</u>

Community Expansion **Mohawks of the Bay of Quinte FN**
InService Date: Nov-01-2023

EB-2019-0255
 Schedule 5E-2

Table 7.2 - Profitability Index (PI) Without Section 36.2 Funding

	<u>Net Present Value</u>
<u>Cash Inflow</u>	
Revenue:	
Distribution Revenue	\$ 922,213
System Expansion Surcharge (SES) Revenue	<u>1,007,154</u>
Total Revenue (A)	1,929,367
Expenses:	
O&M Expense	(282,302)
Municipal Tax	(493,795)
Income Tax	<u>1,107,025</u>
Total Expenses (B)	330,928
Total Cash Inflow (C = A + B)	\$ 2,260,295
<u>Cash Outflow</u>	
Gross Capital	(9,092,533)
Change in Working Capital	<u>(790)</u>
Total Cash Outflow (D)	<u>\$ (9,093,323)</u>
Profitability Index (PI) Without Section 36.2 Funding (C / D)	<u>0.25</u>

Schedule 5E-3
Enbridge Gas Community Expansion Project Proposal

Mohawks of the Bay of Quinte FN

Section 3.4 Mohawks of the Bay of Quinte FN

Total Forecasted Customers 126 **Penetration Rate** 67%

Existing Fuel / Heating Type	Number of Customers	Current proportion of customer ¹	Estimated Conversion Cost ²	Estimated Annual Energy Costs (existing fuel)	Estimated Annual Energy Costs (natural gas)	Estimated Annual Savings per customer	Estimated Annual Savings	Estimated Annual GHG per customer Existing Fuel (tCO2e)	Estimated Annual GHG Change (increased GHG is +ve/decreased GHG is -ve) per customer switching to natural gas (tCO2e)	Estimated Annual GHG - Total Community - Existing Fuel (tCO2e)	Estimated Annual GHG Change (increased GHG is +ve/decreased GHG is -ve) total community switching to natural gas (tCO2e)
Oil	26	21%	\$ 5,000	\$ 2,787	\$ 1,495	\$ 1,292	\$ 34,189	6.6	-2.4	173	(64)
Electricity F/A	11	9%	\$ 5,000	\$ 1,673	\$ 1,495	\$ 178	\$ 2,013	0.5	3.6	6	41
Electricity Baseboard	15	12%	\$ 12,000	\$ 1,673	\$ 1,495	\$ 178	\$ 2,684	0.5	3.6	8	54
Propane	55	44%	\$ 600	\$ 1,611	\$ 1,495	\$ 116	\$ 6,446	5.1	-1.0	283	(54)
Wood	11	9%	\$ 3,500	N/A	N/A	\$ -	N/A	NA	NA	NA	NA
Other	6	5%	\$ 5,000	N/A	N/A	\$ -	N/A				
Total	126	100%	\$ 31,100	\$ 7,744	\$ 5,981	\$ 1,763	\$ 45,332	12.7	3.8	471	(24)

¹ Fuel shares were estimated based on the average fuel share distribution observed in other potential expansion areas. Specifically, the fuel share distribution from 27 prospective expansion areas surveyed in 2018 and 2020 were averaged, with weights based number of homes in each area. Fuel percentages may not add up to 100% due to rounding error.

² Based on Market Research gathered information. All of the costs are installed costs, so the cost of new equipment + the cost of having it installed.

	Emission Factors				Units
	CO2	CH4	N2O	CO2e	
Natural Gas	1863 g/m3	0.037 g/m3	0.035 g/m3	0.001874355 tonnes/m3	
Heating Oil	2725 g/L	0.006 g/L	0.031 g/L	0.002734388 tonnes/L	
Propane	1510 g/L	0.024 g/L	0.108 g/L	0.001542784 tonnes/L	
Electricity	30 g/kWh	-	-	0.00003 tonnes/kWh	
Wood	-	-	-	-	

Emission Factor Sources:

Natural gas, heating oil and propane CO2 factors: Guideline for Quantification, Reporting and Verification of GHG Emissions - Ontario Ministry of Environment, Conservation and Parks

Natural gas, heating oil and propane CH4 and N2O factors: Canada's Greenhouse Gas Quantification Requirements, December 2019 - Environment and Climate Change Canada

Electricity factors: 2020 National Inventory Report (Part 3) - Environment and Climate Change Canada (using 2018 consumption intensity for Ontario)

Estimated Annual GHG (tCO2e) = Emission Factors x Consumption Equivalent

Estimated Annual GHG Change (tCO2e) = Estimated Annual GHG For Natural Gas - Estimated Annual GHG For Existing Fuel (tCO2e)

Rate 01 (Community Expansion, FN)				
Consumption Equivalent			Price per Unit	
Gas	m3	2200	Gas (incl. fixed)	\$/m3 0.680
Heating oil	L	2397	Heating oil	\$/L 1.163
Electricity	kWh	17778	Electricity	\$/kWh 0.094
Propane	L	3309	Propane	\$/L 0.487

Notes:

Gas prices correspond to EGI (Union Gas North East) April 2020 rates, including 23 cents per m³ SES charge.

Heating Oil Prices correspond to the latest available Toronto retail prices (February 2019)

Electricity prices correspond to Hydro One (Med Density - R1) distribution rates implemented January 1, 2020 and includes the new Ontario Electricity Rebate (OER).

The calculated annual savings vs electricity do not reflect the COVID-19 Emergency pricing which is effective for 45 days.

Qualified First Nations (FN) rates excludes distribution charges per First Nations Delivery Credit.

Propane prices correspond to the latest available monthly average EDPRO residential rates for Zone 4 (March 2020).

Carbon price is included for all energy types as reported. All costs exclude HST.

Schedule 5E-4
Enbridge Gas Community Expansion Project Proposal

Mohawks of the Bay of Quinte FN

Schedule 5E-5
Enbridge Gas Community Expansion Project Proposal

Mohawks of the Bay of Quinte FN



MOHAWKS OF THE BAY OF QUINTE

KENHTEKE KANYEN'KEHÁ:KA

OFFICE OF THE CHIEF

24 Meadow Drive, Tyendinaga Mohawk Territory, ON K0K 1X0
Phone 613-396-3424 Fax 613-396-3627

May 15, 2020

Luke Skaarup
Director, Northern Region Operations
Enbridge Gas Inc.
500 Consumers Rd,
Toronto, ON M2J 1P8

**Re: Expression of Support for Natural Gas Expansion
Mohawks of the Bay of Quinte Natural Gas Servicing Project**

In December 2019, the Government of Ontario announced plans to further increase access to natural gas by making financial support available for new service expansion projects. This Natural Gas Expansion Program will unlock financial support needed to expand natural gas service to new areas across Ontario that are not economically feasible without support. Our First Nation is one such area, and we are eager to bring this affordable, reliable fuel source to our residents and businesses.

The Mohawks of the Bay of Quinte (MBQ) is a First Nation residing on the Tyendinaga Mohawk Territory in eastern Ontario along the northern shores of the Bay of Quinte, south of Highway # 401, centrally located between Belleville and Kingston, Ontario. The Tyendinaga Mohawk Territory encompasses 7,275 hectares of land with approximately 20 km of shoreline along the banks of the Bay of Quinte. There are approximately 85km of roads comprised of gravel, surface treated and paved road. In addition, approximately 1300 homes both private and MBQ owned rental properties providing permanent, interim and seasonal residency.

As of December 2019, the MBQ is considered the fourth largest First Nation Community in Ontario Region by total membership. Similarly, MBQ had the tenth largest membership of all First Nations in Canada.

The MBQ is a growing dynamic First Nation with an award-winning housing program and expanding economic development opportunities. We are working towards ensuring our members have access to a diversified energy model that includes natural gas servicing. The proposed service areas will not only address residential needs but will provide a foundation that will attract and promote business investment and development.

Factors to consider:

- the MBQ Community Energy Plan dated December 2017 estimated that 47% of the homes in the community are utilizing electric heat as a fuel source contributing to significantly higher home heating costs. MBQ residents have higher energy costs on the Territory because we are levied the rural rate by Hydro One.
- Existing high-pressure transmission lines traverse our traditional Territory to service the Town of Deseronto and the Town of Picton; however, MBQ has limited access to natural

gas servicing.

- MBQ supported and worked in collaboration with Union Gas for the relocation of the high pressure main from the Skyway Bridge and the directional bore to install the high transmission gas main under the Bay of Quinte.

In compliance with the draft Guidelines issued by the OEB (EB-2019-0255), we are aware that Enbridge Gas Inc. may be required to include support for the proposed project from Band Council(s) and/or local government, as applicable, demonstrated through a written expression of support and/or a commitment to financial support in its project submissions. Therefore, the Mohawks of the Bay of Quinte are formally expressing our interest to have the Mohawks of the Bay of Quinte Natural Gas Servicing Project included on Enbridge Gas' list of projects being proposed to the Ontario Energy Board (OEB) for consideration for financial support through the Natural Gas Expansion Program.

We are hopeful that, in the spirit of recent improvements in government to government relations and reconciliation with the Province, the Ontario Energy Board will support the MBQ Natural Gas Servicing Project to ensure our residents have access to natural gas servicing in an effort to provide an affordable heating fuel source, reduce our community's carbon footprint and minimize potential adverse environmental impacts from alternative heating sources.

Natural gas is the most common, affordable heating fuel in Ontario. We fully support the efforts of Enbridge Gas Inc., the OEB and the Ministry of Energy, Northern Development and Mines. We look forward to working together to expand natural gas access in our community to attract new opportunities, help create jobs and lower monthly costs for our residents.

Sincerely,

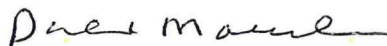

Chief R. Donald Maracle
Mohawks of the Bay of Quinte
rdonm@mbq-tmt.org
613-391-9249

etk/RDM

cc Tyendinaga Mohawk Council
Angela Maracle, A/CAO
Todd Kring, Director of Community Infrastructure



The Corporation of the Township of Tyendinaga
Reeve, Rick Phillips
May 27, 2020

TO: The Mohawks of The Bay of Quinte
RE: Letter of Support- Natural Gas Expansion

Please see the following resolution passed by Township of Tyendinaga Council on May 25th, 2020, supporting your application for the Natural Gas Expansion project being undertaken by the Ontario Energy Board at the request of the Ministry of Energy.

“d) MBQ- Letter of Support for Natural Gas Expansion

MOVED BY: Councillor Kennelly

SECONDED BY: Deputy Reeve Hannafin

THAT Council receives the request from the Mohawks of the Bay of Quinte for support of their application for natural gas expansion.

AND THAT Council directs the CAO to provide the Mohawks of the Bay of Quinte confirmation of the Township of Tyendinaga’s support for their application for natural gas expansion.

CARRIED”

Should you have any questions please feel free to contact our office.
Best Regards,

A handwritten signature in cursive script that reads "Rick Phillips".

Rick Phillips
Reeve-
The Corporation of the Township of Tyendinaga
859 Melrose Road, Shannonville, ON, K0K 3A0
(613) 396-1944

A handwritten signature in cursive script that reads "Brad Roach".

Brad Roach
CAO (Chief Administrative Officer)
Clerk-Treasurer
The Corporation of the Township of Tyendinaga
859 Melrose Road, Shannonville, ON, K0K 3A0
(613) 396-1944 | clerk@tyendinagatownship.com
www.tyendinagatownship.com

Schedule 5E-6
Enbridge Gas Community Expansion Project Proposal

Mohawks of the Bay of Quinte FN

the Applicant to the Board.

DATED at Toronto this 2nd day of May, 1958.

ONTARIO FUEL BOARD



Chairman

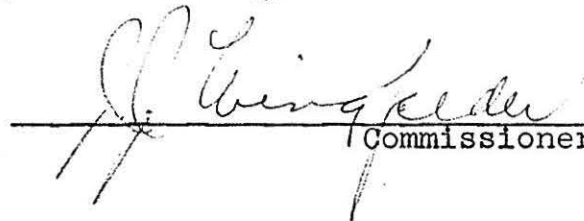

Commissioner

Application for Registration

Privacy Act Statement

"This statement explains the purposes and use of your personal information. Only information needed to respond to program requirements will be requested. Collection and use of personal information is in accordance with the *Privacy Act*. In some cases, information may be disclosed without your consent pursuant to subsection 8(2) of the *Privacy Act*.

The collection and use of your personal information for this Statutory Declaration is authorized by sections 21 - 55 of the *Indian Act* <http://laws-lois.justice.gc.ca/eng/acts/i-5/> and is required for your participation.

We will use your personal information, your contact information, for the processing of the form. We share the personal information you give us with Bands (First Nation Governments) for whom AANDC tracks this. The information collected is described in Personal Information Bank "Monitoring and Compliance of Reserve Land Instruments", AANDC PPU 096, detailed at <http://www.aandc-aandc.gc.ca/eng/1100100011039/1100100011040>, will be retained for a period of 30 years after the last administrative action and then transferred to Library and Archives Canada (LAC) as archival records.

As stated in the *Privacy Act*, you have the right to access your personal information and request changes to incorrect information. Contact our office (toll-free) at 1-800-567-9604 to notify us about incorrect information. For more information on privacy issues and the *Privacy Act* in general, you can consult the Privacy Commissioner at 1 (800) 282-1376.

Please send two copies of this document to your regional Aboriginal Affairs and Northern Development Canada office listed in the 'Contact Us' directory.

<u>Registration Number</u> 6091209	<u>Received Date</u>	<u>Regional File Number</u>
---------------------------------------	----------------------	-----------------------------

NAME OF PARTIES TO INSTRUMENT	
<u>Name</u> Crown Canada	Grantor
<u>Name</u> UNION GAS LIMITED	Grantee

Instrument Type Permit 018
 Instrument Date 2016/02/10
 Purpose GAS PIPELINE
 Remarks

LAND DESCRIPTION	
Province :	ONTARIO
Reserve Name	06217 - TYENDINAGA MOHAWK TERRITORY
Legal Description - Land Affected	

List of Supporting documentation (must be attached to document or a registration number quoted)

Applicant Email : _____ Band Email : _____

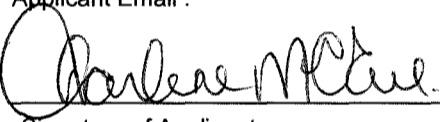
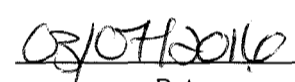
 ⁵¹⁹ 781-2499 _____ 

Signature of Applicant Tel. number of Applicant email Date

Return To :
Charlene McCue 58 Dalhousie St, 3rd Floor P.O. Box 1960 Brantford, ONTARIO N3T 5W5

Registration Number 6091209

Registration Date: March 11, 2016 and Time: 10:27:45am

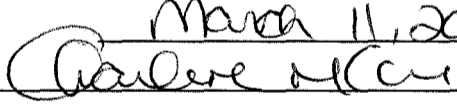
_____  _____ 3/11/2016

Signature of Registration Officer Date

Comments

Reason for return

Signature of Registration Officer Date

**DEPARTMENT OF INDIAN AFFAIRS
& NORTHERN DEVELOPMENT CANADA**

PERMIT

This Agreement made in quadruplicate, as of this 10 day of FEBRUARY, 2016

BETWEEN:

HER MAJESTY THE QUEEN in right of
Canada, ("Her Majesty") as represented by the
Minister of Indian Affairs and Northern
Development Canada,
("Minister")

THE PARTY OF THE FIRST PART

AND:

UNION GAS LIMITED,
A Company incorporated under the laws of the
Province of Ontario having its Head Office at
the Municipality of Chatham-Kent

(the "Permittee")

THE PARTY OF THE SECOND PART

RECITALS:

Whereas the Permittee has applied to the Minister to use and occupy the lands hereinafter described; and

Whereas the lands hereinafter described are part of those lands known as the Tyendinaga Mohawk Territory Reserve No. 38, in the Province of Ontario, which is a Reserve within the meaning of that terms as defined in the Indian Act, R.S.C., 1985, which have been set apart for the use and benefit of the Mohawks of the Bay of Quinte First Nation; and

Whereas the First Nation has requested that Permittee supply gas services to residences and other buildings located and to be located on the said lands; and

Whereas the Permittee has requested the right to lay down, maintain and use pipes and other necessary works for the distribution and transmission of gas on, in or under the said lands; and

Whereas by resolution, the Tyendinaga Mohawk Council has, by Motion Number 2015/16045 dated the 7th day of August 2015 consented to the Permittee's application; and a copy of which is attached hereto as Appendix A;

NOW THEREFORE THIS AGREEMENT WITNESSES that in consideration of the mutual covenants and agreements herein, and subject to the terms and conditions of this agreement, the Minister, on behalf of Her Majesty, under the authority of subsection 28(2) of the *Indian Act* hereby grants to the Permittee the right to use and occupy the lands hereinafter described subject to the terms and conditions of this agreement

DEFINITIONS:

1. In this Permit:
 - (a) "Band" means the Mohawks of the Bay of Quinte Band of Indians or any successor to the Band;
 - (b) "Band Council" means the Tyendinaga Mohawk Council, a council of the band within the meaning of the *Indian Act*;
 - (c) "Canadian Environmental Protection Act" means the *Canadian Environmental Protection Act, 2012*, S.C., 2012, c. 19, s.52 and regulations made under that Act, all as amended, replaced or established from time to time;
 - (d) "Federal Court Act" means the *Federal Court Act*, R.S.C. 1985, c. F-7 and regulations made under that Act, all as amended, replaced or established from time to time;
 - (e) "Her Majesty" means Her Majesty in right of Canada and includes Her heirs and successors;
 - (f) "Improvements" mean all buildings, structures, facilities, mains, pipes, conduits, services, valves, regulators, curb boxes, stations and drips and other equipment and works which are at any time and from time to time situate on or under the Permit Area ;
 - (g) "Indian Act" means the *Indian Act*, R.S.C. 1985, c. I-5, and regulations made under that Act, all as amended, replaced or established from time to time;
 - (h) "Minister" means the Minister of Indian Affairs and Northern Development or any official of the Department of Indian Affairs and Northern Development acting on behalf of the Minister;
 - (i) "Permit Area" means the area described in Article 2 of this Permit;
 - (j) "Permit Period" means the period described in Article 5 of this Permit;
 - (k) "Permittee" means Union Gas Limited; and any officers, employees, agents or contractors acting on behalf of Union Gas Limited.
 - (l) "Reserve" means the Tyendinaga Mohawk Territory, in the Province of Ontario, Tyendinaga Indian Reserve No. 38, as renamed from time to time.

DESCRIPTION

2. The Minister authorizes the Permittee to use and occupy the lands situate, lying, and being part of the Reserve together with appurtenances, save and except any lands surrendered pursuant to Sections 37, 38, 39, 40 and 41 of the Indian Act-

PRIOR ENCUMBRANCES

3. The use and occupation referred to in Article 2 is subject to all prior encumbrances and to all prior grants whether or not the Permittee has notice of same, reserving all mines and minerals solid, liquid, or gaseous which may be found to exist within, upon or under the Permit Area.

PURPOSE

4. The Permittee shall use the Permit Area for the purpose of distribution of natural gas to the residences and other buildings located and to be located on the Reserve and for no other purpose whatsoever.

PERMIT PERIOD

5. This Permit shall be for as long as the Permit Area is required for the distribution of natural gas on the Permit Area for the benefit of the First Nation.

PERMIT FEE

6. Commencing on this day, and in consideration of the rights authorized herein, the Permittee shall pay a fee in advance in the amount of \$1.00 inclusive of HST or any sales tax applicable and make a further such payment of on the anniversary of this date every year for the duration of this permit.

PAYMENT OF THE FEE

7.
 - (a) The Permittee shall make all payments by cheque drawn in favour of the Receiver General of Canada and shall deliver such payments to Indian Affairs and Northern Development, Regional Office South, 25 St. Clair Ave East, 8th Floor, Toronto, Ontario, or to such other place as the Minister may from time to time designate and notify the Permittee of in writing.
 - (b) The Permittee shall pay the fee in the manner set forth herein without any abatement or deduction whatsoever.
 - (c) Acceptance of the fee by the Minister, whether or not the Permittee is in arrears, shall not constitute a waiver by Her Majesty of compliance with any of the covenants, terms and conditions of this Permit or of Her Majesty's rights with respect to any rights reserved to Her Majesty in this Permit.

NO TENANCY

8.
 - (a) This Permit does not create for the Permittee any rights of tenancy or any possessory rights of exclusive use or occupation by implication or otherwise.
 - (b) The Minister reserves the right to grant permits, rights of way and other privileges or authorizations to enter upon, over, under, through or across the Permit Area, but no such permit, right of way, privilege or authorization shall interfere with the purposes set out in Article 4.

CO-ACCESS

9.
 - (a) The Permittee **will** use the Permit Area in common with the Mohawks of the Bay of Quinte and all other persons having a legal right to use and occupy the Permit Area.
 - (b) The Permittee, its officers, employees, agents and contractors shall have the right of ingress and egress to and from the Permit Area over reserve

access roads and rights of way in common with others legally entitled thereto, and shall have the right to unload and store material, as is reasonably necessary, on the Permit Area for the purposes set out in Article 4.

INDEMNITY

10. The Permittee shall at all times hereafter indemnify and save harmless Her Majesty and any other person having an interest in or a right or privilege to use the Permit Area including, without limiting the generality of the foregoing, the Mohawks of the Bay of Quinte First Nation and its members, from any and all claims, demands, losses, costs, damages, actions, suits or other proceedings that may be brought, instituted, claimed or made against any or all of them relating to or arising directly or indirectly as a consequence of:
- (a) any breach, violation or non-performance of any term or condition of this Permit by the Permittee, its officers, employees, agents and contractors, and
 - (b) any damage to property, including damage to the environment and economic loss, or any injury to any person, including death, arising wholly or in part as a consequence of the performance or purported performance of any term or condition of this Permit, including any act of omission by the Permittee, its officers, employees, agents, and contractors in the exercise or purported exercise of the rights authorized herein.

INSURANCE

11. (a) The Permittee shall maintain at its own cost and expense with one or more companies satisfactory to the Minister, commercial general liability insurance in the joint names of the Permittee and Her Majesty in a form satisfactory to the Minister against claims for personal injury, death or property damage occurring on or about the Permit Area, arising out of or resulting from the Permittee's use and occupation of the Permit Area, such insurance to afford protection of Her Majesty's interest and in no event to a minimum limit of **Five Million Dollars (\$5,000,000.00)** or to such other limit as may be set from time to time by the Minister in writing.
- (b) The Permittee shall, during the permit period, maintain at its own cost and expense fire and property damage insurance in a form satisfactory to the Minister insuring Her Majesty and the Permittee against loss by fire or other insurable causes of property damage to the Permittee's property and/or Permittee's improvements in the Permit Area.
- (c) The Permittee will send to the Minister certificates evidencing every policy of insurance which the Permittee has covenanted to take out, within thirty (30) days of the commencement of the Permit Period and a certificate of renewal at least five (5) days prior to the date of the expiration of any policy in force. In the event that the Permittee fails to effect such insurance or renewal thereof or to furnish a certificate, the Minister may procure such insurance and the premium paid by the Minister will be deemed to be additional rent due and payable by the Permittee to Her Majesty forthwith.
- (d) The Permittee releases Her Majesty, Her heirs and successors, from all liability for personal injury, death and property damage caused by any of the perils against which the Permittee has covenanted to insure, even though such loss or damage may arise out of negligence of Her Majesty or the Minister.

PAYMENT OF TAXES AND CHARGES

12. (a) The Permittee shall pay and discharge all rates, taxes, duties and assessments whatsoever now charged or hereafter to be charged by any competent authority upon the Permit Area or the Permittee in respect of the Permittee's use and occupation of the Permit Area.
- (b) The Permittee shall pay and discharge all charges related to the consumption of services relating to the Permit Area and the Permittee's use and occupation of the Permit Area including, but not limited to, security systems, water purification, water delivery, water pumping and cisterns, heating, hydro, oil, natural gas and telephone within the Permit Area.

ASSIGNMENT/TRANSFER

13. The Permittee shall not assign, sublet, transfer or otherwise encumber the rights authorized herein.

COMPLIANCE WITH APPLICABLE LAWS

14. (a) The Permittee shall conduct all activities on the Permit Area in compliance with all relevant and applicable band by-laws and all laws, requirements, directions, orders, ordinances, rules and regulations of Canada and the Province of Ontario and the Tyendinaga Mohawk Council or an agency thereof, including, without limiting the generality of the foregoing, all applicable environmental protection legislation, regulations, guidelines and orders.
- (b) The Permittee shall have the right to contest the validity of such by-laws, laws, requirements, directions, orders, ordinances and regulations, if proceedings relating thereto are commenced before the expiration of sixty (60) days after the Permittee was notified of any breach of such by-laws, laws, requirements, directions, orders, ordinances, and regulations.
- (c) The Permittee covenants that each time it contests the validity of any such by-laws, laws, requirements, directions, orders, ordinances, or regulations, the Permittee shall
 - (i) indemnify and hold harmless Her Majesty from all losses, damages, costs and expenses suffered by Her Majesty by reason of the Permittee undertaking such proceedings, and
 - (ii) conduct such proceedings expeditiously and with all reasonable diligence.

STATE OF REPAIR

15. The Permittee shall at its own expense, during the Permit Period, keep and maintain its Improvements and any materials in the Permit Area in good and safe repair and in a condition satisfactory to the Minister. The Minister may from time to time give the Permittee notice in writing of those repairs which, in the opinion of the Minister, are required and the Permittee will make such repairs at its sole expense, according to such notice.

RUBBISH

16. The Permittee shall not commit or permit the commission of any voluntary waste, spoilage or destruction or dump any rubbish or any other matter of an offensive nature anywhere on the Permit Area or elsewhere on the Reserve, except on such places and at such times as may be permitted and designated by the Tyendinaga Mohawk Council. The Permittee shall safely remove from the Reserve all solid wastes arising from its use and occupation of the Permit Area.

NUISANCE

17. Where in the opinion of the Minister a nuisance exists on the Permit Area, the Minister may order the Permittee to abate the nuisance and clean up the Permit Area. If the Permittee fails to do so, the Minister may take whatever steps that are, in the opinion of the Minister, necessary to abate the nuisance and the Permittee shall be liable for the costs thereof and the costs may be collected in the same manner as other debts due to the Crown.

HAZARDOUS ACTS

18. In exercising rights or carrying out its obligations under this Permit, the Permittee shall not knowingly or without due diligence commit any act or omission that may directly or indirectly cause, prolong or increase any hazard to any person or to the environment.

ENVIRONMENTAL STANDARDS

19. Without limiting the generality of Article 14, the Permittee shall at all times conduct all activities on the Permit Area in compliance with all applicable environmental laws, rules, regulations, notices or orders of Canada, the Province of Ontario, and the Tyendinaga Mohawk Council.

NO CONTAMINANTS

20. Without limiting the generality of Article 14, the Permittee shall not use, emit, discharge or store, or cause or permit to be used, emitted, discharged or stored, in the Permit Area or on any adjacent land any contaminants or toxic substances as defined under the *Canadian Environmental Protection Act* or corresponding legislation of the Province of Ontario, notwithstanding whether such provincial legislation is applicable on reserve land, except in strict compliance with applicable laws, rules, regulations, orders and approvals, whether or not such contaminants or toxic substances are presently defined or designated.

NO RESIDUAL OR ADVERSE IMPACT

21. The Permittee covenants that at all times there shall be no residual or adverse environmental impacts to the Permit Area as a result of or attributable to the use made of the Permit Area or the operation and activities of the Permittee, its employees, agents, contractors and invitees.

MITIGATION OF ENVIRONMENTAL IMPACTS

22. (a) The Permittee shall notify the Minister of any anticipated or actual adverse environmental impacts immediately upon discovery by the Permittee.

- (b) The Permittee agrees to implement appropriate technology, design or repairs to mitigate anticipated or actual adverse environmental impacts.
- (c) The Permittee shall implement such mitigation measures within a reasonable time following discovery, or on notice from the Minister, of the anticipated or actual adverse environmental impacts.
- (d) The Permittee shall permit the Minister to enter the Permit Area at all times to inspect and monitor the Permittee's activities and to ensure that the Permittee has taken all necessary steps to mitigate any anticipated or actual adverse environmental impacts to the satisfaction of the Minister.

LIABILITY FOR REMEDIAL ACTION

23. The Permittee shall pay and be responsible for the entire costs of any remedial action which in the opinion of the Minister is necessary to mitigate any damage caused to the environment arising from or attributable to the use and occupation of the Permit Area or the operation and activities of the Permittee, its officers, employees, agents and contractors.

HUNTING

24. The Permittee shall not hunt or permit hunting on the Permit Area.

TREES

25. The Permittee shall not cut or permit to be cut any trees on the Permit Area, or remove or permit to be removed any trees from the Permit Area, without the prior written consent of the Tyendinaga Mohawk Council and Minister.

APPROVAL OF CONSTRUCTION, EXTENSIONS OR RELOCATION

26. (a) The Permittee shall not construct, extend or relocate any works whatsoever for the purposes of distribution except with the consent of both the Minister and the Tyendinaga Mohawk Council Council given pursuant to this Article.
- (b) The Permittee shall deliver to the Minister and the Tyendinaga Mohawk Council separate notices of each such proposed construction, extension or relocation of any works for the purposes of distribution accompanied by a plan detailing the location and nature of the proposed construction, extension or relocation.
- (c) The consent of the Tyendinaga Mohawk Council shall not be deemed to have been given unless given by a Mohawk Council Resolution that has appended to it as a schedule, a copy of the plan referred to in paragraph (b) above.
- (d) If the Minister and the Tyendinaga Mohawk Council both consent to the proposed construction, extension or relocation of any works for the purposes of distribution, the Permittee shall perform the proposed work in accordance with the plan referred to in paragraph (b) above.
- (e) Notwithstanding the foregoing, the Permittee shall not construct, demolish, alter, remodel or replace any buildings whatsoever except in accordance with the standards set out in the National Building Code of Canada, the National Fire Code of Canada and the Canadian Plumbing Code in effect at the date of such work.

- (f) The approval of the Minister, in granting the consent in paragraph (d) above, shall not be taken as a representation or warranty of the soundness or quality of the work proposed.

ARCHAEOLOGICAL RESOURCES

- 27. (a) The Permittee shall promptly notify the Tyendinaga Mohawk Council and the Minister of any archaeological resources discovered or found on the Permit Area by the Permittee, its officers, employees, agents, contractors or third parties.
- (b) Upon receipt of notice pursuant to paragraph (a) above, the Tyendinaga Mohawk Council may order the Permittee to cease work to enable the Mohawks of the Bay of Quinte to conduct an archaeological excavation of the site on which the archaeological resources referred to in paragraph (a) above were discovered or found.
- (c) The Permittee hereby acknowledges that the archaeological resources referred to in paragraph (a) above or any archaeological resources uncovered during or following an excavation under paragraph (b) above are the property of the Mohawks of the Bay of Quinte First Nation and hereby agrees that it will promptly remit all such archeological resources to the Tyendinaga Mohawk Council.

DISPOSITION OF IMPROVEMENTS

- 28. (a) Subject to paragraph (b), at the expiration or sooner termination of this Permit, the Permittee shall peaceably yield up use and occupation of the Permit Area to Her Majesty free from all contaminants and toxic substances referred to in article 20 and free from all debris and in a state satisfactory to the Minister. Provided that if the Permittee is not in default of any of the terms and conditions herein contained, the Permittee shall have the right to remove the improvements it erected or constructed on the Permit Area at its own expense and without damage to the Permit Area. Until the improvements are removed, the obligations of the Permittee under this Permit shall remain in force.
- (b) If the Permittee does not remove all improvements within sixty (60) days of the expiration or sooner termination of this Permit, the Minister, after consulting with the Mohawks of the Bay of Quinte, may give notice to the Permittee declaring that the improvements are the property of Her Majesty, without the payment of compensation to the Permittee or directing the Permittee to remove the improvements. The Minister may take all actions that are in the opinion of the Minister necessary to remove the improvements and to restore the Permit Area, and all costs, expenses and damages incurred by the Minister shall be paid by the Permittee.

MINERAL RIGHTS

- 28.1 Her Majesty reserves the right to drill for, remove and dispose of petroleum, natural gas, and minerals on or under the Permit Area and for that purpose to drill wells, lay pipelines and build such tanks, stations and structures as may be necessary and in the lawful exercise of any of the rights hereby reserved;

DEEMED ACTS & OMISSIONS

31. Any act or omission that is an act or omission of the Permittee's officers, employees, agents, contractors or any other person acting on behalf of or under the direction of the Permittee shall be deemed to be an act or omission of the Permittee.

TERMINATION WITH NOTICE

32. Without prejudice to the Minister's right of termination under Article 34 or the right of cancellation under Article 35, if the Permittee is in default of any term or condition of this Permit the Minister may deliver a notice of default to the Permittee describing the default. If the Permittee fails to rectify the default with thirty (30) days of receipt of notice, the Minister may terminate this Permit by delivering a notice of termination to the Permittee and the termination notice shall be effective immediately upon receipt. Any right of action or remedy of the Minister or of any other person against the Permittee in respect of any antecedent breach of this Permit shall continue and shall not be prejudiced or otherwise affected, and for greater certainty Articles 15, 18 and 27 shall remain in full force and effect.

INSOLVENCY

33. If the Permittee shall at any time during the permit period
 - (a) file a petition in bankruptcy or make an assignment for the benefit of creditors,
 - (b) be adjudicated a bankrupt or insolvent,
 - (c) file any petition or institute any proceeding under any bankruptcy or insolvency legislation seeking to affect a reorganization or a composition,
 - (d) have its rights under this Permit seized in execution or by a process of law and not released within thirty (30) days from the day of such seizure; provided that the delivery of a Writ of Execution or a Writ of Extent to a Sheriff shall not be considered a seizure for the purpose of this provision,
 - (e) be subject to the appointment of a receiver or trustee who is not discharged within sixty (60) days from the date of such appointment, or commenced proceedings to wind up,

the Minister may, without notice to the Permittee, declare this Permit terminated, whereupon the Permit and the Permittee's rights under the Permit shall absolutely cease, determine and be void without any act, suit or proceeding being brought or taken.

If any of the events referred to in article 34 above occur, Her Majesty shall nevertheless be entitled to recover from the Permittee any fees accrued or accruing, and moreover that any right or action by Her Majesty against the Permittee in respect of any antecedent breach of any of the covenants, provisions, or terms and conditions contained in this Permit shall not be thereby prejudiced.

CANCELLATION

34. (a) The Minister may cancel this Permit for whatever reason, by a notice in writing, giving the Permittee 90 days notice as the Minister may in his discretion decide.
- (b) Such cancellation shall not prejudice Her Majesty's right to recover from the Permittee the permit fees accrued or accruing, or any other right of action arising from, under or in respect of this Permit.

SUBJECT TO THE INDIAN ACT

35. (a) The Permittee and the Minister mutually covenant and agree that this Permit is authorized under subsection 28(2) of the *Indian Act* and that the rights granted hereby shall be construed as personal contractual rights only and shall not be deemed to grant, convey or confer on the Permittee any right in return or any estate or interest in the title the Permit Area. Notwithstanding anything contained in this Permit, the Permittee on behalf of itself, its officers, employees, agents, contractors, sub-contractors and invitees acknowledges and agrees that this Permit does not confer or give rise to any greater right or rights on the Permittee, its officers, employees, agents, contractors, sub-contractors, and invitees than the Minister is authorized to confer by subsection 28(2) of the *Indian Act*.

This Permit shall be subject to the provisions of the *Indian Act*.

SUBJECT TO THE ENVIRONMENTAL ASSESSMENT ACT

36. The issuance of this Permit shall be subject to the application of the *Canadian Environmental Assessment Act, 2012* as amended or replaced from time to time.

RESOLUTION OF DISPUTES

37. (a) In the event of a dispute between the Permittee and the Minister concerning the interpretation of the terms and conditions of this Permit, except the conditions set out in Articles 6 and 23, the Minister, the Tyendianga Mohawk Council and the Permittee shall meet to discuss the issue in dispute and shall make all reasonable efforts to resolve the dispute.
- (b) In the event the Minister and the Permittee are unable to reach an agreement, the matter in dispute may be referred by either party to the Federal Court of Canada for resolution pursuant to section 17 of the *Federal Court Act*.

HEADINGS

38. The headings used in this Permit have been inserted for convenience only and shall not be used in the interpretation of any provision hereof.

TIME

39. Time shall be of the essence in respect of this Permit.

IN WITNESS WHEREOF the duly authorized representative of the Minister of the Department of Indian Affairs and Northern Development on behalf of Her Majesty the Queen in Right of Canada and the Permittee have hereunto set their hands or seals as of the date first written.

SIGNED , SEALED AND
DELIVERED in the presence of:

HER MAJESTY THE QUEEN in
right of Canada, as represented
by the Minister of Indian Affairs
and Northern Development

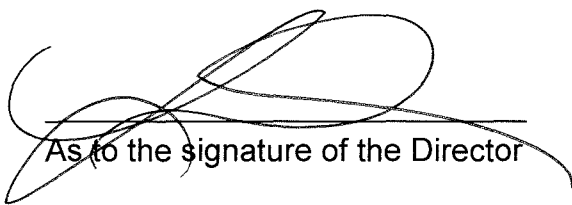

As to the signature of the Director

)
)
)
)
)

Director
Lands and Economic
Development
Ontario Region

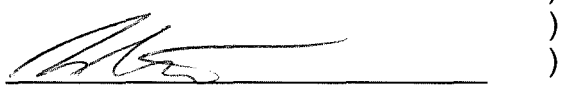

)
)
)
)
)

Permittee *John Bonin*

Appendix A

MOHAWK COUNCIL RESOLUTION

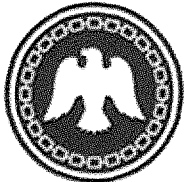

MOHAWKS OF THE BAY OF QUINTE

R.R. #1, Tyendinaga Mohawk Territory, Ontario K0K 1X0

Phone: (613) 396-3424 Fax: (613) 396-3627

MOHAWK COUNCIL RESOLUTION

Chronological No.:	2015/16-045
File Reference:	

NOTE: The words "From our First Nations Funds, "Capital" or "Revenue", which ever is the case, must appear in all resolutions requesting expenditures from First Nations Funds.

THE COUNCIL OF THE: MOHAWKS OF THE BAY OF QUINTE	Current Capital Balance	\$					
DISTRICT ONTARIO REGION SOUTH	Committed	\$					
PROVINCE ONTARIO	Current Revenue Balance	\$					
PLACE TYENDINAGA MOHAWK TERRITORY #38	Committed	\$					
DATE <table style="width:100%; border:none;"> <tr> <td style="text-align:center;">07</td> <td style="text-align:center;">August</td> <td style="text-align:center;">2015</td> </tr> <tr> <td style="text-align:center;">Date</td> <td style="text-align:center;">Month</td> <td style="text-align:center;">Year</td> </tr> </table>	07	August	2015	Date	Month	Year	
07	August	2015					
Date	Month	Year					

DO HEREBY RESOLVE:

Moved by: Barry Brant

Seconded by: Carl E. (Ted) Maracle

WHEREAS, Section 28(2) of the Indian Act provides that the Minister of Indian Affairs and Northern Development (the "Minister") has the authority to permit any person to occupy, use, reside or otherwise exercise rights on reserve;

WHEREAS, the Tyendinaga Mohawk Council negotiated terms for a 28(2) permit with Union as for the purpose of distribution of natural gas to the residences and other buildings located and to be located on the Reserve and for no other purpose whatsoever;

WHEREAS, the Tyendinaga Mohawk Council has now applied to the Minister to grant a Permit with the terms negotiated in respect of the Project;

WHEREAS, the Permit is to be for an indeterminate term commencing July 1, 2015 with the fee payable at the rate of one dollar (\$1.00) per annum along with other valuable considerations;

WHEREAS, the Tyendinaga Mohawk Council recognizes the benefit to the Mohawks of the Bay of Quinte and recognizes further, that the benefits will exceed the established permit fee;

WHEREAS, the Tyendinaga Mohawk Council, for the purpose of the Project, by way of Mohawk Council Resolution also resolved that a Waiver and Release be executed by the Tyendinaga Mohawk Council.

A quorum for this First Nation
Consists of 3
Council Members

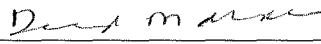
Chief R. Donald Maracle

Councillor Douglas E. Maracle

Councillor Barry Brant

Councillor Sandra Lewis-den Otter

Councillor Carl Ted Maracle

FOR DEPARTMENT USE ONLY

1. First Nation Code	2. COMPUTER BALANCES		3. Expenditure	4. Authority Indian Act See	5. Source of Funds <input type="checkbox"/> Capital <input type="checkbox"/> Revenue
	A. Capital \$	B. Revenue \$			
6. Recommended			Approved		
Date	Recommending Officer		Date	Approving Officer	



MOHAWKS OF THE BAY OF QUINTE

R.R. #1, Tyendinaga Mohawk Territory, Ontario K0K 1X0

Phone: (613) 396-3424

Fax: (613) 396-3627

MOHAWK COUNCIL RESOLUTION

Chronological No.:	2015/16-045
File Reference:	

NOTE: The words "From our First Nations Funds, "Capital" or "Revenue", which ever is the case, must appear in all resolutions requesting expenditures from First Nations Funds.

THE COUNCIL OF THE: MOHAWKS OF THE BAY OF QUINTE	Current Capital Balance	\$
DISTRICT ONTARIO REGION SOUTH	Committed	\$
PROVINCE ONTARIO	Current Revenue Balance	\$
PLACE TYENDINAGA MOHAWK TERRITORY #38	Committed	\$
DATE _____		
Date Month Year		

Now Therefore the Tyendinaga Mohawk Council hereby:

- a) Releases and saves harmless HER MAJESTY THE QUEEN IN RIGHT OF CANADA, Her officers, servants, agents and employees ("the Crown") from and against any and all liabilities, actions, causes of action, damages, claims and demands, including any costs and expenses, losses, suits or other proceedings, related to any loss, property damage, personal injury or death resulting from occasioned by, or in any way (including negligence) attributable to the construction, maintenance, or operation of the Project within the Tyendinaga Mohawk Territory No. 38;
- b) Waives any and all action, causes of action, damages, claims and demands of any nature or kind whether in contract or tort (including, but not limited to, negligence or intentional torts) or under any other laws, or pursuant to any principle, including, but not limited to, fiduciary duty, against the Crown, in any matter (including negligence) arising out of, based upon, occasioned by or attributable to the Crown's activities or the lack thereof, or any action taken or things done or maintained, or omitted to be taken, done or maintained by the Crown in respect of its execution and issuance of the Permit;

A quorum for this First Nation
Consists of 3
Council Members

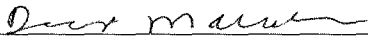
Chief R. Donald Maracle

Councillor Douglas E. Maracle

Councillor Barry Brant

Councillor Sandra Lewis-den Otter

Councillor Carl Ted Maracle

FOR DEPARTMENT USE ONLY

1. First Nation Code	2. COMPUTER BALANCES		3. Expenditure	4. Authority Indian Act See	5. Source of Funds <input type="checkbox"/> Capital <input type="checkbox"/> Revenue
	A. Capital \$	B. Revenue \$			
6. Recommended			Approved		
_____ Date Recommending Officer			_____ Date Approving Officer		



MOHAWKS OF THE BAY OF QUINTE

R.R. #1, Tyendinaga Mohawk Territory, Ontario K0K 1X0

Phone: (613) 396-3424

Fax: (613) 396-3627

MOHAWK COUNCIL RESOLUTION

Chronological No.:	2015/16-045
File Reference:	

NOTE: The words "From our First Nations Funds, "Capital" or "Revenue", which ever is the case, must appear in all resolutions requesting expenditures from First Nations Funds.

THE COUNCIL OF THE: MOHAWKS OF THE BAY OF QUINTE	Current Capital Balance	\$					
DISTRICT ONTARIO REGION SOUTH	Committed	\$					
PROVINCE ONTARIO	Current Revenue Balance	\$					
PLACE TYENDINAGA MOHAWK TERRITORY #38	Committed	\$					
DATE <table border="0" style="width:100%"> <tr> <td style="text-align:center">07</td> <td style="text-align:center">August</td> <td style="text-align:center">2015</td> </tr> <tr> <td style="text-align:center">Date</td> <td style="text-align:center">Month</td> <td style="text-align:center">Year</td> </tr> </table>	07	August	2015	Date	Month	Year	
07	August	2015					
Date	Month	Year					

- c) Acknowledges that in the event any proceedings in connection with any of the matters outlined herein are brought by the Tyendinaga Mohawk Council or any of their members, this Waiver and Release may be pleaded by the Crown as a complete defense and reply and may be relied upon by the Crown in any proceedings to have that proceeding dismissed on a summary basis.
- d) Requests a permit pursuant to Section 28(2) of the Indian Act be issued substantially in the form of the one appended.

Carried.

A quorum for this First Nation
Consists of 3
Council Members

Chief R. Donald Maracle

Councillor Douglas E. Maracle

Councillor Barry Brant

Councillor Sandra Lewis-den Otter

Councillor Carl Ted Maracle

FOR DEPARTMENT USE ONLY

1. First Nation Code	2. COMPUTER BALANCES		3. Expenditure	4. Authority Indian Act See	5. Source of Funds <input type="checkbox"/> Capital <input type="checkbox"/> Revenue
	A. Capital \$	B. Revenue \$			
6. Recommended			Approved		
Date			Date		
Recommending Officer			Approving Officer		

Registration Control Sheet / Fiche de contrôle des enregistrements

Received / Reçue _____ Sec 53 and/or 60 Bands
 Bandes visées par l'article 53 et/ou 60 _____

Registration No. / No d'enregistrement 60091209

Date: March 11, 2016

Time / Heure: 10:27:45 AM / PM

Pending File No. / N° du dossier en attente: 60091209 Region / Région: ON

Reserve Name / Nom de la réserve: OWIF Tyendinaga

Instrument Type / Type d'instrument: Permit Purpose / Objet: _____

Term / Durée: _____ From / Du: _____ To / Au: _____

Retire PIN / Retirer le NIP Yes / Oui No / Non EOT Required: / PDT exigée: Yes / Oui No / Non

_____ Cancels EOT / PDT annulée: _____

PIN(s) / NIP(s) _____ Legal Description/Land Affected / Description légale/Terre affectée

OWIF: _____ Tyendinaga Mohawk Territory
(Reserve General)

Remarks/Registration Numbers Affected / Observations/Numéros d'enregistrement touchés

Distribution & Transmission

Examined By/ Examinée par: [Signature] Date: 3/11/16

Verified By: / Vérifiée par: _____ Date: _____

CIDM#4060466

ENBRIDGE GAS INC.

Answer to Interrogatory from
OEB Staff ("STAFF")

INTERROGATORY

Reference:

Exhibit F, Tab 1, Schedule 1: Environmental Matters and Attachment 2: dated December 20, 2022

Enbridge Gas retained Dillon Consulting Ltd. (Dillon) to complete an Environmental Report: Mohawks of the Bay of Quinte and Shannonville Community Expansion Project (ER). The ER assessed the existing bio-physical and socio-economic environment in the study area, the alternative routes, proposed the preferred route, conducted public consultation, conducted impacts assessment and proposed mitigation measures to minimize the impacts. The ER and the consultation process were conducted in accordance with the OEB's Environmental Guidelines for Location, Construction and Operation of Hydrocarbon Pipelines in Ontario [7th Edition, 2016] (OEB Environmental Guidelines).

Enbridge Gas sent the ER to Mohawks of the Bay of Quinte First Nation (MBQFN) on July 20, 2022 and to other Indigenous communities on August 15, 2022. On August 12, 2022 Enbridge Gas sent the ER for review and comments to the Ontario Pipeline Coordinating Committee (OPCC) members.

Question:

- a) Please update the filed Correspondence Tracking with the OPCC and specify any new concerns raised since filing the application on December 20, 2022.
- b) Please describe the status and prospects of resolution of any outstanding concerns raised in the OPCC review and Enbridge Gas's plans to address the outstanding concerns.

Response

- a) Please see Attachment 1 to this response for the updated Correspondence Tracking up until April 6, 2023.

- b) There are no outstanding issues or concerns resulting from the OPCC review at this time.

Line Item	Date of Consultation	Name of Agency and/or Contact	Description of Consultation Activity	Date of Response	Response and Issue Resolution (if applicable)
ONTARIO PIPELINE COORDINATING COMMITTEE (OPCC)					
1.1	August 12, 2022	OPCC-TSSA representative <i>Contact: Kourosh Manouchehri</i>	Enbridge Gas representative sent the link to the Environmental Report and requested all feedback be provided by September 30, 2022.	August 15, 2022	The TSSA representative emailed Enbridge Gas representative to thank them for the information and state that an Application for Review of a Pipeline Project needs to be filled out as part of the Ontario Pipeline Coordinating Committee.
1.2	August 15, 2022	OPCC-TSSA representative <i>Contact: Kourosh Manouchehri</i>	Enbridge Gas representative thanked them for the information and advised that they will fill out the application.	N/A	N/A
2.1	August 12, 2022	OPCC –OEB Representative <i>Contact: Zora Crnojacki</i>	Enbridge Gas representative sent the link to the Environmental Report and requested all feedback be provided by September 30, 2022.	N/A	N/A
3.1	August 12, 2022	OPCC – OMAFRA Representative <i>Contact: Helma Geerts</i>	Enbridge Gas representative sent the link to the Environmental Report and requested all feedback be provided by September 30, 2022.	N/A	N/A
4.1	August 12, 2022	OPCC – MMAH Representative Central Municipal Services Office <i>Contact: Maya Harris</i>	Enbridge Gas representative sent the link to the Environmental Report and requested all feedback be provided by September 30, 2022.	N/A	N/A
5.1	August 12, 2022	OPCC – MMAH Representative Municipal Services Office – North <i>Contact: Bridget Schulte-Hostedde</i>	Enbridge Gas representative sent the link to the Environmental Report and requested all feedback be provided by September 30, 2022.	N/A	N/A
6.1	August 12, 2022	OPCC – MMAH Representative Eastern Municipal Services Office <i>Contact: Mike Elms</i>	Enbridge Gas representative sent the link to the Environmental Report and requested all feedback be provided by September 30, 2022.	N/A	N/A
7.1	August 12, 2022	OPCC – MOE Representative <i>Contact: Amy Gibson</i>	Enbridge Gas representative sent the link to the Environmental Report and requested all feedback be provided by September 30, 2022.	N/A	N/A
8.1	August 12, 2022	OPCC – MCM Representative <i>Contact: Karla Barboza</i>	Enbridge Gas representative sent the link to the Environmental Report and requested all feedback be provided by September 30, 2022.	N/A	N/A
9.1	August 12, 2022	OPCC – NDMNRF Representative <i>Contact: Keith Johnston</i>	Enbridge Gas representative sent the link to the Environmental Report and requested all feedback be provided by September 30, 2022.	N/A	N/A

Line Item	Date of Consultation	Name of Agency and/or Contact	Description of Consultation Activity	Date of Response	Response and Issue Resolution (if applicable)
10.1	August 12, 2022	OPCC – Infrastructure Ontario Representative <i>Contact: Cory Ostrowka</i>	Enbridge Gas representative sent the link to the Environmental Report and requested all feedback be provided by September 30, 2022.	N/A	N/A
11.1	August 12, 2022	OPCC – MTO Representative <i>Contacts: Tony DiFabio</i>	Enbridge Gas representative sent the link to the Environmental Report and requested all feedback be provided by September 30, 2022.	N/A	N/A
12.1	August 25, 2022	OPCC – MTO Representative <i>Contact: Amanda Rodek</i>	MTO representative emailed Enbridge Gas to provide their feedback on the Environmental Report.	August 25, 2022	Enbridge Gas representative thanked MTO representative for their email and advised that they had received a response from a different representative at MTO on August 16, 2022. Enbridge Gas representative noted that however we acknowledge your submission and confirm that Enbridge Gas will keep in touch with the MTO as the project progresses through design.
13.1	September 28, 2022	OPCC-MCM Representative and OEB Representative <i>Contact: Laura Hatcher, Zora Crnojacki</i>	MCM representative provided comments on the Environmental Report relating to archaeological resources, built heritage, and environmental inspectors and monitors.	September 28, 2022	<p>Enbridge Gas representative provided responses to MCM representative's comments. Enbridge Gas stated that they plan to have indigenous review of the Stage 1 Archaeological Assessment Report to allow comments during the OPCC review. The goal is to capture all stakeholder comments before submitting the Final Environmental to the OEB or the Stage 1 AA to MCM.</p> <p>Enbridge Gas representative stated that a Cultural Heritage Screening Checklist was completed for the Project and indicated that a Cultural Heritage Assessment Report is required and will be included in the Environmental Protection Plan.</p> <p>Enbridge Gas representative acknowledged the comment regarding archaeologists only be employed to monitor impacts to archaeological resources.</p>
13.2	October 18, 2022	OPCC-MCM Representative and OEB Representative <i>Contact: Laura Hatcher, Zora Crnojacki</i>	MCM representative thanked Enbridge Gas representative for their response. MCM representative stated that they advise the Stage 1 Archaeological Assessment should be reviewed and by the ministry and accepted onto the <i>Ontario Public Register of Archaeological Reports</i> prior to the completion of the Environmental Report. MCM also recommended that the Cultural Heritage Assessment Report is completed at this stage to inform the Environmental Report.	October 25, 2022	Enbridge Gas representative noted that it allows indigenous communities to review and comment prior to the submission to MCM and mitigates project risk. Enbridge Gas representative noted that all mitigation, commitments and recommendations for the project make it into the Environmental Protection Plan and stated that at times it is not feasible to complete a Cultural Heritage Assessment Report as part of the Environmental Assessment Process. Enbridge Gas representative noted that if time permits they intend to provide archaeological and cultural heritage reports prior to Environmental Report submission.
14.1	August 12, 2022	OPCC – MECP Representative <i>Contacts: Katy Potter</i>	Enbridge Gas representative sent the link to the Environmental Report and requested all feedback be provided by September 30, 2022.	N/A	N/A

Line Item	Date of Consultation	Name of Agency and/or Contact	Description of Consultation Activity	Date of Response	Response and Issue Resolution (if applicable)
14.2	March 2, 2023	OPCC – MECP Representative <i>Contacts: Katy Potter, Jon Orpana</i>	Dillon representative emailed MECP representative to request their input on the Species at Risk Habitat Assessment and Summary Memo by March 17, 2023.	March 2, 2023	MECP representative advised that they changed positions within the MECP and copied the new Project Review Unit Supervisor (Gavin Battarino).
14.3	March 2, 2023	OPCC – MECP Representative <i>Contact: Katy Potter</i>	Dillon representative thanked MECP representative for letting them know about the Project Review Unit Supervisor staffing change.	N/A	N/A
14.4	March 13, 2023	OPCC – MECP Representative <i>Contacts: Gavin Battarino, Jon Orpana</i>	Dillon representative sent the Species at Risk Habitat Assessment and Summary Memo to the new MECP Project Review Supervisor and asked if they would be able to provide comments by March 17, 2023.	March 13, 2023	Automatic reply from MECP Project Review Unit Supervisor advising to reach out to Trevor Bell in their absence. Dillon representative forwarded email to Trevor Bell.
14.5	March 13, 2023	OPCC – MECP Representative <i>Contact: Jon Orpana</i>	MECP representative emailed Dillon representative to note that MECP Regional Planners do not have the training to review materials related to Species at Risk and noted that it is customary for Enbridge Gas to circulate these materials to the Species at Risk enquiry inbox.	March 14, 2023	MECP representative followed up to their previous email to note that the Species at Risk biologist is off for March Break and likely will not review the materials until the end of the month. MECP representative noted that they provided the Species at Risk Biologist the shapefiles at the Notice of Commencement stage so the memo should not be a surprise to them. MECP representative stated that the Species at Risk Branch and Source Protection Branches are usually circulated project notices.
14.6	March 14, 2023	OPCC – MECP Representative <i>Contact: Jon Orpana</i>	Dillon representative thanked the MECP representative for the additional information. Dillon representative noted that the Notice of Commencement was forwarded to the Source Protection Branch and Species at Risk Branch, however the memo was not. Dillon representative asked if MECP representative forwarded the memo on Dillon's behalf.	March 14, 2023	MECP representative noted that Trevor Bell is filling in for Gavin Battarino while they are on vacation, but the biologist is away for March Break so no review will occur until the biologist returns. MECP representative advised that they did forward the Species at Risk Habitat Assessment and Summary Memo to the Species at Risk Branch.
14.7	March 14, 2023	OPCC – MECP Representative <i>Contact: Jon Orpana</i>	Dillon representative thanked MECP representative.	N/A	N/A
14.8	April 6, 2023	OPCC – MECP Representative <i>Contacts: Gavin Battarino, Jon Orpana</i>	Dillon representative emailed MECP representative to follow up on the review of the Species at Risk Habitat Assessment and Summary Memo and asked if comments could be provided by April 14, 2023. Dillon representative requested that if the stated timeline does not work for them, they provide an anticipated timeline for providing their comments.	N/A	N/A

ENBRIDGE GAS INC.

Answer to Interrogatory from
OEB Staff ("STAFF")

INTERROGATORY

Reference:

Exhibit F, Tab 1, Schedule 1: Environmental Matters and Attachment 2: Environmental Report Review Correspondence, December 20, 2022, page 1, item 4.2

The Technical Standards and Safety Authority (TSSA) is a member of the Ontario Pipeline Coordinated Committee. The TSSA reviewed the Environmental Report and the Project specification and design. On August 15, 2022 the TSSA requested that Enbridge Gas file with the TSSA an application related to the design and operational characteristics of the pipeline. The TSSA protocol requires that upon review it issues a letter to Enbridge Gas summarizing its review of the pipeline design characteristics.

Question:

- a) When did Enbridge Gas file the TSSA's required application? What is the status of the application review and the anticipated timing to receive a TSSA's letter acknowledging that the pipeline design and operating characteristics are compliant with the applicable regulatory standards?

Response

- a) Enbridge Gas filed an *Application for Review of Pipeline Project* with the TSSA on Thursday, April 6, 2023. At this time, Enbridge Gas has not received any comments and assumes there are no issues with compliance or applicable regulatory standards based on previously approved projects. The Company expects to receive TSSA approval in advance of commencing Project Construction.

ENBRIDGE GAS INC.

Answer to Interrogatory from
OEB Staff ("STAFF")

INTERROGATORY

Reference:

Exhibit F, Tab 1, Schedule 1, Attachment 1: Environmental Report: Mohawks of the Bay of Quinte and Shannonville Community Expansion Project

Enbridge Gas is required to complete a Cultural Heritage Assessment Report (CHAR) prior to construction and submit it to the Ministry of Citizenship and Multiculturalism (MCM) for their review and comment as required by the Ontario Heritage Act. The Environmental Report stated that Enbridge Gas would complete and submit the CHAR to the MCM prior to construction.

Question:

- a) What is the status of the CHAR for the Project and when is the anticipated date of filing the CHAR with the MCM for review?

Response

- a) A CHAR was completed by Dillon Consulting and submitted to the MCM on December 6, 2022. Enbridge Gas received comments from the MCM regarding the CHAR on January 13, 2023. The updated CHAR was resubmitted to the MCM on April 4, 2023. The MCM confirmed there were no further concerns on April 11, 2023.

ENBRIDGE GAS INC.

Answer to Interrogatory from
OEB Staff ("STAFF")

INTERROGATORY

Reference:

Exhibit E, Tab 1, Schedule 1, Attachment 1: Environmental Report: Mohawks of the Bay of Quinte and Shannonville Community Expansion Project, Appendix A, Draft Stage 1 Archaeological Assessment Stage 1 Report

Enbridge Gas completed the Stage 1 Archaeological Assessment (AA) on July 20, 2022. The Draft Stage 1 AA Report is filed in Appendix A of the Environmental Report. Enbridge Gas stated that a Stage 2 AA is underway. Enbridge Gas noted it would submit a combined Stage 1 AA and Stage 2 AA final report to the MCM for review and approval prior to the construction start.

Question:

- a) What is the status of the Archeological Assessment Stage 2 and when is the anticipated date of filing the Archaeological Assessment Stage 2 Report with the MCM for a review?

Response

- a) The Stage 2 AA has been submitted to Indigenous communities for review. Comments from Hiawatha First Nation have been received and incorporated into the Stage 2 AA. Enbridge Gas anticipates that it will also receive comments from MBQ and will work with MBQ to ensure such comments are reviewed in a careful and respectful manner. Enbridge Gas expects to submit the Stage 2 AA to the MCM in May 2023, pending receipt and resolution of all remaining comments on the report, and expects the MCM to enter it onto the Public Register in advance of the commencement of Project construction.

ENBRIDGE GAS INC.

Answer to Interrogatory from
OEB Staff (“STAFF”)

INTERROGATORY

Reference:

Exhibit G, Tab 1, Schedule 1, pages 1 and 2, paragraph 4

Enbridge Gas identified in its application the entities that would require approvals, permits and land easements for location, construction and operation of the Project.

Question:

- a) Please provide the status and anticipated time of each permit/approval application and the expected date of acquiring each of the permits.
- b) Please describe and discuss any risk of not acquiring the permits on time to the planned project construction schedule and in-service date?

Response

- a) Please see Table 1 for the current status and anticipated date of receipt of Project-specific permits/approvals.

Table 1: Status of Permits/Approvals

Permitting Authority	Status	Anticipated approval
Quinte Conservation Authority	Not required	N/A
Ministry of Citizenship and Multiculturalism (“MCM”)	In Progress Stage 1 and 2 archaeological assessment report is with Indigenous communities for review.	MCM acceptance of the Cultural Heritage Assessment Report was received on April 11, 2023
Ministry of Heritage, Sport, Tourism and Culture Industries (“MHSTCI”)	Not Required – moved to MCM authority	

Ministry of Environment, Conservation and Parks ("MECP")	In Progress	July 2023
Fisheries and Oceans Canada ("DFO")	Not required – Enbridge Gas will abide by the DFO and Enbridge Gas Inc. Agreement related to Watercourse Crossings for Pipeline Construction and Maintenance in Ontario. If Enbridge Gas cannot abide by the DFO Agreement, a project review by DFO is required.	N/A
Environment and Climate Change Canada ("ECCC")	In Progress	July 2023
Indigenous Services Canada ("ISC") (Indian Act (RSC, 1985, c. I-5))	In Progress	Notice was sent to ISC and MBQ with intent to move forward with application of the existing 28.2 permit on April 3 rd , 2023.
Indigenous Services Canada (Impact Assessment Act (SC 2019, c. 28, s. 1))	In Progress	July 2023
Ministry of Transportation (for station rebuild)	To be submitted	July 2023 (not required for construction of main)
Ontario Energy Board (Leave to Construct)	In Progress	June 2023
Township of Tyendinaga	No official process – in consultation with township staff for approval.	
Mohawks of the Bay of Quinte ("MBQ")	Band Council Resolution ("BCR")	The BCR is expected to be received by MBQ after April 2023 council meeting.

- b) Any delays to permit/approval receipt is likely to push the In-Service Date to Q1 or Q2 2024, depending on weather and length of delay. The latter could also cause Project construction to be executed over two years, in a phased approach, should there not be sufficient time to complete construction of the main-related portion of the Project and station rebuild in 2023. Should such changes be required, Enbridge Gas would notify and see approval from the OEB via a Change Request as applicable and subject to the Conditions of Approval established by the OEB in its Decision and Order for the current Application.

ENBRIDGE GAS INC.

Answer to Interrogatory from
OEB Staff ("STAFF")

INTERROGATORY

Reference:

Exhibit G, Tab 1, Schedule 1, pages 3 and 4, paragraphs 7-9

Enbridge Gas stated that the exact requirements for permanent easement will be determined upon completion of the station design. On the reserve lands held by the Crown and a consent of the MBQNFN Council and consent of Certificate of Possession holders may be required.

Question:

- a) Please update the status and prospects of the land permitting requirements and communication with the MBQFN Council and Certificate Possession holders on the Crown land. Please describe the updates in communication with MBQFN Council and Certificate Possession holders.
- b) Does Enbridge Gas anticipate the need for permanent land rights on lands other than Crown land? If so, identify the potential locations and directly affected landowners? Please discuss.

Response

- a) All-natural gas main infrastructure will be constructed within MBQFN road allowance, and will not require permission from Certificate Possession holders. Rather, a 28.2 permit is required, and Enbridge Gas is working with Indigenous Services Canada ("ISC") and Mohawks of the Bay of Quinte ("MBQ") to obtain this permit. Notice has been sent to ISC and MBQ on April 3rd, 2023, with the intent to move forward with requesting an extension on the existing 28.2 permit currently held by Enbridge Gas on existing assets within the territory. Associated documents relevant to the application of said permit are the Environmental Report ("ER") for the Project, as-laid pipeline drawings, and Band Council Resolutions ("BCR") related to approvals from MBQ to allow new assets to be installed within road allowance on MBQ territory. To date, Enbridge Gas has provided ISC and MBQ the ER and Project

scope/description and is awaiting the BCR from MBQ and as-laid drawings. Once those are received, they will be forwarded to both parties for review.

The station rebuild will likely require an extension of the existing station footprint. Discussion has been initiated with MBQFN on this subject and Enbridge Gas expects that a lease agreement may be required; as of the date of this filing no concerns have been expressed by any party with regard to establishing such an agreement.

- b) No. No permanent land rights are anticipated to be required within the Township of Tyendinaga portion of the Project area at this time.

ENBRIDGE GAS INC.

Answer to Interrogatory from
OEB Staff ("STAFF")

INTERROGATORY

Reference:

Exhibit H, Tab 1, Schedule 1 and Attachment 2: Delegation Letter; Attachment 5-ICR Summary Table; Attachment 6-ICR Log and Project Correspondence Environmental Report Review Correspondence

In accordance with the OEB's Environmental Guidelines, Enbridge Gas contacted the Ministry of Energy (MOE) on February 16, 2022 in respect to the requirements for Crown's duty to consult related to the Project. In response the MOE delegated the procedural aspects of the Crown's duty to consult for the Project to Enbridge Gas on April 3, 2022 (Delegation Letter). The Delegation Letter identified the following Indigenous communities to be consulted: Mohawks of the Bay of Quinte FN (MBQFN), Williams Treaties First Nations (specifically Alderville FN, Beausoleil FN, Chippewas of Georgina Island FN, Chippewas of Rama FN, Curve Lake FN, Hiawatha FN, and Mississaugas of Scugog Island), Kawartha Nishnawbe and Huron-Wendat Nation. The MOE assessed that for the Williams Treaties First Nations, Kawartha Nishnawbe FN, and Huron-Wendat Nation "...the consultation is required at the "low" end of the spectrum for this project.". The MOE required a deeper level of consultation with the MBQFN. The MOE provided in the Delegation Letter detailed information on the consultation level and roles and responsibilities delegated to Enbridge Gas.

Enbridge Gas filed the MOE its Indigenous Consultation Report (ICR) for the Project on December 20, 2022. The ICR is also filed with the OEB as part of the application. To date, Enbridge Gas has not filed with the OEB a letter from the MOE indicating that it reviewed the ICR and that, in its opinion, the procedural aspects of consultation undertaken by Enbridge Gas to date are satisfactory (Letter of Opinion).

Question:

- a) Please update the ICR Summary Table and the Log of Indigenous consultation activities since December 15, 2022.
- b) Please summarize any issues and concerns that each of the engaged Indigenous communities raised since December 20, 2022.

- c) If any issues were raised, please describe Enbridge Gas's plans, actions and commitments to address these concerns, resolve the outstanding issues and provide accommodation.
- d) Please update the evidence with any correspondence between the MOE and Enbridge Gas after December 20, 2022 regarding the MOE's review of Enbridge Gas's Indigenous consultation activities.
- e) Please obtain an update from the MOE on the status and anticipated timeline of receiving a Letter of Opinion for the Project.

Response

- a) Please see Attachment 1 to this response, which contains an update to the Indigenous Consultation Record ("ICR") Summary Table found at Exhibit H, Tab 1, Schedule 1 as of April 13, 2023. Attachment 2 provides an update to the ICR log, found at Exhibit H, Tab 1, Schedule 1, Attachment 6 from December 16, 2022 to April 13, 2023.
- b) Enbridge Gas received comments on March 2, 2023 from HFN on the Stage 2 AA report. See Line Item 6.17 at Attachment 2 to this response for details. Enbridge Gas is working to provide responses to these questions. MBQ provided comments on the Stage 2 AA orally on March 2 but has not yet provided them in writing. MBQ's concerns related to the historical context set out in the Stage 2 AA report. Specifically, the time frame of reserve land establishment and 19th and 20th century settlement of the area.
- c) The concerns raised by HFN regarding the Stage 2 AA around historical context can be found within the Stage 2 AA report. Enbridge Gas will carefully consider the comments provided by HFN and will provide HFN with a written response to the concerns that have been raised. Enbridge Gas appreciates the knowledge shared and will endeavour to incorporate this information in reports moving forward. Those concerns received orally from MBQ were concerns around historical reporting. Specifically, the establishment of reserve land and 19th and 20th century settlement of the area. MBQ advised Enbridge Gas that they will provide their concerns in writing and Enbridge Gas will respond to these concerns once received.
- d) and e)
Please see Attachment 3 to this response, which contains email correspondence with the MOE since December 20, 2022. The MOE provided Enbridge Gas with a letter of opinion regarding the sufficiency of consultation regarding the Project on

April 25, 2023 (please see Attachment 4 to this response). The MOE has determined that "...based on this review of materials and our outreach to Indigenous communities, ENERGY is of the opinion that the procedural aspects of consultation undertaken by Enbridge to-date for the purposes of the Ontario Energy Board's Leave to Construct for the Project are satisfactory."

INDIGENOUS CONSULTATION REPORT: SUMMARY TABLE

As of April 13, 2023

Alderville First Nation (AFN)		
<p>Was project information provided to the community?</p>	<p><input checked="" type="checkbox"/> Yes <input type="checkbox"/> No</p>	<p>Enbridge Gas has provided AFN with the following information:</p> <ul style="list-style-type: none"> • A detailed description of the nature and initial scope of the Project. This included a list of other provincial or federal approvals that may be required for the Project to proceed. • Maps of the Project location. • Letter containing information on the Virtual Open House. • Environmental Report, providing information about the potential effects of the Project on the Environment, including archaeological assessments. • Stage Two Archeology Assessment report (“AA”) <p>Enbridge Gas requested community feedback, including any suggestions or proposals on mitigating, avoiding or accommodating any potential impacts the Project may have on Aboriginal or treaty rights.</p>
<p>Was the community responsive/did you have direct contact with the community?</p>	<p><input checked="" type="checkbox"/> Yes <input type="checkbox"/> No</p>	<p>Enbridge Gas and an AFN representative have exchanged emails regarding the Project and had a phone call on May 2, 2022, to further discuss the Project.</p>
<p>Did the community members or representatives have any questions or concerns?</p>	<p><input checked="" type="checkbox"/> Yes <input type="checkbox"/> No</p>	<p>AFN expressed an interest in archaeology and in continuing to receive Project information, but has not raised any specific questions or concerns regarding the Project. AFN and Enbridge Gas had general discussions regarding the Project and ongoing engagement and Enbridge Gas will provide AFN with copies of available reports as requested.</p>
<p>Does the community have any outstanding concerns?</p>	<p><input type="checkbox"/> Yes <input checked="" type="checkbox"/> No</p>	<p>As of April 13, 2023, AFN has not identified any outstanding concerns related to the Project. Enbridge Gas will continue to engage with the community in relation to the Project.</p>

Beausoleil First Nation (BFN)		
<p>Was project information provided to the community?</p>	<p><input checked="" type="checkbox"/> Yes <input type="checkbox"/> No</p>	<p>Enbridge Gas has provided BFN with the following information:</p> <ul style="list-style-type: none"> • A detailed description of the nature and initial scope of the Project. This included a list of other provincial or federal approvals that may be required for the Project to proceed. • Maps of the Project location. • Letter containing information on the Virtual Open House. • Environmental Report, providing information about the potential effects of the Project on the Environment, including archaeological assessments. • Stage Two AA <p>Enbridge Gas requested community feedback, including any suggestions or proposals on mitigating, avoiding, or accommodating any potential impacts the Project may have on Aboriginal or treaty rights.</p>
<p>Was the community responsive/did you have direct contact with the community?</p>	<p><input checked="" type="checkbox"/> Yes <input type="checkbox"/> No</p>	<p>Enbridge Gas and a BFN representative have exchanged emails regarding the Project.</p>
<p>Did the community members or representatives have any questions or concerns?</p>	<p><input type="checkbox"/> Yes <input checked="" type="checkbox"/> No</p>	<p>BFN has not raised any questions or concerns regarding the Project. BFN and Enbridge Gas have had general discussions regarding the Project and ongoing engagement.</p>
<p>Does the community have any outstanding concerns?</p>	<p><input type="checkbox"/> Yes <input checked="" type="checkbox"/> No</p>	<p>As of April 13, 2023, BFN has not identified any outstanding concerns regarding the Project. Enbridge Gas will continue to engage with the community in relation to the Project.</p>

Chippewas of Georgina Island (CGIFN)		
<p>Was project information provided to the community?</p>	<p><input checked="" type="checkbox"/> Yes <input type="checkbox"/> No</p>	<p>Enbridge Gas has provided CGIFN with the following information:</p> <ul style="list-style-type: none"> • A detailed description of the nature and initial scope of the Project. This included a list of other provincial or federal approvals that may be required for the Project to proceed. • Maps of the Project location. • Letter containing information on the Virtual Open House. • Environmental Report, providing information about the potential effects of the Project on the Environment, including archaeological assessments. • Stage Two AA <p>Enbridge Gas requested community feedback, including any suggestions or proposals on mitigating, avoiding, or accommodating any potential impacts the Project may have on Aboriginal or treaty rights.</p>
<p>Was the community responsive/did you have direct contact with the community?</p>	<p><input checked="" type="checkbox"/> Yes <input type="checkbox"/> No</p>	<p>Enbridge Gas and an CGIFN representative have exchanged emails regarding the Project.</p>
<p>Did the community members or representatives have any questions or concerns?</p>	<p><input type="checkbox"/> Yes <input checked="" type="checkbox"/> No</p>	<p>CGIFN has not raised any questions or concerns regarding the Project and confirmed that they did not have any comments on the Stage 2 AA. CGIFN and Enbridge Gas had general discussions regarding the Project and ongoing engagement.</p>
<p>Does the community have any outstanding concerns?</p>	<p><input type="checkbox"/> Yes <input checked="" type="checkbox"/> No</p>	<p>As of April 13, 2023, CGIFN has not identified any outstanding concerns regarding the Project. Enbridge Gas will continue to engage with the community in relation to the Project.</p>

Chippewas of Rama First Nation (CRFN)		
<p>Was project information provided to the community?</p>	<p><input checked="" type="checkbox"/> Yes <input type="checkbox"/> No</p>	<p>Enbridge Gas has provided CRFN with the following information:</p> <ul style="list-style-type: none"> • A detailed description of the nature and initial scope of the Project. This included a list of other provincial or federal approvals that may be required for the Project to proceed. • Maps of the Project location. • Letter containing information on the Virtual Open House. • Environmental Report, providing information about the potential effects of the Project on the Environment, including archaeological assessments. • Stage Two AA <p>Enbridge Gas requested community feedback, including any suggestions or proposals on mitigating, avoiding or accommodating any potential impacts the Project may have on Aboriginal or treaty rights.</p>
<p>Was the community responsive/did you have direct contact with the community?</p>	<p><input checked="" type="checkbox"/> Yes <input type="checkbox"/> No</p>	<p>Enbridge Gas and a CRFN representative have exchanged emails regarding the Project. A CRFN representative advised the Enbridge Gas representative that they do not need to be involved in the process and will defer to MBQFN.</p>
<p>Did the community members or representatives have any questions or concerns?</p>	<p><input type="checkbox"/> Yes <input checked="" type="checkbox"/> No</p>	<p>On February 22, 2023, a CRFN representative advised that they had reviewed the Stage Two AA and saw that some ceramics had been uncovered, but there weren't any images of them. They asked whether MBQFN had been involved as monitors at any point during the Project and confirmed that they still did not have any concerns at this time regarding the Project. . CRFN and Enbridge Gas have had general discussions regarding the Project and ongoing engagement.</p>
<p>Does the community have any outstanding concerns?</p>	<p><input type="checkbox"/> Yes <input checked="" type="checkbox"/> No</p>	<p>As of April 13, 2023, CRFN has not identified any outstanding concerns regarding the Project. Enbridge Gas will continue to engage with the community in relation to the Project.</p>

Curve Lake First Nation (CLFN)		
<p>Was project information provided to the community?</p>	<p><input checked="" type="checkbox"/> Yes <input type="checkbox"/> No</p>	<p>Enbridge Gas has provided CLFN with the following information:</p> <ul style="list-style-type: none"> • A detailed description of the nature and initial scope of the Project. This included a list of other provincial or federal approvals that may be required for the Project to proceed. • Maps of the Project location. • Letter containing information on the Virtual Open House. • Environmental Report, providing information about the potential effects of the Project on the Environment, including archaeological assessments. • Stage Two AA <p>Enbridge Gas requested community feedback, including any suggestions or proposals on mitigating, avoiding or accommodating any potential impacts the Project may have on Aboriginal or treaty rights.</p> <p>Capacity funding has been offered to support activities such as timely technical reviews of documents, participation in field work associated with the proposed Project, and to engage in meaningful consultation.</p>
<p>Was the community responsive/did you have direct contact with the community?</p>	<p><input checked="" type="checkbox"/> Yes <input type="checkbox"/> No</p>	<p>Enbridge Gas and a CLFN representative have exchanged emails regarding the Project.</p>
<p>Did the community members or representatives have any questions or concerns?</p>	<p><input checked="" type="checkbox"/> Yes <input type="checkbox"/> No</p>	<p>CLFN inquired about potential Project impacts to drinking water, fish and wild game, Aboriginal heritage and cultural values, endangered species, and lands. CLFN inquired about the process in the event undocumented burial or archaeological resources were discovered, and general Project mitigation measures.</p>
<p>Does the community have any outstanding concerns?</p>	<p><input checked="" type="checkbox"/> Yes <input type="checkbox"/> No</p>	<p>As of April 13, 2023, CLFN has inquired about impacts to drinking water, fish and wild game, Aboriginal and cultural values, endangered species, and archeological resources if discovered, and general Project mitigation measures. Enbridge Gas will continue to engage with CLFN in relation to these interests and how any potential impacts will be addressed through the Project's mitigation measures.</p>

Hiawatha First Nation (HFN)		
<p>Was project information provided to the community?</p>	<p><input checked="" type="checkbox"/> Yes <input type="checkbox"/> No</p>	<p>Enbridge Gas has provided HFN with the following information:</p> <ul style="list-style-type: none"> • A detailed description of the nature and initial scope of the Project. This included a list of other provincial or federal approvals that may be required for the Project to proceed. • Maps of the Project location. • Letter containing information on the Virtual Open House. • Environmental Report, providing information about the potential effects of the Project on the Environment, including archaeological assessments. • Stage Two AA <p>Enbridge Gas requested community feedback, including any suggestions or proposals on mitigating, avoiding, or accommodating any potential impacts the Project may have on Aboriginal or treaty rights.</p>
<p>Was the community responsive/did you have direct contact with the community?</p>	<p><input checked="" type="checkbox"/> Yes <input type="checkbox"/> No</p>	<p>HFN and Enbridge Gas had general discussions regarding the Project and ongoing engagement. HFN advised Enbridge Gas that the consultants representing CLFN are representative of HFN's interests as well. HFN has raised concerns regarding the project.</p>
<p>Did the community members or representatives have any questions or concerns?</p>	<p><input checked="" type="checkbox"/> Yes <input type="checkbox"/> No</p>	<p>As of April 13, 2023, HFN has expressed concerns regarding the Project. HFN and Enbridge Gas had general discussions regarding the Project and ongoing engagement. On March 2, 2023, HFN provided comments on the Stage 1 AA and advised the historical section was not correct. HFN advised that the pre-contact historical section was incorrect, and the overall report lacked reference to the Anishinaabeg. HFN questioned why there is use of 'prefixes' such as 'ancestral' and noted this is problematic. HFN advised that the statements and assumptions made require further clarification and/or revision and that the main concern is the lack of information about the Anishinaabeg. HFN advised that the writers should seek new sources. HFN advised that they are intensely affected by the erasure and misrepresentation of their peoples' culture in the archaeological narrative in Ontario. HFN asked that Ontario archaeologists thoroughly explore evidence suggesting alternative explanations of societies and their history and not just settle on a single, convenient model.</p> <p>Enbridge Gas is currently working on responses to HFN's comments.</p>
<p>Does the community have any outstanding concerns?</p>	<p><input checked="" type="checkbox"/> Yes <input type="checkbox"/> No</p>	<p>As of April 13, 2023, HFN has identified concerns regarding the Project. Enbridge Gas is working on responses to these concerns and will continue to engage with the community in relation to the Project.</p>

Huron Wendat Nation (HWN)		
<p>Was project information provided to the community?</p>	<p><input checked="" type="checkbox"/> Yes <input type="checkbox"/> No</p>	<p>Enbridge Gas has provided HWN with the following information:</p> <ul style="list-style-type: none"> • A detailed description of the nature and initial scope of the Project. This included a list of other provincial or federal approvals that may be required for the Project to proceed. • Maps of the Project location. • Letter containing information on the Virtual Open House. • Environmental Report, providing information about the potential effects of the Project on the Environment, including archaeological assessments. • Stage Two AA <p>Enbridge Gas requested community feedback, including any suggestions or proposals on mitigating, avoiding, or accommodating any potential impacts the Project may have on Aboriginal or treaty rights.</p>
<p>Was the community responsive/did you have direct contact with the community?</p>	<p><input checked="" type="checkbox"/> Yes <input type="checkbox"/> No</p>	<p>HWN has not raised any specific questions or concerns regarding the Project. HWN had expressed an interest in participating in the Stage 2 archaeological assessment, but subsequently decided not to participate. HWN and Enbridge Gas had general discussions regarding the Project and ongoing engagement.</p>
<p>Did the community members or representatives have any questions or concerns?</p>	<p><input type="checkbox"/> Yes <input checked="" type="checkbox"/> No</p>	<p>HWN has not raised any questions or concerns regarding the Project. On March 8, 2023, an HWN representative advised the Enbridge Gas representative that they did not have any comments on the Project. HWN and Enbridge Gas had general discussions regarding the Project and ongoing engagement.</p>
<p>Does the community have any outstanding concerns?</p>	<p><input type="checkbox"/> Yes <input checked="" type="checkbox"/> No</p>	<p>As of April 13, 2023, HWN has not identified any outstanding concerns regarding the Project. Enbridge Gas will continue to engage with the community in relation to the Project.</p>

Kawartha Nishnawbe First Nation (KNFN)		
<p>Was project information provided to the community?</p>	<p><input checked="" type="checkbox"/> Yes <input type="checkbox"/> No</p>	<p>Enbridge Gas has provided KNFN Nation with the following information:</p> <ul style="list-style-type: none"> • A detailed description of the nature and initial scope of the Project. This included a list of other provincial or federal approvals that may be required for the Project to proceed. • Maps of the Project location. • Letter containing information on the Virtual Open House. • Environmental Report, providing information about the potential effects of the Project on the Environment, including archaeological assessments. • Stage Two AA <p>Enbridge Gas requested community feedback, including any suggestions or proposals on mitigating, avoiding, or accommodating any potential impacts the Project may have on Aboriginal or treaty rights.</p>
<p>Was the community responsive/did you have direct contact with the community?</p>	<p><input type="checkbox"/> Yes <input checked="" type="checkbox"/> No</p>	<p>To date, KNFN has not raised any questions or concerns regarding the Project.</p>
<p>Did the community members or representatives have any questions or concerns?</p>	<p><input type="checkbox"/> Yes <input checked="" type="checkbox"/> No</p>	<p>KNFN has not raised any questions or concerns regarding the Project. KNFN and Enbridge Gas had general discussions regarding the Project and ongoing engagement.</p>
<p>Does the community have any outstanding concerns?</p>	<p><input type="checkbox"/> Yes <input checked="" type="checkbox"/> No</p>	<p>As of April 13, 2023, KNFN has not identified any outstanding concerns regarding the Project. Enbridge Gas will continue to engage with the community in relation to the Project.</p>

Mississauga's of Scugog Island First Nation (MSIFN)		
<p>Was project information provided to the community?</p>	<p><input checked="" type="checkbox"/> Yes <input type="checkbox"/> No</p>	<p>Enbridge Gas has provided MSIFN Nation with the following information:</p> <ul style="list-style-type: none"> • A detailed description of the nature and initial scope of the Project. This included a list of other provincial or federal approvals that may be required for the Project to proceed. • Maps of the Project location. • Letter containing information on the Virtual Open House. • Environmental Report, providing information about the potential effects of the Project on the Environment, including archaeological assessments. • Stage Two AA <p>Enbridge Gas requested community feedback, including any suggestions or proposals on mitigating, avoiding or accommodating any potential impacts the Project may have on Aboriginal or treaty rights.</p>
<p>Was the community responsive/did you have direct contact with the community?</p>	<p><input checked="" type="checkbox"/> Yes <input type="checkbox"/> No</p>	<p>MSIFN has not raised any questions or concerns regarding the Project. MSIFN and Enbridge Gas had general discussions regarding the Project and ongoing engagement.</p>
<p>Did the community members or representatives have any questions or concerns?</p>	<p><input type="checkbox"/> Yes <input checked="" type="checkbox"/> No</p>	<p>MSIFN has not raised any specific questions or concerns regarding the Project. MSIFN and Enbridge Gas had general discussions regarding the Project and ongoing engagement and MSIFN expressed an interest in seeing the results of the studies, which Enbridge Gas committed to providing. On January 16, 2023, an MSIFN representative advised the Enbridge Gas representative that that given there was no archaeological material identified during the assessment, they did not have any further concerns at this point given the archaeological potential for the Project. MSIFN asked to be informed if anything were to change.</p>
<p>Does the community have any outstanding concerns?</p>	<p><input type="checkbox"/> Yes <input checked="" type="checkbox"/> No</p>	<p>As of April 13, 2023, MSIFN has not identified any outstanding concerns regarding the Project. Enbridge Gas will continue to engage with the community in relation to the Project.</p>

Mohawks of the Bay of Quinte (MBQFN)		
<p>Was project information provided to the community?</p>	<p><input checked="" type="checkbox"/> Yes <input type="checkbox"/> No</p>	<p>Enbridge Gas has provided MBQFN with the following information:</p> <ul style="list-style-type: none"> • A detailed description of the nature and initial scope of the Project. This included a list of other provincial or federal approvals that may be required for the Project to proceed. • Maps of the Project location. • Letter containing information on the Virtual Open House. • Environmental Report, providing information about the potential effects of the Project on the Environment, including archaeological assessments. • Stage Two AA <p>Enbridge Gas requested community feedback, including any suggestions or proposals on mitigating, avoiding or accommodating any potential impacts the Project may have on Aboriginal or treaty rights.</p> <p>Capacity funding has been offered to support activities such as timely technical reviews of documents, participation in field work associated with the proposed Project, and to engage in meaningful consultation.</p>
<p>Was the community responsive/did you have direct contact with the community?</p>	<p><input checked="" type="checkbox"/> Yes <input type="checkbox"/> No</p>	<p>Enbridge Gas and MBQFN representatives have met multiple times including virtual/in-person meetings on September 1, 2021, November 30, 2021, January 27, 2022, June 8, 2022, November 22, 2022, December 15, 2022, March 2nd and March 21, 2023 to discuss the Project.</p> <p>On August 9, 2022, MBQFN provided comments on the Environmental Report. On August 24, 2022, Enbridge Gas responded to MBQFN's comments on the Environmental Report.</p>
<p>Did the community members or representatives have any questions or concerns?</p>	<p><input checked="" type="checkbox"/> Yes <input type="checkbox"/> No</p>	<p>As of April 13, 2023, MBQFN has expressed concerns about nitrogen and hydrostatic testing, vegetation, re-establishment monitoring, reclamation, and contamination protocol. MBQFN has also inquired about the feasibility of avoiding the use of open cuts in the construction process and aligning work with the community's infrastructure plans, advised of sensitivities around the mud creek on slash road and the Salmon River, training and economic/business opportunities, requested a community monitor be present for archaeological work, that they be contacted for any species-at-risk, wildlife or spills encountered in the construction area and to receive future protocols and schedules for review prior to commencement of the work. Enbridge Gas provided MBQFN with responses to these comments.¹ Enbridge Gas will continue to engage with the community in relation to the Project.</p>

¹ Exhibit H-1-1, Attachment 6, Line Item 10.73

Does the community have any outstanding concerns?	<input type="checkbox"/> Yes <input checked="" type="checkbox"/> No	As of April 13, 2023, MBQFN has not identified any outstanding concerns regarding the Project though Enbridge Gas and MBQFN still need to confirm the land requirements for the Project on reserve. Enbridge Gas provided information regarding the section 28.2 permit and the extension requirement for the Project. Enbridge Gas will continue to engage with the community in relation to the Project.
--	--	--

Enbridge Gas Inc. Indigenous Engagement Log
Mohawks of the Bay of Quinte Community Expansion Project

Log updated as of April 13, 2023

Alderville First Nation (AFN)					
Line Item	Date	Method	Summary of Enbridge Gas Inc. ("Enbridge Gas") Engagement Activity	Summary of Community's Engagement Activity	Issues or Concerns raised and how addressed by Enbridge Gas including attachments
1.13	January 9, 2023	Email	An Enbridge Gas representative emailed the AFN representative to provide them with the Stage 2 Archaeological Assessment ("AA") report pertaining to the Project. Enbridge Gas representative asked if comments could be received by February 15, 2023. The Enbridge Gas representative noted that Enbridge Gas would be interested in any feedback.		
1.14	January 16, 2023	Email	An Enbridge Gas representative emailed the AFN representative to provide them with the Stage 1 – 2 AA for the laydown area pertaining to the Project. The Enbridge Gas representative noted that Enbridge Gas would be interested in any feedback.		
1.15	February 15, 2023	Email	An Enbridge Gas representative emailed the AFN representative to follow up regarding the Stage 2 AA report pertaining to the Project and asked whether AFN had the chance to comment on the report. The Enbridge Gas representative noted that Enbridge Gas would be interested in any feedback.		
Beausoleil First Nation (BFN)					
Line Item	Date	Method	Summary of Enbridge Gas Inc. ("Enbridge Gas") Engagement Activity	Summary of Community's Engagement Activity	Issues or Concerns raised and how addressed by Enbridge Gas including attachments
2.11	January 9, 2023	Email	An Enbridge Gas representative emailed the BFN representative to provide them with the Stage		

			2 AA report pertaining to the Project. Enbridge Gas representative asked if comments could be received by February 15, 2023. The Enbridge Gas representative noted that Enbridge Gas would be interested in any feedback.		
2.12	January 16, 2023	Email	An Enbridge Gas representative emailed the BFN representative to provide them with the Stage 1 – 2 AA for the laydown area pertaining to the Project. The Enbridge Gas representative noted that Enbridge Gas would be interested in any feedback.		
2.13	February 15, 2023	Email	An Enbridge Gas representative emailed the BFN representative to follow up regarding the Stage 2 AA report pertaining to the Project and asked whether BFN had the chance to comment on the report. The Enbridge Gas representative noted that Enbridge Gas would be interested in any feedback.		

Chippewas of Georgina Island (CGIFN)

Line Item	Date	Method	Summary of Enbridge Gas Inc. (“Enbridge Gas”) Engagement Activity	Summary of Community’s Engagement Activity	Issues or Concerns raised and how addressed by Enbridge Gas including attachments
3.12	January 9, 2023	Email	An Enbridge Gas representative emailed the CGIFN representative to provide them with the Stage 2 AA report pertaining to the Project. Enbridge Gas representative asked if comments could be received by February 15, 2023. The Enbridge Gas representative noted that Enbridge Gas would be interested in any feedback.		
3.13	January 16, 2023	Email	An Enbridge Gas representative emailed the CGIFN representative to provide them with the Stage 1 – 2 AA for the laydown area pertaining to the Project. The Enbridge Gas representative		

			noted that Enbridge Gas would be interested in any feedback.		
3.14	February 15, 2023	Email	An Enbridge Gas representative emailed the CGIFN representative to follow up regarding the Stage 2 AA report pertaining to the Project and asked whether CGIFN had the chance to comment on the report. The Enbridge Gas representative noted that Enbridge Gas would be interested in any feedback.		
3.15	February 16, 2023	Email		A CGIFN representative emailed the Enbridge Gas representative to advise they had no comments on the Stage 2 AA report.	
3.16	February 16, 2023	Email	An Enbridge Gas representative emailed the CGIFN representative to confirm receipt of the email. The Enbridge Gas representative requested a phone call with the CGIFN representative to discuss ongoing Enbridge Gas Projects.		
Chippewas of Rama First Nation (CRFN)					
Line Item	Date	Method	Summary of Enbridge Gas Inc. ("Enbridge Gas") Engagement Activity	Summary of Community's Engagement Activity	Issues or Concerns raised and how addressed by Enbridge Gas including attachments
4.11	January 9, 2023	Email	An Enbridge Gas representative emailed the CRFN representative to provide them with the Stage 2 AA report pertaining to the Project. Enbridge Gas representative asked if comments could be received by February 15, 2023. The Enbridge Gas representative noted that Enbridge Gas would be interested in any feedback.		
4.12	January 16, 2023	Email	An Enbridge Gas representative emailed the CRFN representative to provide them with the Stage 1 – 2 AA for the laydown area pertaining to the Project. The Enbridge Gas representative noted that Enbridge Gas		

			would be interested in any feedback.		
4.13	February 16, 2023	Email	An Enbridge Gas representative emailed the CRFN representative to follow up regarding the Stage 2 AA report pertaining to the Project and asked whether CRFN had the chance to comment on the report. The Enbridge Gas representative noted that Enbridge Gas would be interested in any feedback.		
4.14	February 22, 2023	Email		A CRFN representative emailed the Enbridge Gas representative to advise that they have looked over the reports and advised that they saw that some ceramics had been uncovered, but there weren't any images of them. They asked whether MBQFN had been involved as monitors at any point during the Project. The CRFN representative advised that they still had no concerns at this time regarding the Project.	
4.15	February 22, 2023	Email	An Enbridge Gas representative emailed the CRFN representative to confirm that they did have pictures of the ceramics and that they could be provided to them. The Enbridge Gas representative advised that MBQFN has been heavily involved in the Project and that they had monitors participating in work for the Project.		
Curve Lake First Nation (CLFN)					
Line Item	Date	Method	Summary of Enbridge Gas Inc. ("Enbridge Gas") Engagement Activity	Summary of Community's Engagement Activity	Issues or Concerns raised and how addressed by Enbridge Gas including attachments
5.16	January 9, 2023	Email	An Enbridge Gas representative emailed the CLFN representative to provide them with the Stage 2 AA report pertaining to the Project. Enbridge Gas representative asked if comments could be received		

			by February 15, 2023. The Enbridge Gas representative noted they would be interested in any feedback.		
5.17	January 16, 2023	Email	An Enbridge Gas representative emailed the CLFN representative to provide them with the Stage 1 – 2 AA for the laydown area pertaining to the Project. The Enbridge Gas representative noted that Enbridge Gas would be interested in any feedback.		
5.18	February 16, 2023	Email	An Enbridge Gas representative emailed the CLFN representative to follow up regarding the Stage 2 AA report pertaining to the Project and asked whether CLFN had the chance to comment on the report. The Enbridge Gas representative noted that Enbridge Gas would be interested in any feedback.		
Hiawatha First Nation (HFN)					
Line Item	Date	Method	Summary of Enbridge Gas Inc. (“Enbridge Gas”) Engagement Activity	Summary of Community’s Engagement Activity	Issues or Concerns raised and how addressed by Enbridge Gas including attachments
6.12	January 9, 2023	Email	An Enbridge Gas representative emailed the HFN representative to provide them with the Stage 2 AA report pertaining to the Project. Enbridge Gas representative asked if comments could be received by February 15, 2023. The Enbridge Gas representative noted they would be interested in any feedback.		
6.13	January 16, 2023	Email	An Enbridge Gas representative emailed the HFN representative to provide them with the Stage 1 – 2 AA for the laydown area pertaining to the Project. The Enbridge Gas representative noted that Enbridge Gas would be interested in any feedback.		
6.14	February 15, 2023	Email	An Enbridge Gas representative emailed the HFN representative to follow		

			up regarding the Stage 1 AA report pertaining to the Project and asked whether HFN had the chance to comment on the report. The Enbridge Gas representative noted that they would be interested in any feedback.		
6.15	February 16, 2023	Email		A HFN representative emailed the Enbridge Gas representative to advise that they are working on responses to the Stage 2 AA report.	
6.16	February 22, 2023	Email	An Enbridge Gas representative emailed the HFN representative to confirm receipt of email and that HFN is working on Stage 2 AA responses.		
6.17	March 2, 2023	Email		An HFN representative emailed the Enbridge Gas representative to provide comments on the Stage 1 AA.	<p>An HFN representative emailed the Enbridge Gas representative a review of the Stage 1 AA for the Project. The HFN representative acknowledged that they agreed with the methodology and recommendations in the report, but advised that the historical section was not correct.</p> <p>HFN questioned the focus of the HWN throughout the report, especially in the pre-contact and historical section, and mentioned the only reference to the Anishinaabeg is in the 'Land Acknowledgement.' The HFN representative advised that the history being recounted in this report is not only incorrect but excludes the</p>

					<p>Anishinaabeg and their connection to these lands.</p> <p>Among other things, HFN advised that the report should be more inclusive of people who were here before, during and after the HWN came and then moved on.</p> <p>HFN advised that the main concern is the lack of information about the Anishinaabeg.</p> <p>HFN asked that they thoroughly explore evidence suggesting alternative explanations of societies and their history.</p> <p>HFN advised that they have been in touch with MBQ about their concerns, to inquire about any concerns they had before signing off on the report. HFN advised after their discussions with MBQ, they are also unhappy with the historical portrayal.</p> <p>Enbridge Gas representative is working on responses to these comments.</p>
6.18	March 3, 2023	Email	An Enbridge Gas representative emailed the HFN representative to advise that they have received their comments on the report and that they were working on responses.		
Huron-Wendat Nation (HWN)					

Line Item	Date	Method	Summary of Enbridge Gas Inc. (“Enbridge Gas”) Engagement Activity	Summary of Community’s Engagement Activity	Issues or Concerns raised and how addressed by Enbridge Gas including any attachments
7.10	January 9, 2023	Email	An Enbridge Gas representative emailed the HWN representative to provide them with the Stage 2 AA report pertaining to the Project. Enbridge Gas representative asked if comments could be received by February 15, 2023. The Enbridge Gas representative noted that Enbridge Gas would be interested in any feedback.		
7.11	January 16, 2023	Email	An Enbridge Gas representative emailed the HWN representative to provide them with the Stage 1 – 2 AA for the laydown area pertaining to the Project. The Enbridge Gas representative noted that Enbridge Gas would be interested in any feedback.		
7.12	February 15, 2023	Email	An Enbridge Gas representative emailed the HWN representative to follow up regarding the Stage 2 AA report pertaining to the Project and asked whether HWN had the chance to comment on the report. The Enbridge Gas representative noted that they would be interested in any feedback.		
7.13	March 8, 2023	Email		A HWN representative emailed the Enbridge Gas representative to advise they had no comments on the Project.	
7.14	March 17, 2023	Email	An Enbridge Gas representative emailed the HWN representative to advise they received their email and would continue to provide updates on the Project.		
Kawartha Nishnawbe First Nation (KNFN)					
Line Item	Date	Method	Summary of Enbridge Gas Inc. (“Enbridge Gas”) Engagement Activity	Summary of Community’s Engagement Activity	Issues or Concerns raised and how addressed by Enbridge Gas

					including attachments
8.8	January 9, 2023	Email	An Enbridge Gas representative emailed the KNFN representative to provide them with the Stage 2 AA report pertaining to the Project. Enbridge Gas representative asked if comments could be received by February 15, 2023. The Enbridge Gas representative noted that Enbridge Gas would be interested in any feedback.		
8.9	January 16, 2023	Email	An Enbridge Gas representative emailed the KNFN representative to provide them with the Stage 1 – 2 AA for the laydown area pertaining to the Project. The Enbridge Gas representative noted that Enbridge Gas would be interested in any feedback.		
8.10	February 15, 2023	Email	An Enbridge Gas representative emailed the KNFN representative to follow up regarding the Stage 2 AA report pertaining to the Project and asked whether KNFN had the chance to comment on the report. The Enbridge Gas representative noted that they would be interested in any feedback.		
Mississaugas of Scugog Island First Nation (MSIFN)					
Line Item	Date	Method	Summary of Enbridge Gas Inc. (“Enbridge Gas”) Engagement Activity	Summary of Community’s Engagement Activity	Issues or Concerns raised and how addressed by Enbridge Gas including attachments
9.17	January 9, 2023	Email	An Enbridge Gas representative emailed the MSIFN representative to provide them with the Stage 2 AA report pertaining to the Project. Enbridge Gas representative asked if comments could be received by February 15, 2023. The Enbridge Gas representative noted that Enbridge Gas would be interested in any feedback.		
9.18	January 16, 2023	Email	An Enbridge Gas representative emailed the		

			MSIFN representative to provide them with the Stage 1 – 2 AA for the laydown area pertaining to the Project. The Enbridge Gas representative noted that they would be interested in any feedback.		
9.19	January 16, 2023	Email		An MSIFN representative emailed the Enbridge Gas representative to advise that given there was no archeological material identified during the assessment, that MSIFN has no further concerns at this point regarding the archeological potential for the Project. MSIFN advised that they would like to be informed if anything were to change.	
9.20	January 16, 2023	Email	An Enbridge Gas representative emailed the MSIFN representative to confirm receipt of the email and that they will continue to provide MSIFN with any Project information as it becomes available.		
9.21	February 15, 2023	Email	An Enbridge Gas representative emailed the MSIFN representative to follow up regarding the Stage 2 AA report pertaining to the Project and asked whether MSIFN had the chance to comment on the report. The Enbridge Gas representative noted that they would be interested in any feedback.		
Mohawks of the Bay of Quinte (MBQFN)					
Line Item	Date	Method	Summary of Enbridge Gas Inc. (“Enbridge Gas”) Engagement Activity	Summary of Community’s Engagement Activity	Issues or Concerns raised and how addressed by Enbridge Gas including attachments
10.92	January 9, 2023	Email	An Enbridge Gas representative emailed the MBQFN representative to provide them with the Stage 2 AA report pertaining to the Project. Enbridge Gas representative asked if comments could be received by February 15, 2023. The Enbridge Gas representative		

			noted that they would be interested in any feedback.		
10.93	January 16, 2023	Email	An Enbridge Gas representative emailed the MBQFN representative to provide them with the Stage 1 – 2 AA for the laydown area pertaining to the Project. The Enbridge Gas representative noted that they would be interested in any feedback.		
10.94	February 15, 2023	Email	An Enbridge Gas representative emailed the MBQFN representative to follow up regarding the Stage 2 AA report pertaining to the Project and asked whether MBQFN had the chance to comment on the report. The Enbridge Gas representative noted that they would be interested in any feedback.		
10.95	March 2, 2023		An Enbridge Gas representative and MBQFN representatives to discuss the concerns with the Stage 2 AA. Enbridge Gas and MBQFN discussed concerns surrounding the historical context of these report and the 19th and 20 th century settlement in the area.		
10.96	March 21, 2023	In-person meeting	An Enbridge Gas representative and MBQFN representatives had a meeting in person to discuss various property line issues concerning the Project and the ability to survey those areas. Enbridge Gas and MBQFN representatives discussed the extension of the 28.2 permit. Enbridge Gas and MBQFN representatives discussed MBQFN providing comments in writing on the Stage 2 AA.	MBQFN provided comments orally about the Stage 2 AA and advised they would provide them in writing as well.	MBQFN advised the Enbridge Gas representative that they would provide written comments on the Stage 2 AA.
10.97	March 23, 2023	Email	An Enbridge Gas representative emailed the MBQFN representative to follow up on their meeting. The Enbridge Gas representative wanted to follow up regarding property lines concerning the Project and the ability to survey		

			<p>those areas in question. The Enbridge Gas representative reminded the MBQFN representatives to provide Enbridge Gas with the BCR related to the section 28.2 permit.</p> <p>The Enbridge Gas representative advised that they will put together notices to both MBQFN and Indigenous Services Canada pursuant to the section 28.2 permit. The Enbridge Gas representative also advised that they are looking forward to the customer attachment kiosk/dinner and asked if MBQFN had any recommended caterers. The Enbridge Gas representative also asked MBQFN when they could provide their comments on the Stage 2 AA.</p>		
10.98	March 24, 2023	Email		An MBQFN representative emailed the Enbridge Gas representative to provide them a list of caterers in the Community.	
10.99	March 24, 2023	Email	An Enbridge Gas representative emailed MBQFN representatives to thank them for the list of caterers.		
10.100	April 3, 2023	Email / Notice	An Enbridge Gas representative emailed MBQFN representatives to provide them a Notice to advise them about the process regarding the section 28.2 permit. The Enbridge Gas representative advised that pursuant to the existing permit with MBQFN, they are seeking MBQFN's consent before the proposed extension order to accommodate additional assets planned for the Project.		<p>Enbridge Gas provided MBQFN a notice regarding the extension for the 28.2 permit.</p> <p>MBQFN is confirming whether the extension is required.</p>
10.101	April 4, 2023	Email	An Enbridge Gas representative emailed the MBQFN representative to ask if they had completed their comments on the Project's Stage 2 AA.		
10.102	April 12, 2023	Email		An MBQFN representative emailed the Enbridge Gas to	

				advise that at Enbridge's request they have booked the caterer for the customer attachment kiosk. The MBQFN representative provided the possible menu and advised they will provide a quote shortly.	
10.103	April 13, 2023	Email	An Enbridge Gas representative emailed the MBQFN representative to advise that there were severe allergies regarding the catering for the customer attachment kiosk.		

From: Brown, Gillian (ENERGY) <Gillian.Brown2@ontario.ca>
Sent: Friday, February 3, 2023 1:42:26 PM
To: Melanie Green <Melanie.Green@enbridge.com>
Cc: consultation@ramafirstnation.ca <consultation@ramafirstnation.ca>; Gaboury, Bree-Anna (ENERGY) <Bree-Anna.Gaboury@ontario.ca>
Subject: [External] Introductions re: Mohawks of the Bay of Quinte Community Expansion Project (Enbridge)

CAUTION! EXTERNAL SENDER

Were you expecting this email? TAKE A CLOSER LOOK. Is the sender legitimate?
DO NOT click links or open attachments unless you are 100% sure that the email is safe.

Hi Melanie,

I hope you're having a lovely day.

I would like to introduce you to Ben Benson, who is the new Community Consultation Worker at Chippewas of Rama First Nation. I had the pleasure of reaching out to Ben as part of the Ministry of Energy's work on the letter of opinion for Enbridge's Mohawks of the Bay of Quinte Community Expansion Project. Ben shared he is new to the role and not familiar with the community's experience on the project but would appreciate a meeting to learn about it and build that relationship with Enbridge.

Would you be able to set up a meeting with Ben to discuss the project and any other relevant projects?

Ben - Myself and Bree at the Ministry of Energy look forward to meeting with you to build our own relationship, and I can follow up by email once you and Melanie have had a chance to meet.

All the best,
Gillian

Gillian Brown
Senior Advisor
Indigenous Energy Policy
Ministry of Energy

From: Melanie Green <Melanie.Green@enbridge.com>
Sent: 03 February 2023 14:21
To: Brown, Gillian (ENERGY) <Gillian.Brown2@ontario.ca>
Cc: consultation@ramafirstnation.ca <consultation@ramafirstnation.ca>; Gaboury, Bree-Anna (ENERGY) <Bree-Anna.Gaboury@ontario.ca>; Lauryn Graham <lauryn.graham@enbridge.com>
Subject: Re: Introductions re: Mohawks of the Bay of Quinte Community Expansion Project (Enbridge)

CAUTION -- EXTERNAL E-MAIL - Do not click links or open attachments unless you recognize the sender.

Hello and thank you so much for your email and information. I would absolutely be able to brief Ben on the project. I have actually chatted with Ben, we have began building our relationship and will meet in person at Chippewas Of Rama on Monday the 6th of February. I look forward to meeting Ben and the rest of the team.

Again, thank you much and I really look forward to meeting you all in person too.

Mel

Get [Outlook for iOS](#)

From: Brown, Gillian (ENERGY) <Gillian.Brown2@ontario.ca>
Sent: Friday, February 3, 2023 2:39 PM
To: Melanie Green <Melanie.Green@enbridge.com>
Cc: consultation@ramafirstnation.ca; Gaboury, Bree-Anna (ENERGY) <Bree-Anna.Gaboury@ontario.ca>; Lauryn Graham <lauryn.graham@enbridge.com>
Subject: [External] Re: Introductions re: Mohawks of the Bay of Quinte Community Expansion Project (Enbridge)

CAUTION! EXTERNAL SENDER

Were you expecting this email? TAKE A CLOSER LOOK. Is the sender legitimate?
DO NOT click links or open attachments unless you are 100% sure that the email is safe.

Hi Melanie,

That's wonderful to hear. Thanks very much for your quick reply.

I hope everyone has a lovely meeting on the 6th.

Best,
Gillian

From: Melanie Green <Melanie.Green@enbridge.com>
Sent: 09 February 2023 11:21
To: Brown, Gillian (ENERGY) <Gillian.Brown2@ontario.ca>
Cc: Gaboury, Bree-Anna (ENERGY) <Bree-Anna.Gaboury@ontario.ca>; Lauryn Graham <lauryn.graham@enbridge.com>
Subject: RE: Introductions re: Mohawks of the Bay of Quinte Community Expansion Project (Enbridge)

CAUTION -- EXTERNAL E-MAIL - Do not click links or open attachments unless you recognize the sender.

Good morning,

Just circling back here – we had a nice visit with Ben and Samantha at Chippewas of Rama First Nation. They are lovely and we look forward to working together more closely in future. We did chat about projects (among other things) as I know that Ben is new, so we brought him up to speed and he is aware if he has any questions or is interested in a project briefing to let us know and we would be happy to gather the team to provide as much information as required.

Thank you again and I hope to meet you soon too 😊

Mel

From: Brown, Gillian (ENERGY) <Gillian.Brown2@ontario.ca>
Sent: Thursday, February 9, 2023 1:06 PM
To: Melanie Green
Cc: Gaboury, Bree-Anna (ENERGY); Lauryn Graham
Subject: [External] Re: Introductions re: Mohawks of the Bay of Quinte Community Expansion Project (Enbridge)

CAUTION! EXTERNAL SENDER

Were you expecting this email? TAKE A CLOSER LOOK. Is the sender legitimate?
DO NOT click links or open attachments unless you are 100% sure that the email is safe.

Hi Melanie,

Thanks very much for following up.

I'm happy to hear that the meeting with Ben and Samantha went well and that he knows your team is there as a resource to provide further information if required.

I agree, us meeting as well in the future would be lovely. Until then, take care and talk soon.

Best,
Gillian

From: Melanie Green <Melanie.Green@enbridge.com>
Sent: April 4, 2023 10:15 AM
To: Brown, Gillian (ENERGY) <Gillian.Brown2@ontario.ca>
Subject: MBQ - update

CAUTION -- EXTERNAL E-MAIL - Do not click links or open attachments unless you recognize the sender.

Good morning Gillian,

I hope your day is going nice – the weather is finally nice and were able to get out for walks. I am just touching base on the status of your opinion related to the Mohawks of the Bay Of Quinte Community Expansion Project. I know you're probably swamped so I thought I would check in.

No stress and have a good day!

Chat soon!

Mel

From: Brown, Gillian (ENERGY) <Gillian.Brown2@ontario.ca>
Sent: Tuesday, April 4, 2023 2:01 PM
To: Melanie Green <Melanie.Green@enbridge.com>
Subject: [External] RE: MBQ - update

CAUTION! EXTERNAL SENDER

Were you expecting this email? TAKE A CLOSER LOOK. Is the sender legitimate?

DO NOT click links or open attachments unless you are 100% sure that the email is safe.

Hi Melanie,

Glad you've been able to get outside and enjoy some of the spring weather.

Our work on the letter of opinion for the Mohawks of the Bay of Quinte Community Expansion Project continues. We meet with the Mohawks of the Bay of Quinte First Nation next week to hear their thoughts on consultation to-date, and continue to review any relevant materials at the OEB process.

As part of our process, we will be reviewing Enbridge's written responses to all interrogatories, which are due to be served by April 25, 2023. Our goal is to deliver the letter to Enbridge in the following days immediately after, likely by April 28th at the latest.

I will make sure to also inform Zora at the OEB of our planned timing.

Ministry of Energy

Ministère de l'Énergie

Energy Networks and Indigenous Policy
Branch

Direction Générale des Réseaux Énergétiques
et des Politiques Autochtones



Indigenous Energy Policy

Politique Énergétique Autochtones

77 Grenville Street, 6th Floor
Toronto, ON M7A 67C
Tel: (416) 315-8641

77 Rue Grenville, 6^e Étage
Toronto, ON M7A 67C
Tel: (416) 315-8641

April 25, 2023

VIA EMAIL

Adam Stiers
Manager, Regulatory Applications – Leave to Construct
Regulatory Affairs
Enbridge Gas Incorporated
50 Keil Drive North,
Chatham, ON N7M 5M1

Re: Letter of Opinion – Mohawks of the Bay of Quinte Community Expansion Project

Dear Mr. Stiers,

The Ontario Ministry of Energy (ENERGY) has completed its review of the consultation undertaken by Enbridge Gas Inc. (Enbridge) with Indigenous communities for the Mohawks of the Bay of Quinte Community Expansion Project (the Project).

ENERGY has reviewed the information provided by Enbridge as well as materials filed with the Ontario Energy Board (OEB), which included materials filed by Mohawks of the Bay of Quinte First Nation in their role as intervenor. ENERGY met directly with this community and heard firsthand that it supports the project and Enbridge's consultation efforts to-date.

ENERGY also engaged with Indigenous communities to understand any concerns about potential impacts to Aboriginal and treaty rights from the project as well as community feedback about satisfaction with Enbridge's response or proposed mitigation, where appropriate.

This letter is to notify you that, based on this review of materials and our outreach to Indigenous communities, ENERGY is of the opinion that the procedural aspects of consultation undertaken by Enbridge to-date for the purposes of the Ontario Energy Board's Leave to Construct for the Project are satisfactory.

It is expected that Enbridge will continue its consultation activities with the Indigenous communities throughout the life of the project, and that Enbridge will notify ENERGY should any rights-based concerns/issues arise.

If you have any questions about this letter or require any additional information, please contact me at 416-315-8641 or amy.gibson@ontario.ca.

Sincerely,

A handwritten signature in black ink that reads "Amy Gibson". The signature is written in a cursive style with a long, sweeping underline.

Amy Gibson, Manager
Indigenous Energy Policy, Ontario Ministry of Energy

c: Ontario Energy Board
Ontario Pipeline Coordinating Committee

ENBRIDGE GAS INC.

Answer to Interrogatory from
Environmental Defence (“ED”)

INTERROGATORY

Reference:

Exhibit B, Tab 1, Schedule 1, Page 5-7

Question(s):

- (a) Please reproduce Figure 1, Figure 2, and Table 1 adding a separate column for heating with electric air source heat pumps. Please provide a table listing all the calculations and assumptions underlying the cost estimate for electric air source heat pumps.
- (b) Please provide all the underlying calculations and assumptions underlying Figure 1, Figure 2, and Table 1, including the underlying spreadsheet with live formulas. Please include all assumptions, including, but not limited to, the assumed price on carbon.
- (c) If an excel spreadsheet is used to assess the relative cost-effectiveness of the various heating options, please provide that live excel spreadsheet with the variables set consistent with output in Figure 1. A model that Enbridge used in the past can be found at EB-2019-0188, Exhibit I.ED.7, Attachment 1, but we do not have a version that has been updated and set with the variables used in this case.

Response

- (a) Please see the response at EB-2022-0249 Exhibit I.ED.1, part (a).
- (b) – (c)
Please see Attachments 1 and 2 to this response for all the underlying calculations and assumptions for Table 1 and Figures 1 and 2.

While preparing a response to this interrogatory, Enbridge Gas noted a typographical error in Exhibit B, Tab 1, Schedule 1, p. 7, Table 1, whereby the

Annual Bill for Natural Gas set out in that table is incorrectly noted as \$2,243. The correct figure is set out at Exhibit B, Tab 1, Schedule 1, pp. 5-6, Figures 1 and 2 and in Attachment 1 to this response, as \$2,174. This error was typographical only within Table 1. All Annual Natural Gas Saving with SES (\$) calculations in Table 1 were calculated correctly using \$2,174.

Attachment 2 provides two scenarios of the Annual Energy Price Comparison for a typical residential customer living in the Rate 01 Union Northeast rate zone, in live Excel spreadsheet format, as requested. Figure 1 in Attachment 2 provides the energy comparison including the system expansion surcharge ("SES"). Figure 2 in Attachment 2 provides the energy comparison including SES but it also excludes distribution charges per the First Nations Delivery Credit. The model referenced by ED in the interrogatory was not used in relation to this Project or Application.

Additionally, Attachment 3 to this response provides Figure 1 and Figure 2 updated based on natural gas rates that came into effect as of April 1, 2023. Rates for all other fuel types continue to be based on best available information at the time of comparison (January 2023 for heating oil, February 2023 for propane, and January 2023 and winter Time-of-Use ("TOU") for electricity).

	Penetration Rate ^[1]	Annual Space & Water Heating Bills ^[2]	Annual Natural Gas Saving with SES
Natural Gas	-	\$ 2,174.00	-
Heating Oil	32%	\$ 5,108.00	\$ 2,934.00
Electricity	4%	\$ 2,127.00	\$ (47.00)
Propane	56%	\$ 2,478.00	\$ 304.00
Wood	9%	No data available	No data available
Weighted Average			\$ 1,107.24

[1] Exhibit B, Tab 1, Schedule 1, Attachment 4: Question 5 results

[2] Exhibit I.ED.1_Attachment 2, Worksheets for First Nations Communities: Figure 2, Price Comparison Table 2

Figure 1: Annual Energy Costs & Savings Versus Natural Gas, Including SES

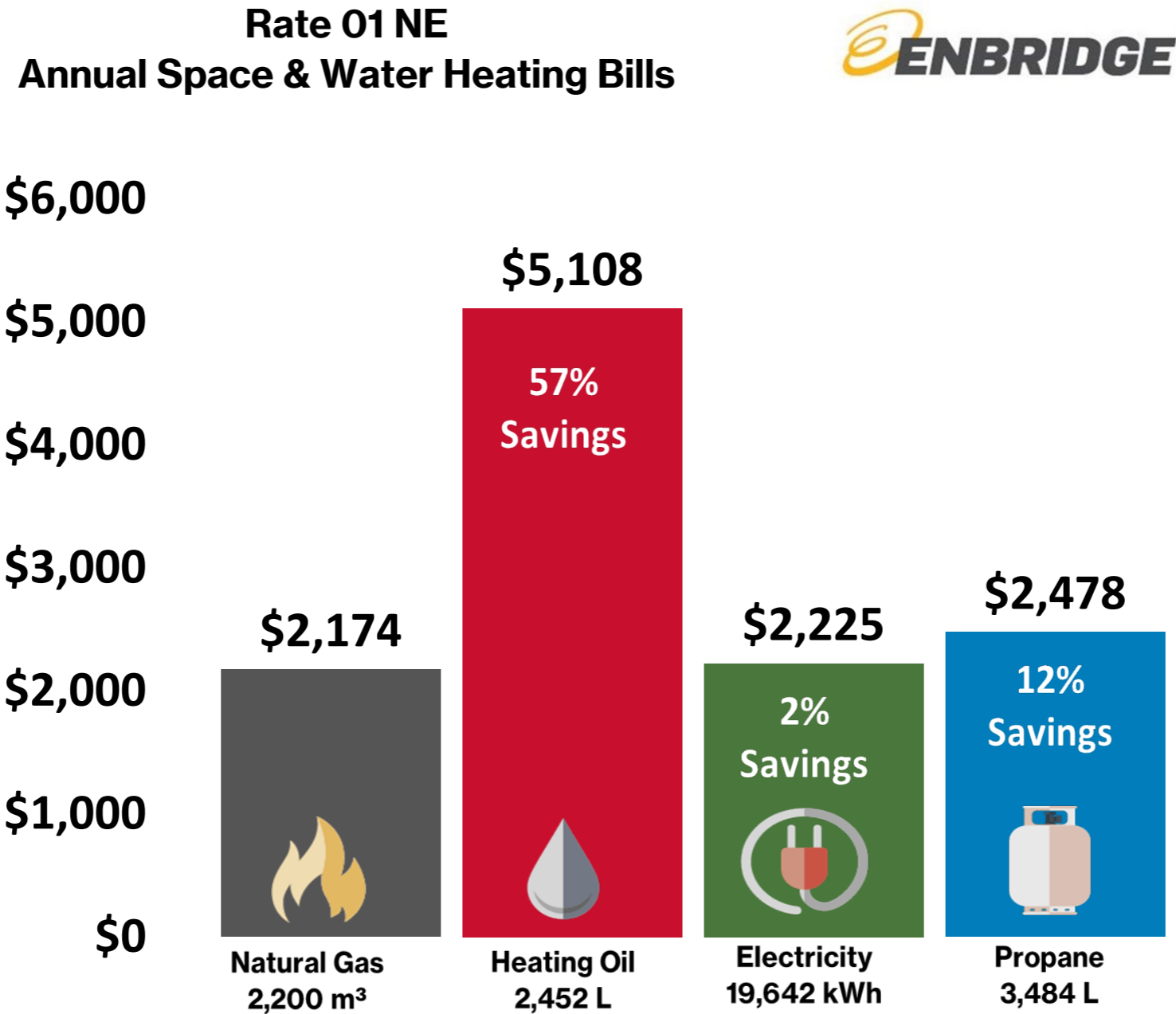

Notes: Natural gas price is based on Rate 01 NE rates in effect as of Jan. 1, 2023, and includes the \$0.23 per m³ expansion surcharge. Oil and propane prices are based on the latest available retail prices at the time of comparison. Electricity rates based on Hydro One Distribution rates (Mid-density R1) as of Jan. 1, 2023, and Regulated Price Plan (RPP) customers that are on Time-Of-Use (TOU) pricing. It includes the Ontario Electricity Rebate (OER). Propane price is based on the latest available retail prices at the time of comparison in our Rate M1 Union South area discounted by 10% as a conservative estimate. Since individual fuel prices may vary, savings assumptions may or may not be accurate in your situation. Please go to the calculator at savewithgas.com for a more accurate savings estimate. Costs have been calculated for the equivalent energy consumed and include all service, delivery and energy charges. Carbon price is included for all energy types as reported. HST is not included.

Table 1: Annual Energy Price Comparison for a Typical Residential Customer living in Union North Rate Zone (Space & Water Heating) Including SES

				
	Natural Gas	Heating Oil	Electricity	Propane
	\$0.988/m ³	\$2.083/L	\$0.113/kWh	\$0.711/L
Annual Consumption	2,200	2,452	19,642	3,484
Annual Contribution to Energy Bill	\$2,174	\$5,108	\$2,225	\$2,478
Energy Cost per Unit	\$0.988	\$2.083	\$0.113	\$0.711
Annual Natural Gas Savings (\$)		\$2,934	\$50	\$304
Annual Natural Gas Savings (%)		57%	2%	12%

Notes

(1) Annual Consumption

For Union rate zone, the natural gas consumption assumption for a typical residential customer is 2,200m³. All comparisons are based on an energy-equivalent annual consumption level of 2,200 m³/yr.

The energy-equivalent annual consumption for other energy sources (Electricity, Oil and Propane) are calculated as:

Natural gas consumption (2,200 m³) * Conversion from m³ to GJ * Conversions from GJ to kWh (for electricity) and to L (for oil and propane)

(2) Energy Cost per Unit

The energy cost per unit for each energy source is based on the latest actual data available

- a) Natural Gas cost per unit for a typical residential customer is from the January 2023 QRAM filing for Union Northeast. Please refer to 'Natural Gas Price (\$ per m³)' tab for a detailed calculation.
- b) Oil cost per unit is from Statistics Canada using the latest available monthly retail price at the time of comparison. Please refer to 'Heating Oil Price (\$ per L)' tab for a detailed calculation.
- c) Electricity cost per unit is from Hydro One Networks Inc. (EB-2021-0110), Tariff of Rates and Charges, Effective and Implementation Date January 1, 2023. Please refer to 'Electricity Price (\$ per kWh)' tab for a detailed calculation.
- d) Propane cost per unit is calculated using a monthly average of the latest residential retail prices available at the time of comparison and factors in the actual carbon tax and is discounted by 10% for Union North for a conservative estimate. Please refer to 'Propane Price (\$ per L)' tab for a detailed calculation.

Figure 2: Annual Energy Costs & Savings Versus Natural Gas, Including SES (First Nations Commu

**Rate 01 NE (First Nations)
Annual Space & Water Heating Bills**

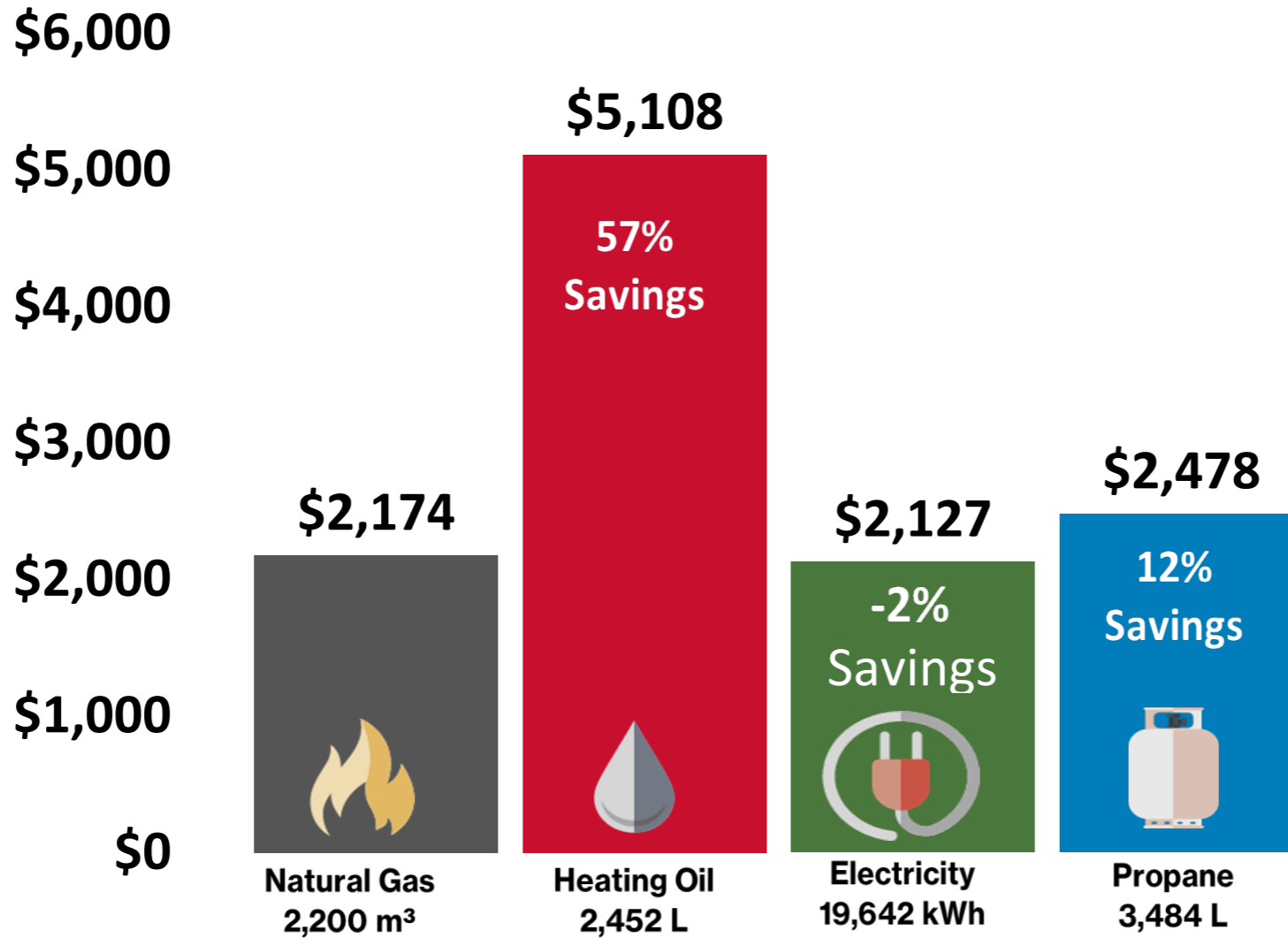

Notes: Natural gas price is based on Rate 01 NE rates in effect as of Jan. 1, 2023, and includes the \$0.23 per m³ expansion surcharge. Oil and propane prices are based on the latest available retail prices at the time of comparison. Electricity rates based on Hydro One Distribution rates (Mid-density R1) as of Jan. 1, 2023, and Regulated Price Plan (RPP) customers that are on Time-Of-Use (TOU) pricing. It includes the Ontario Electricity Rebate (OER) and excludes distribution charges per First Nations Delivery Credit. Propane price is based on the latest available retail prices at the time of comparison in our Rate M1 Union South area discounted by 10% as a conservative estimate. Since individual fuel prices may vary, savings assumptions may or may not be accurate in your situation. Please go to the calculator at savewithgas.com for a more accurate savings estimate. Costs have been calculated for the equivalent energy consumed and include all service, delivery and energy charges. Carbon price is included for all energy types as reported. HST is not included.

Table 2: Annual Energy Price Comparison for a Typical Residential Customer living in Union North Rate Zone (Space & Water Heating) Including SES (First Nations Communities)

				
	Natural Gas	Heating Oil	Electricity	Propane
	\$0.988/m ³	\$2.083/L	\$0.108/kWh	\$0.711/L
Annual Consumption	2,200	2,452	19,642	3,484
Annual Contribution to Energy Bill	\$2,174	\$5,108	\$2,127	\$2,478
Energy Cost per Unit	\$0.988	\$2.083	\$0.108	\$0.711
Annual Natural Gas Savings (\$)		\$2,934	-\$47	\$304
Annual Natural Gas Savings (%)		57%	-2%	12%

Notes

(1) Annual Consumption

For Union rate zone, the natural gas consumption assumption for a typical residential customer is 2,200m³. All comparisons are based on an energy-equivalent annual consumption level of 2,200 m³/yr.

The energy-equivalent annual consumption for other energy sources (Electricity, Oil and Propane) are calculated as:

Natural gas consumption (2,200 m³) * Conversion from m³ to GJ * Conversions from GJ to kWh (for electricity) and to L (for oil and propane)

(2) Energy Cost per Unit

The energy cost per unit for each energy source is based on the latest actual data available

- a) Natural Gas cost per unit for a typical residential customer is from the January 2023 QRAM filing for Union Northeast. Please refer to 'Natural Gas Price (\$ per m³)' tab for a detailed calculation.
- b) Oil cost per unit is from Statistics Canada using the latest available monthly retail price at the time of comparison. Please refer to 'Heating Oil Price (\$ per L)' tab for a detailed calculation.
- c) Electricity cost per unit is from Hydro One Networks Inc. (EB-2021-0110), Tariff of Rates and Charges, Effective and Implementation Date January 1, 2023. Please refer to 'Electricity Price (\$ per kWh)' tab for a detailed calculation.
- d) Propane cost per unit is calculated using a monthly average of the latest residential retail prices available at the time of comparison and factors in the actual carbon tax and is discounted by 10% for Union North for a conservative estimate. Please refer to 'Propane Price (\$ per L)' tab for a detailed calculation.

Conversions

<u>Table 1</u> <u>Conversion from m3 to GJ</u>	
Union Rate Zone - North (1)	
Conversion factor	0.0388

Note

(1) Source: <https://www.enbridgegas.com/storage-transportation/doing-business-with-us/unit-measure-conversion-information> (April 1/22 - North)

<u>Table 2</u> <u>Energy Price Conversion</u>			
Substance	Starting Unit	Conversion	Conversion Unit
Electricity	GJ	277.7777778	kWh
Heating Oil	GJ	27.23311547	L
Propane	GJ	39.16960439	L

<u>Table 3</u> <u>Efficiency Assumptions</u> <u>Union Rate Zone</u>			
<u>Natural Gas</u>	<u>Electricity</u>	<u>Heating Oil</u>	<u>Propane</u>
82%	99%	78%	79%

<u>Table 1</u>		
Typical Residential Customer Total Bill Impacts (1)		
Union North East		
Rates Effective: <u>Jan. 1, 2023</u>		
Volume	m3	2,200
Customer Charge	\$	287.76
Distribution Charge	\$	245.10
Storage	\$	135.15
Transportation	\$	47.45
Sales Commodity	\$	577.16
Federal Carbon Charge	\$	215.38
Cost Adjustment	\$	
Gas Supply	\$	161.31
Transportation	\$	(0.78)
Delivery	\$	0.00
		160.53
Total Sales with Cost Adjustments	\$	1,668.53
Average Rate	\$	0.76
System Expansion Surcharge (SES)	\$	0.23
Average Rate including SES	\$	0.99

Notes:

(1) Source: EB-2022-0286, Exhibit A, Tab 3, Schedule 1, Page 2

Table 1
Home Heating Oil (HHO) (1)

Month	Federal/Provincial Carbon Tax Charge HHO (2)	HHO (v735163) (3)	HHO (excl. GST/HST)	HHO (excl. tax and C&T)
Jan-22	7.83	162.8	144.07	136.24
Feb-22	7.83	179.5	158.85	151.02
Mar-22	7.83	213.4	188.85	181.02
Apr-22	9.79	210.7	186.46	176.67
May-22	9.79	258.7	228.94	219.15
Jun-22	9.79	231.9	205.22	195.43
Jul-22	9.79	219.3	194.07	184.28
Aug-22	9.79	205.3	181.68	171.89
Sep-22	9.79	207.1	183.27	173.48
Oct-22	9.79	235.4	208.32	198.53
Nov-22				
Dec-22				
Total \$/L	2.083			

Notes

- (1) all prices in cents/litre
- (2) Source: <https://natural-resources.canada.ca/our-natural-resources/domestic-and-international-markets/transportation-fuel-prices/fuel-consumption-taxes-canada/18885>
Federal and Provincial Carbon Levies (Alberta, Saskatchewan, Manitoba,
- (3) Source: the Conference Board of Canada (CANSIM) - v735163

Ontario Energy Rebate (OER): 11.7% (1)

Table 1 Regulated Price Plan -TOU Time of Use			
	Cents/kWh (2)	% of Load (3)	
On Peak	15.10	18%	
Mid Peak	10.20	18%	
Off Peak	7.40	64%	
Total Load - cent/KWh	9.29		
Total Load - \$/kWh	0.0929		

Notes:

- (1) Source: OEB Newsroom - Friday Oct. 21, 2022
- (2) TOU rates effective from November 1, 2022 to April 30, 2023
- (3) Source: OEB Regulated Price Plan Price Report - November 1, 2021 to October 31, 2022

Table 2 Hydro One Electricity Rates Medium Density - R1 (1)	
Rates Effective <u>1-Jan-2023</u>	
Service Charge (2)	60.72 \$/month
Distribution Rate	0.0056 \$/kWh
Transmission	0.0188 \$/kWh
Wholesale Market Service Rate + CBR	0.0034 \$/kWh
Rural rate protection charge	0.0005 \$/kWh
Adjustment Factor Charge	1.076
Standard Supply Service Charge	0.25 \$/month
Fixed Charge Rate Riders	
SME	0.42 \$/month
<hr/>	
Total \$/kWh	0.1283 \$/kWh
Total \$/kWh with OER	0.1133 \$/kWh
Total \$/kWh with OER, no distribution charge	0.1083 \$/kWh

Notes:

- (1) Source: EB-2021-0110 Hydro One Networks Inc. Tariff of Rates and Charges, Effective and Implementation Date January 1, 2023
Medium Density - R1
- (2) Excluded for cost comparison purposes

Ending Value Oct. 28, 2022 (cents/L) 72.80 (1)

Table 1 Propane Prices for Residential South Rate M1 Customer						
Date	\$/L	Cents/L	Daily Price Change (2)	Carbon Tax (3)	Total	
28-Oct-2022	0.7280	72.80	0.40	0.0774	0.8054	
29-Oct-2022	0.7280	72.80	0.00	0.0774	0.8054	
30-Oct-2022	0.7280	72.80	0.00	0.0774	0.8054	
31-Oct-2022	0.7280	72.80	0.00	0.0774	0.8054	
01-Nov-2022	0.7280	72.80	0.00	0.0774	0.8054	
02-Nov-2022	0.7280	72.80	0.00	0.0774	0.8054	
03-Nov-2022	0.7280	72.80	0.00	0.0774	0.8054	
04-Nov-2022	0.7210	72.10	(0.70)	0.0774	0.7984	
05-Nov-2022	0.7250	72.50	0.40	0.0774	0.8024	
06-Nov-2022	0.7250	72.50	0.00	0.0774	0.8024	
07-Nov-2022	0.7250	72.50	0.00	0.0774	0.8024	
08-Nov-2022	0.7340	73.40	0.90	0.0774	0.8114	
09-Nov-2022	0.7220	72.20	(1.20)	0.0774	0.7994	
10-Nov-2022	0.7190	71.90	(0.30)	0.0774	0.7964	
11-Nov-2022	0.7190	71.90	0.00	0.0774	0.7964	
12-Nov-2022	0.7190	71.90	0.00	0.0774	0.7964	
13-Nov-2022	0.7190	71.90	0.00	0.0774	0.7964	
14-Nov-2022	0.7190	71.90	0.00	0.0774	0.7964	
15-Nov-2022	0.7190	71.90	0.00	0.0774	0.7964	
16-Nov-2022	0.7190	71.90	0.00	0.0774	0.7964	
17-Nov-2022	0.7140	71.40	(0.50)	0.0774	0.7914	
18-Nov-2022	0.7140	71.40	0.00	0.0774	0.7914	
19-Nov-2022	0.7090	70.90	(0.50)	0.0774	0.7864	
20-Nov-2022	0.7090	70.90	0.00	0.0774	0.7864	
21-Nov-2022	0.7090	70.90	0.00	0.0774	0.7864	
22-Nov-2022	0.7090	70.90	0.00	0.0774	0.7864	
23-Nov-2022	0.7090	70.90	0.00	0.0774	0.7864	
24-Nov-2022	0.6940	69.40	(1.50)	0.0774	0.7714	
25-Nov-2022	0.6940	69.40	0.00	0.0774	0.7714	
26-Nov-2022	0.6940	69.40	0.00	0.0774	0.7714	
27-Nov-2022	0.6940	69.40	0.00	0.0774	0.7714	
28-Nov-2022	0.6940	69.40	0.00	0.0774	0.7714	
29-Nov-2022	0.6880	68.80	(0.60)	0.0774	0.7654	
30-Nov-2022	0.6880	68.80	0.00	0.0774	0.7654	
November Monthly Average		71.29				
Current Price:		71.29				
Carbon Tax:		7.74				
Total Cents/L		79.03				
\$/L		0.79033				
Rate M1 South Residential		0.7903 \$/L				
Rate 01 North East/North West Residential (4)		0.7113 \$/L				

Notes:

- (1) Last recorded daily price change from the previous month
- (2) Source: <https://edproenergy.com/residential/> ; Zone 1, 2,500-4,499 Litres
- (3) Source: <https://www.canada.ca/en/revenue-agency/services/forms-publications/publications/fcrates/fuel-charge-rates.html>
- (4) North Propane price is based on the latest available retail prices at the time of comparison in our Rate M1 Union South area discounted by 10% as a conservative estimate. Since individual fuel prices may vary, savings assumptions may or may not be accurate in your situation. Please go to the calculator at savewithgas.com for a more accurate savings estimate.



Rate 01 NE Annual Space & Water Heating Bills

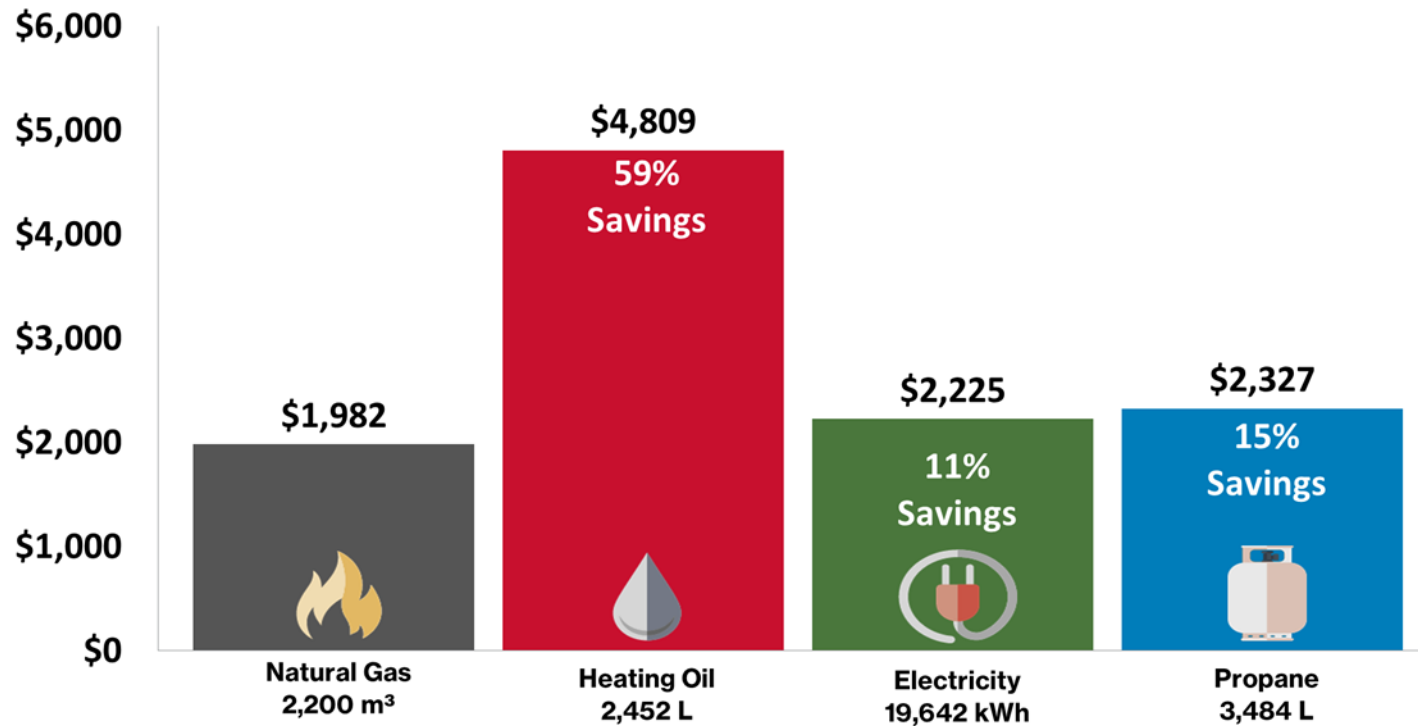

Notes: Natural gas price is based on Rate 01 NE rates in effect as of Apr. 1, 2023, and includes the \$0.23 per m³ expansion surcharge. Oil and propane prices are based on the latest available retail prices. Electricity rates based on Hydro One Distribution rates (Mid-density R1) as of Jan. 1, 2023, and Regulated Price Plan (RPP) customers that are on Time-Of-Use (TOU) pricing. It includes the Ontario Electricity Rebate (OER). Propane price is based on the latest available retail prices in our Rate M1 Union South area discounted by 10% as a conservative estimate. Since individual fuel prices may vary, savings assumptions may or may not be accurate in your situation. Please go to the calculator at savewithgas.com for a more accurate savings estimate. Costs have been calculated for the equivalent energy consumed and include all service, delivery and energy charges. Carbon price is included for all energy types as reported. HST is not included.



Rate 01 NE (First Nations) Annual Space & Water Heating Bills

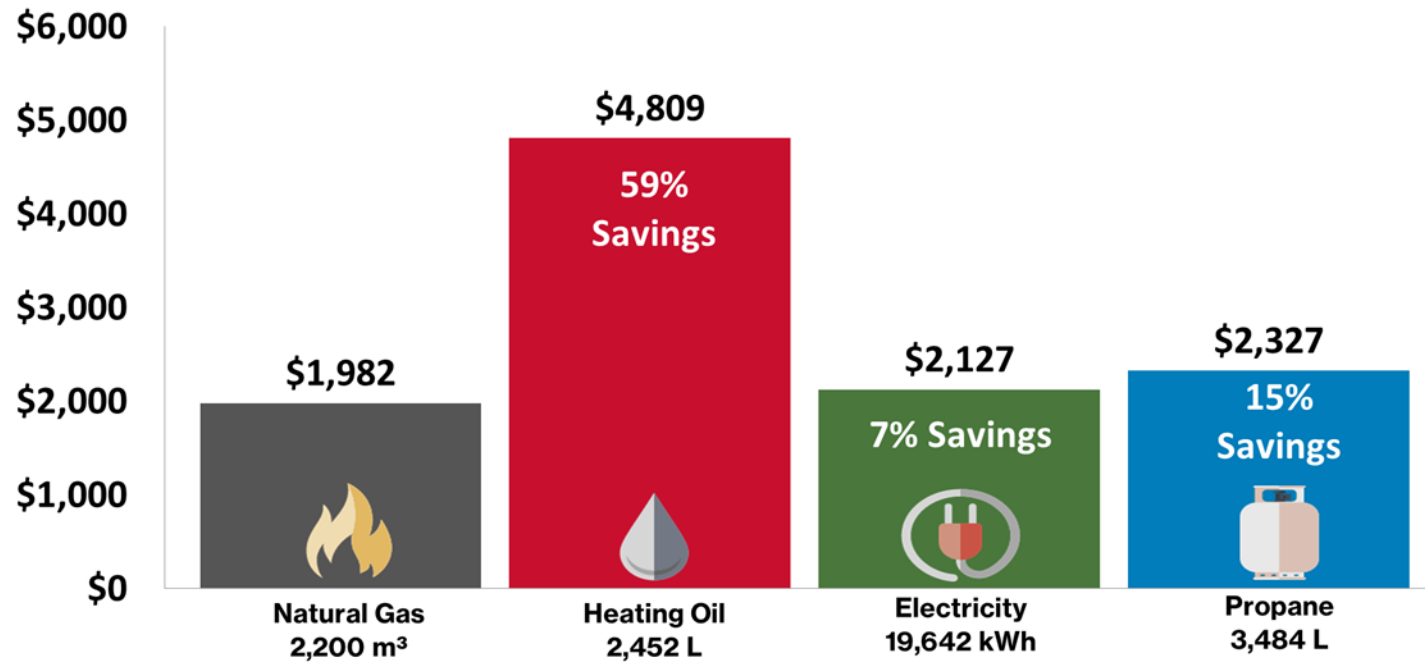

Notes: Natural gas price is based on Rate 01 NE rates in effect as of Apr. 1, 2023, and includes the \$0.23 per m³ expansion surcharge. Oil and propane prices are based on the latest available retail prices. Electricity rates based on Hydro One Distribution rates (Mid-density R1) as of Jan. 1, 2023, and Regulated Price Plan (RPP) customers that are on Time-Of-Use (TOU) pricing. It includes the Ontario Electricity Rebate (OER) and excludes distribution charges per First Nations Delivery Credit. Propane price is based on the latest available retail prices in our Rate M1 Union South area discounted by 10% as a conservative estimate. Since individual fuel prices may vary, savings assumptions may or may not be accurate in your situation. Please go to the calculator at savewithgas.com for a more accurate savings estimate. Costs have been calculated for the equivalent energy consumed and include all service, delivery and energy charges. Carbon price is included for all energy types as reported. HST is not included.

ENBRIDGE GAS INC.

Answer to Interrogatory from
Environmental Defence (“ED”)

INTERROGATORY

Reference:

Exhibit B, Tab 1, Schedule 1, Page 2

Question(s):

- (a) Please provide all communications from Enbridge to the Mohawks of the Bay of Quinte First Nation regarding the project, including all communications describing the benefits (e.g. letters, presentations, etc.).
- (b) Please provide all communications between Enbridge and the Township regarding the project, including all communications describing the benefits (e.g. letters, presentations, etc.).

Response

- (a) Details of Enbridge Gas’s communications with the Mohawks of the Bay of Quinte First Nation (“MBQ”) are set out at Exhibit H, including Project-specific information provided. Additionally, Attachment 1 to this response contains the generic natural gas marketing brochure distributed to potential customers across the Project area, including to members of MBQ. Please also see the response to Exhibit I.STAFF.10, for a summary update of additional consultation activities since December 15, 2022.
- (b) An update to Appendix F of the Environmental Report,¹ including a log containing details of Enbridge Gas’s communications with affected municipalities is set out in Attachment 2 to this response. Certain supporting materials identified within Attachment 2 were included within the Company’s pre-filed evidence:
- Mohawks of the Bay of Quinte & Township of Tyendinaga Natural Gas Questionnaire,²

¹ Exhibit F, Tab 1, Schedule 1, Attachment 1, Appendix F

² Exhibit B, Tab 1, Schedule 1, Attachment 3

- Notice of Study Commencement and Virtual Information Session,³ and
- Letter of Support.⁴

The virtual presentation made to Council dated May 2, 2022, as identified within Attachment 2, is set out at Attachment 3 to this response.

³ Exhibit F, Tab 1, Schedule 1, Attachment 1

⁴ Exhibit B, Tab 1, Schedule 1, Attachment 2

Choose to pay less for energy

Save up to 65% each year
by switching to natural gas

What's inside:



See how
much you
can save



5-step
guide to get
connected



Ready to cut energy bills in half?

Good news— natural gas is a convenient solution to help you save. This package will guide you through everything you need to know about connecting your home or business and all the benefits of affordable, reliable natural gas.

Save up to 65 percent* each year

Compared to electricity, propane or oil, switching to natural gas could save you on home and water heating costs year round. It's more convenient: you'll never run out of fuel or wait for trucks to arrive.

Lower carbon emissions

Natural gas is cleaner than other fuels and can help reduce your home's carbon footprint.

It's easy to get started

Follow our simple five-step guide on page six to see how the connection process works.

See how much you can save

Use our online calculator to see how much you can save by switching to natural gas. Enter your home's size, age and a few more details to get a personalized estimate of annual savings.

Calculate your savings by visiting enbridgegas.com/savewithgas and finding your community page to use the calculator.

Ahmed Al-Amry

Ahmed Al-Amry
Supervisor, Community Expansion
Enbridge Gas



Get in touch any time

For construction updates or questions about the steps to connect to natural gas, personalized cost savings and more, contact one of our Community Expansion Advisors.

Community Expansion Contacts:

Phone: 1-833-356-2689

Email: ceapplications@enbridge.com

* Natural gas prices are based on Rate M1 rates in effect as of **April 1, 2023** and include the \$0.23 per m³ expansion surcharge. Oil price is based on the latest available retail price. Electricity rates based on Hydro One Distribution rates (Mid-density R1) as of **Jan. 1, 2023** and Regulated Price Plan (RPP) customers that are on Time-Of-Use (TOU) pricing. They include the new Ontario Electricity Rebate (OER). The propane price comparison is based on the lowest price obtained in an area survey conducted quarterly. Since individual fuel prices vary, savings assumptions may or may not be as accurate in your situation. Please use the savings calculator found on this page for a more accurate savings estimate. Costs have been calculated for the equivalent energy consumed and include all service, delivery and energy charges. Carbon price is included for all energy types as reported. HST is not included.

Cost and benefits

How much can you save each year?

Lower costs, lower emissions, more convenience and peace of mind.

Residential annual heating bills

Annual cost comparison: space and water heating*

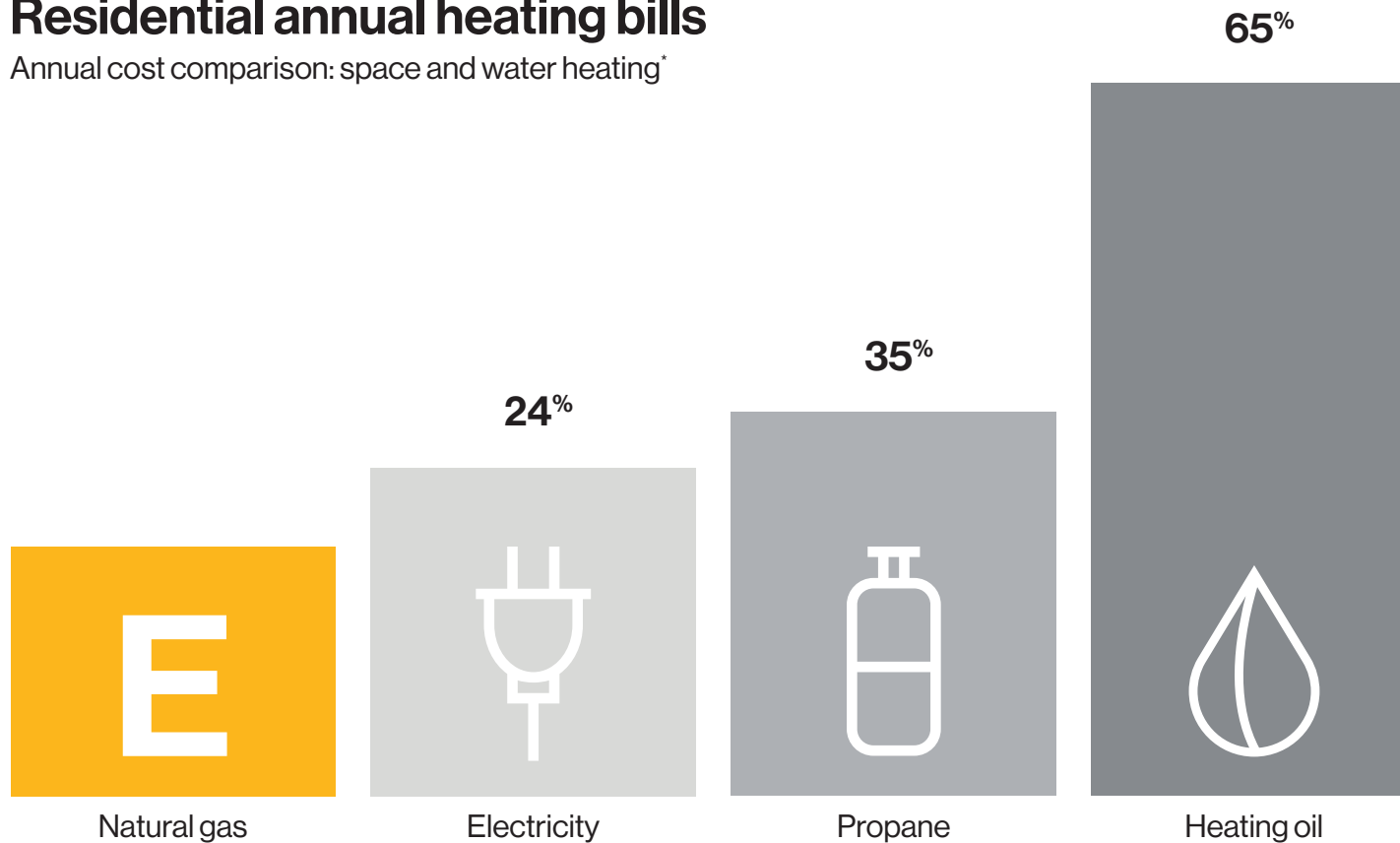

* Natural gas prices are based on Rate M1 rates in effect as of **April 1, 2023** and include the \$0.23 per m³ expansion surcharge. Oil price is based on the latest available retail price. Electricity rates based on Hydro One Distribution rates (Mid-density R1) as of **Jan. 1, 2023** and Regulated Price Plan (RPP) customers that are on Time-Of-Use (TOU) pricing. They include the new Ontario Electricity Rebate (OER). The propane price comparison is based on the lowest price obtained in an area survey conducted quarterly. Since individual fuel prices vary, savings assumptions may or may not be as accurate in your situation. Please use the savings calculator found on this page for a more accurate savings estimate. Costs have been calculated for the equivalent energy consumed and include all service, delivery and energy charges. Carbon price is included for all energy types as reported. HST is not included.

Bring home all the benefits



More affordable

Compared to other fuels and electricity, natural gas is the most cost-effective way to heat your home and water.



Comfort and convenience

Never worry about running out of fuel or waiting for deliveries again.



Versatile and efficient

From fireplaces to clothes dryers, natural gas can make your home more comfortable and enjoyable.



Lower carbon emissions

Natural gas can help reduce your home's carbon footprint.

Billing and charges

Where does your money go?

Here's a helpful explanation of a few key items on your natural gas bill

Expansion Surcharge

The fairest way to cover the infrastructure costs of expanding natural gas service.

Cost Adjustment

Natural gas rates vary by season—you pay what we pay.

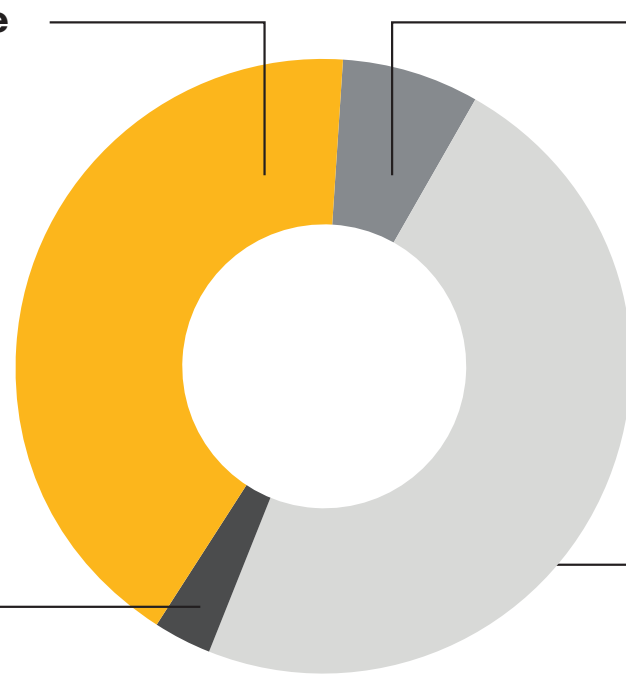

Customer Charge

This is a fixed \$23.98* amount that pays for 24/7 emergency response and other services.

* Subject to change. Please note that all charges, except the fixed customer charge, vary based on how much natural gas you use.

Supply, Delivery and Transportation Charges

These cover the costs to buy and deliver natural gas to your home.

Frequently asked questions

Q: Why do I have to pay an additional charge towards the construction costs of the project?

A: For us to extend natural gas to rural areas where the cost of building the infrastructure is more than the revenue it generates, the Ontario Energy Board approved an additional expansion surcharge. This is a variable rate charge, based on your usage, of \$0.23/cubic metre of natural gas used. Since homes use more natural gas in colder months, the surcharge will be higher in winter. It will appear as a separate line item on your monthly bill for up to 40 years.

Go to enbridgegas.com/savewithgas to get an estimate of your potential fuel savings.

Q: Why is the surcharge in effect for different lengths of time by community?

A: The length of time the surcharge remains in effect varies by community because the overall cost to serve each community is different, based on factors such as the distance of the community from an existing natural gas pipeline and more.

“We’ve saved all kinds of money by converting to natural gas, especially over the cost of hydro these days. It just made sense.”

**– Phil Dewsnap,
Homeowner,
Fenelon Falls**



“I live in a rural region. That means I have my own septic, my own water, and if things don’t work, I’m in real trouble. Natural gas has helped me be more independent and I saved a really good buck.”

– John Powell, Homeowner, Scugog Island

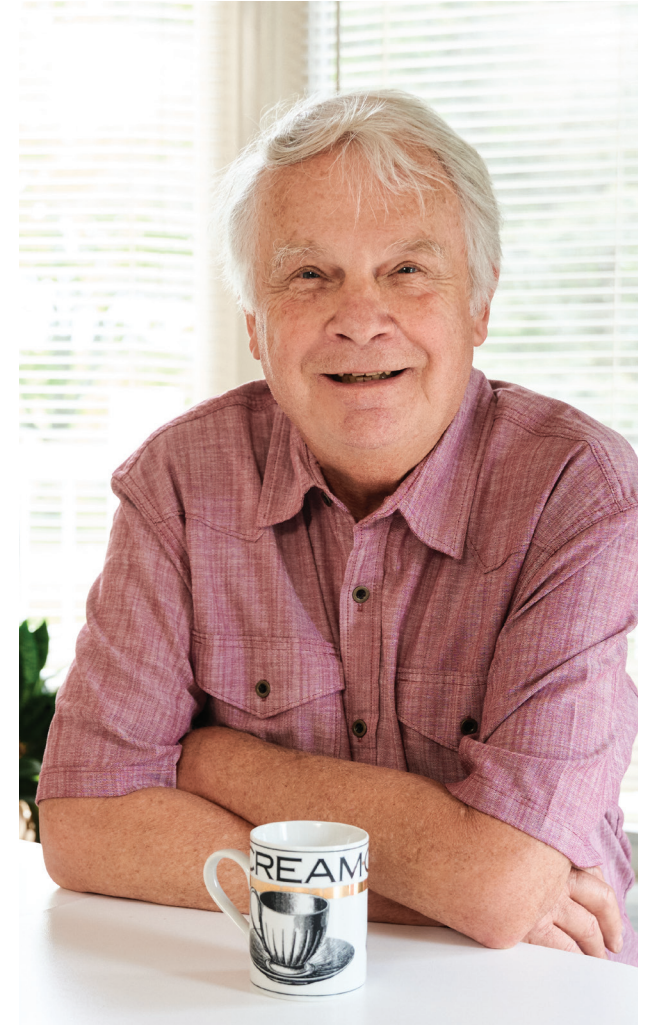

“The advice I would give others is to convert to natural gas. We’ve seen a lot of energy savings, the conversion was simple and you get some extra money in your pocket, so it’s worth doing.”

– Phil Dewsnap, Homeowner, Fenelon Falls

How to get connected

5 simple steps to switch

It's always best to complete your application for natural gas service as early as possible. This helps us to ensure you are included in our planning process.



1. Inquire with us

Visit enbridgegas.com/savewithgas to review project details, calculate your estimated savings and engage with our project team to answer any of your questions.



2. Get an estimate from your local heating contractor

Once you have made your decision to convert, your contractor will submit the natural gas service application on your behalf. You will receive an email summary of the gas application as submitted by your contractor.

A member of our team will contact you to coordinate locating and marking all existing underground utilities.



3. Acknowledge your account details

You will receive a confirmation email with a verification link prompting you to validate the following: your service address, homeowner and billing information.

You will be provided details on the expansion surcharge, which will fluctuate monthly based on your natural gas use. Even with this surcharge, you can still save significantly every year by switching to natural gas.



4. After we install the natural gas service

Contact your contractor to arrange for the gas meter installation and conversion of your natural gas equipment.



5. The final step

Your new natural gas equipment will be turned on and inspected as required by the Technical Standards and Safety Act.

Natural gas service installation policy

Enbridge Gas will provide and install at no cost, one service line per civic address to new customers which will include up to 30 metres of laid pipe and anything beyond that would be \$45 per metre (plus applicable taxes). Call your local heating, ventilation and air conditioning (HVAC) provider for an assessment and to submit an application for gas service.

IMPORTANT!

Do not disconnect your existing fuel source or remove any equipment until your new natural gas service and gas meter have been installed.

Take the first step to savings

Let us know you're interested in connecting to natural gas



Please send the following information to ceapplications@enbridge.com and a Community Expansion Advisor will contact you soon.

Name (please print)

Address

Phone number

Email address

Existing Primary Heat Source

Existing Secondary Heat Source

Signature

Date

Get in touch any time



Prefer postal mail?

Mail your completed expression of interest to us at:

Enbridge Gas
Community Expansion
PO Box 618
Bobcaygeon, ON K0M 1A0



Questions?

We're here for you.

Contact a Community Expansion Advisor:

1-833-356-2689
ceapplications@enbridge.com

Completing this Expression of Interest Card is not an application for natural gas, or a binding contract by either you or Enbridge Gas for natural gas service.



ENBRIDGE GAS INC.

Mohawks of the Bay of Quinte and Shannonville Community Expansion Project

Stakeholder Engagement Log

Agency Correspondence

Line Item	Date of Consultation	Name of Agency and/or Contact	Description of Consultation Activity	Date of Response	Response and Issue Resolution (if applicable)
FEDERAL AGENCIES AND ELECTED OFFICIALS					
1.1	May 3, 2022	Member of Parliament Hastings – Lennox and Addington <i>Contact: Shelby Kramp-Neuman</i>	Enbridge representative provided the Notice of Commencement via email.	N/A	N/A
2.1	February 22, 2022	Crown-Indigenous Relations and Northern Affairs Canada (CIRNAC) <i>Contacts: Environmental Assessment Office and the Honourable (Hon.) Mark Miller (Minister of Crown-Indigenous Relations)</i>	Dillon representative sent an email requesting appropriate contact person within CIRNAC to discuss <i>Impact Assessment Act</i> requirements for a project on Indian Reserve lands in Ontario.	N/A	N/A
2.2	February 28, 2022	CIRNAC <i>Contacts: Environmental Assessment Office, Hon. Marc Miller, Public Enquiries Contact Centre</i>	Dillon representative followed up on February 22 email requesting the appropriate CIRNAC contact to discuss <i>Impact Assessment Act</i> requirements for a project on Indian Reserve lands in Ontario.	February 28, 2022	A representative from the Public Enquiries Contact Centre at CIRNAC responded stating that the Dillon representative's message was redirected to the appropriate department.
2.3	March 8, 2022	CIRNAC <i>Contact: Public Enquiries Contact Centre</i>	Dillon representative followed up with representative from the Public Enquiries Contact Centre at CIRNAC stating they had not yet heard back from anyone and asked if there was a phone number or contact person that they could reach out to directly.	March 8, 2022	A representative from the Public Enquiries Contact Centre at CIRNAC responded with the email address to contact the environmental assessment team.
2.4	March 8, 2022	CIRNAC <i>Contact: Environmental Assessment Office</i>	Dillon representative reached out the Environmental Assessment Office again requesting the appropriate contact person within CIRNAC to discuss <i>Impact Assessment Act</i> requirements for a project on Indian Reserve lands in Ontario.	N/A	N/A
3.1	March 21, 2022	Impact Assessment Agency of Canada (IAAC) <i>Contacts: Ontario Regional Office and Anjala Puvananathan</i>	Dillon representative sent an email stating that they are looking to discuss <i>Impact Assessment Act</i> requirements for a project on Indian Reserve lands in Ontario. Dillon representative noted that the project is not a designated project and does not otherwise trigger the <i>Impact Assessment Act</i> . Dillon representative noted that they had reached out to CIRNAC, assuming they would be the responsible authority, but had not heard back despite multiple attempts to reach someone.	N/A	N/A
3.2	March 29, 2022	IAAC <i>Contact: Patricia McKeage</i>	Dillon representative received a phone call from IAAC representative in response to their March 21 email requesting a contact person to discuss <i>Impact Assessment Act</i> requirements for the Project. The IAAC representative noted that the IAAC has no authority over the Project since it is not a "designated project" under the <i>Physical Activities Regulations</i> . IAAC representative stated that Dillon should contact ISC rather than CIRNAC and provided the name of a contact at ISC along with the phone number of the ISC Toronto Regional Office.	N/A	N/A

Line Item	Date of Consultation	Name of Agency and/or Contact	Description of Consultation Activity	Date of Response	Response and Issue Resolution (if applicable)
4.1	March 30, 2022	Indigenous Services Canada (ISC) <i>Contact: Isabelle Levesque</i>	Dillon representative called and left a voicemail for the ISC representative to discuss the Project.	N/A	N/A
4.2	April 6, 2022	ISC <i>Contact: Isabelle Levesque</i>	Dillon representative emailed ISC representative to follow up on the voicemail they had left on March 30. Dillon representative noted that they are looking to identify the responsible federal authority for a project that triggers Section 82 of the <i>Impact Assessment Act</i> , as it is located on federal lands (Tyendinaga Mohawk Territory). Dillon representative noted that the Project is proceeding through the Ontario Energy Board regulatory process and they would like to confirm federal approvals in order to keep the Project schedule on track.	April 6, 2022	ISC representative responded stating they were having issues with their work phone and apologized for missing Dillon representative's call on March 30. ISC representative stated they could meet on April 7 or 8 via video conference and asked Dillon representative to provide their availability so they can send out a meeting invite.
4.3	April 6, 2022	ISC <i>Contacts: Isabelle Levesque and Christina Rakobowchuk</i>	Dillon representative responded to ISC representative with times that they would be available for a video conference on April 7.	April 6, 2022	ISC representative sent out a Microsoft Teams meeting invite for April 7 at 2 pm.
4.4	April 7, 2022	ISC <i>Contact: Isabelle Levesque and Christina Rakobowchuk</i>	Dillon representatives met with ISC representatives via video conference. An overview of the Project was provided and ISC representatives stated they would direct Dillon representatives to the appropriate ISC Environmental Officer for further information.	N/A	N/A
4.5	April 8, 2022	ISC <i>Contact: Isabelle Levesque</i>	ISC representative reached out to Dillon representatives noting it was nice meeting on April 7 and stated that they contacted their Regional Office to get a contact name for an Environmental Officer. ISC representative stated that they would reconnect once they hear back from the Regional Office.	April 8, 2022	Dillon representative thanked ISC representative for the update.
4.6	April 8, 2022	ISC <i>Contacts: Isabelle Levesque, Christina Rakobowchuk, Cynthia Brown, and Ricky Wai Kei Chiu</i>	ISC representative provided contact information for two ISC Environmental Officers for the Ontario Region.	April 8, 2022	Dillon representative thanked ISC representative for the Environment Officers' contact information and inquired with the ISC Environmental Officers (also on the email) if they would be available next week for a call to go over the Project.
4.7	April 11, 2022	ISC <i>Contact: Ricky Wai Kei Chiu</i>	ISC representative thanked Dillon representative for reaching out and noted that ISC may be a Federal Authority to complete the Section 82 determination under the <i>Impact Assessment Act</i> , if they are issuing a permit or funding for a project on Reserves. ISC representative stated that they are working to gather the availability of their counterparts at the Land Unit and Infrastructure Group and will provide potential meeting times soon.	April 11, 2022	Dillon representative thanked ISC representative.
4.8	April 13, 2022	ISC <i>Contacts: Ricky Wai Kei Chiu, Julieta Werner, Kristen Kayseas, Cynthia Brown</i>	ISC representative sent Dillon representatives a Microsoft Teams meeting invite for April 19 at 1:30 pm and asked if the Dillon representatives would be available for a meeting at that time.	April 13, 2022	Dillon representative confirmed the suggested time would work for them and accepted the meeting invite.

Line Item	Date of Consultation	Name of Agency and/or Contact	Description of Consultation Activity	Date of Response	Response and Issue Resolution (if applicable)
4.9	April 19, 2022	ISC <i>Contacts: Ricky Wai Kei Chiu, Cynthia Brown, Kristen Kayseas, Julieta Werner, Selina Aivaliotis, and Roger Dockstader</i>	Dillon representatives met with ISC representatives via video conference. Dillon representatives provided an overview of the Project and a discussion was had regarding the applicability of the <i>Impact Assessment Act</i> and what steps Enbridge Gas and Dillon would need to take to meet federal environmental assessment requirements. ISC representative from Land Unit advised that in preparation for the meeting, they had found an existing <i>Indian Act</i> permit issued to Union Gas for a natural gas pipeline on the Tyendinaga Mohawk Territory and suggested Enbridge Gas do some internal research to determine whether the existing permit could be amended. ISC representative noted that as a first step in the federal review process they would need Enbridge Gas to submit an Environmental Review Process Project Description Form and that ISC could provide the form after the meeting for reference.	April 19, 2022	ISC representative from Land Unit followed up after the meeting to provide, for reference, the existing Development Permit that had been granted to Union Gas under the <i>Indian Act</i> in 2016.
4.10	April 19, 2022	ISC <i>Contacts: Ricky Wai Kei Chiu and Kristen Kayseas</i>	ISC representative sent an email thanking Dillon representatives for meeting that day and provided the Environmental Review Process Project Description Form. ISC representative noted that there would be a newer version of the form coming out and they would pass that along, when it becomes available.	April 19, 2022	Dillon representative thanked ISC representative and noted they would be in touch as the Project work progresses.
4.11	April 20, 2022	ISC <i>Contact: Kelley Blanchette on behalf of Hon. Patty Hadju (Minister of Indigenous Services Canada)</i>	Representative from the office of the Minister of ISC emailed Dillon representative to acknowledge receipt of their email correspondence dated February 28, 2022, requesting information regarding the requirements under the <i>Impact Assessment Act</i> for on-reserve projects in Ontario. The Minister's representative apologized for the delay in responding and thanked Dillon representative for writing. The Minister's representative noted that they were aware Dillon representatives had met with ISC officials on April 7 and that the ISC representatives had followed up with regional contacts to explain the <i>Impact Assessment Act</i> procedures. The Minister's representative wished Dillon representative success with their upcoming project.	N/A	N/A
4.12	April 21, 2022	ISC <i>Contacts: Ricky Wai Kei Chiu, Cynthia Brown, Kristen Kayseas, Julieta Werner, Selina Aivaliotis, Roger Dockstader, and Rebecca Leighfield</i>	Enbridge Gas representative, after discussing matters internally, stated that legal council does not believe the existing Development Permit needs to be amended, however, consent of both the Minister and the Tyendinaga Mohawk Council will be needed to construct, extend or relocate any works for the purpose of distribution as per the existing permit. The Enbridge Gas representative provided an attachment showing consent of the Tyendinaga Mohawk Council and inquired how to obtain the consent of the Minister. Enbridge Gas representative also asked if anyone could advise and confirm if a Project Description form still needed to be submitted or if the process could be considered complete since a new permit is not required.	April 21, 2022	ISC representative confirmed that a Project Description form along with a Section 82 determination under the <i>Impact Assessment Act</i> would still be required. This being a result of consent still being required from the Minister, and ISC still considered to be a Federal Authority in allowing the Project to be carried out. ISC representative noted that their colleague from the Land Unit would respond to inquiries related to the permit and the Minister's consent.

Line Item	Date of Consultation	Name of Agency and/or Contact	Description of Consultation Activity	Date of Response	Response and Issue Resolution (if applicable)
4.13	April 21, 2022	ISC <i>Contacts: Ricky Wai Kei Chiu, Cynthia Brown, Kristen Kayseas, Julieta Werner, Selina Aivaliotis, Roger Dockstader, and Rebecca Leighfield</i>	Enbridge Gas representative thanked ISC representative for their response and noted they would wait to hear from the Land Unit representative.	April 21, 2022	<p>ISC Land Unit representative responded, stating that Ministerial approval of construction, extension or relocation is defined in article 26 of the existing Development Permit. Per article 26(b), Union Gas is to deliver separate notices to both Tyendinaga Mohawk Council and the Minister. Each notice should contain the proposed construction, extension or relocation of any works for the purposes accompanied by a plan detailing the location and nature of the proposed construction, extension or relocation. When ISC is reviewing these types of requests, they are also ensuring that there is compliance with all applicable laws, including and not limited to the <i>Impact Assessment Act</i>. ISC also has to ensure that the proposed lines will not encroach on Certificate of Possession (CP) land and, if they do, that the CP holder's consent has been given.</p> <p>ISC Land Unit representative stated that when Enbridge Gas shares the plan detailing the location and nature of the proposed construction, extension or relocation, they ensure that it clearly shows the current lines vs. the proposed lines. They also noted that the Mohawk Council Resolution is almost 5 years old, so they will need confirmation that the Tyendinaga Mohawk Council is in agreement with the Band Council Resolution (BCR).</p> <p>Once ISC receives written notice as outlined in article 26(a), the Minister (or person with delegated authority) will make a determination of the request in writing.</p>
4.14	May 2, 2022	ISC <i>Contacts: Ricky Wai Kei Chiu and Kristen Kayseas</i>	Dillon representative sent Notice of Commencement via email.	N/A	N/A
4.15	June 13, 2022	ISC <i>Contacts: Ricky Wai Kei Chiu and Kristen Kayseas</i>	ISC representative followed up with Dillon representative to provide revised and most up-to-date version of the Environmental Review Process (ERP) Project Description Form.	June 13, 2022	Dillon representative thanked ISC representative for the new form and noted they would be sure to use the new form when they do their submission.
4.16	July 18, 2022	ISC <i>Contacts: Ricky Wai Kei Chiu and Kristen Kayseas</i>	Dillon representative emailed ISC representative to advise that the Environmental Report is being finalized and they are drafting the ERP Project Description Form. Dillon representative asked which sections of the form they are required to fill out.	July 18, 2022	ISC representative stated that the Dillon representative is to fill out the entire form for the Project and once the Project Description Form and supplemental report are available, the ISC will post the Project on the Canadian Impact Assessment Registry.
4.17	July 18, 2022	ISC <i>Contacts: Ricky Wai Kei Chiu and Kristen Kayseas</i>	Dillon representative emailed ISC representative to thank them and note that they will be in touch in the coming weeks.	October 31, 2022	Dillon representative emailed ISC representative to state that there is not enough space in Section 6 of the ERP Project Description Form for the potential environmental effects. Dillon representative asked how they should mitigate this.

Line Item	Date of Consultation	Name of Agency and/or Contact	Description of Consultation Activity	Date of Response	Response and Issue Resolution (if applicable)
4.18	October 31, 2022	ISC <i>Contacts: Ricky Wai Kei Chiu and Kristen Kayseas</i>	ISC representative advised that a separate document laying out the environmental effects and mitigation measures, in the same format as Section 6 of the form would be fine.	October 31, 2022	Dillon representative thanked ISC representative for the quick response and noted that they will follow the same format. Dillon representative asked if there was a list of criteria and definitions for the characterization of residual effects, like what is used in Canada Energy Regulator (CER) applications.
4.19	October 31, 2022	ISC <i>Contacts: Ricky Wai Kei Chiu and Kristen Kayseas</i>	ISC representative stated that they do not have a set standard for characterization criteria, but due to the similar nature of the Project to CER projects, those definitions can be applied as long as they are clearly defined.	November 1, 2022	Dillon representative advised that they will include a section on the assessment criteria in the separate document that they are putting together for Section 6.
4.20	February 14, 2023	ISC <i>Contacts: Ricky Wai Kei Chiu and Brian Studer</i>	Dillon representative advised that the Project Description Form will be drafted in a couple of weeks and asked if there were any reservations about Dillon reaching out to Environment and Climate Change Canada (ECCC) directly regarding Species at Risk.	February 14, 2023	ISC representative thanked Dillon representative for the notice about the Project Description Form. ISC representative advised that Dillon may proceed with notice to ECCC to kick-start the review timeline. ISC representative asked that they remain cc'd on correspondence with ECCC and requested Species at Risk permits be provided to ISC as well. ISC representative provided additional information on materials that should be included in Section 5 of the Project Description Form. ISC representative provided a new point of contact going forward and thanked Dillon representative.
4.21	February 15, 2023	ISC <i>Contacts: Ricky Wai Kei Chiu and Brian Studer</i>	Dillon representative thanked former ISC representative for the time they have worked together. Dillon representative welcomed the new ISC representative and requested that they reach out if they require additional information. Dillon representative noted they will be sure to include them on communications with ECCC.	N/A	N/A
4.22	March 30, 2023	ISC <i>Contacts: Brian Studer and Kristen Kayseas</i>	Dillon representative emailed ISC representative to provide the draft ERP Project Description Form.	N/A	N/A
4.23	April 12, 2023	ISC <i>Contacts: Brian Studer and Kristen Kayseas</i>	ISC representative reached out to Dillon representative inquiring whether ECCC had responded to their request for review of the SAR Investigation Memo. ISC representative noted that ECCC's comments would have tremendous relevance to their review of the ERP Project Description Form.	April 12, 2023	Dillon representative stated that they had not received any response from ECCC as of yet, but noted that they were planning to follow up again on April 13 to see if ECCC would acknowledge receipt of their email. Dillon representative stated that if they do not hear back from ECCC by the deadline of April 21, they would look into other contacts at ECCC that might be able to help. Dillon representative asked ISC representative if they have any ECCC contacts they would suggest.
4.24	April 12, 2023	ISC <i>Contacts: Brian Studer and Kristen Kayseas</i>	ISC representative stated that, while they were not sure of the exact person who should be contacted at ECCC, they recommended contacting two individuals that they were familiar with at ECCC, and noted that hopefully one of those individuals would be able to assist.	April 12, 2023	Dillon representative thanked ISC representative for the names of the ECCC contacts and noted they would include them on their correspondence when they reach out on April 13.

Line Item	Date of Consultation	Name of Agency and/or Contact	Description of Consultation Activity	Date of Response	Response and Issue Resolution (if applicable)
5.1	May 2, 2022	Transport Canada <i>Contact: Environmental Assessment Program, Ontario Region</i>	Dillon representative sent Project letter and Notice of Commencement via email.	May 16, 2022	Transport Canada stated that they do not require receipt of all individual or Class EA related notifications. They are requesting project proponents self-assess if the project: <ol style="list-style-type: none"> Will interact with a federal property and/or waterway by reviewing the Directory of Federal Real Property, available at www.tbs-sct.gc.ca/dfrp-rbif/; and Will require approval and/or authorization under any Acts administered by Transport Canada available at http://www.tc.gc.ca/eng/acts-regulations/menu.htm. <p>If the aforementioned does not apply, the Environmental Assessment program should not be included in any further correspondence and future notifications will not receive a response. If there is a role under the program, correspondence should be forwarded electronically to: EnviroOnt@tc.gc.ca with a brief description of Transport Canada's expected role.</p> <p>Transport Canada also provided a summary of the most common Acts that have applied to projects in an Environmental Assessment context.</p>
6.1	May 2, 2022	Environment and Climate Change Canada (ECCC) <i>Contact: Wes Plant</i>	Dillon representative sent Project letter and Notice of Commencement via email.	N/A	N/A
6.2	April 6, 2023	ECCC <i>Contact: Wes Plant</i>	Dillon representative emailed ECCC representative to provide the Species at Risk (SAR) Habitat Assessment and Summary Memo and requested feedback by April 21, 2023.	April 13, 2023	Dillon representative followed up to their previous email to see if ECCC representative could acknowledge receipt of the memo and their request for review.
6.3	April 13, 2023	ECCC <i>Contact: Ravi Patel</i>	ECCC representative noted that they are currently reviewing the SAR memo and requested additional information regarding timing of Project construction.	April 13, 2023	Dillon representative thanked ECCC representative. Dillon representative stated that construction is anticipated to begin in July 2023 and be completed by the end of December 2023. Dillon representative provided a link to the Environmental Report on the Enbridge Gas website.
7.1	May 2, 2022	Fisheries and Oceans Canada (DFO) <i>Contact: Fish and Fish Habitat Protection Program</i>	Dillon representative sent Project letter and Notice of Commencement via email.	May 2, 2022	Automatic reply stating that message was received and that a response would be provided as soon as possible.
7.2	May 2, 2022	DFO <i>Contact: Kyle Mataya</i>	DFO representative responded stating that the Department reviews projects that are conducted in or near waterbodies that support fish along with project proposals that impact Species at Risk. DFO representative stated that Dillon representative should visit the DFO website (link provided in email) for further information to determine if the Project requires a Request for Review Form to be submitted.	N/A	N/A

Line Item	Date of Consultation	Name of Agency and/or Contact	Description of Consultation Activity	Date of Response	Response and Issue Resolution (if applicable)
PROVINCIAL AGENCIES AND ELECTED OFFICIALS					
8.1	May 2, 2022	Member of Provincial Parliament Hastings – Lennox and Addington <i>Contacts: Daryl Kramp, Denise Grey</i>	Enbridge representative provided the Notice of Commencement via email.	N/A	N/A
9.1	May 2, 2022	Ministry of Municipal Affairs and Housing (MMAH) <i>Contact: Erick Boyd</i>	Dillon representative sent Project letter and Notice of Commencement via email.	N/A	N/A
10.1	May 2, 2022	Ministry of Northern Development, Mines, Natural Resources and Forestry (NDMNRF) <i>Contact: Catherine Warren</i>	Dillon representative sent Project letter and Notice of Commencement via email.	N/A	N/A
11.1	May 2, 2022	Ministry of Energy (MOE) <i>Contact: Andrea Pastori</i>	Dillon representative sent Project letter and Notice of Commencement via email.	N/A	N/A
12.1	May 2, 2022	Ministry of Environment, Conservation and Parks (MECP) <i>Contacts: Cathy Chisholm (Belleville Area Office); Trevor Dagalil and Roberto Sacilotto (Kingston District Office); Sarah Paul and Sandra Gram (Environmental Assessment & Permissions Division); Kirsten Corrigan and Jennifer Moulton (Conservation & Source Protection Branch); Paul Heeney (SAR Branch), SAR Branch Coordinator, and SAR Ontario (Permitting & Compliance)</i>	Dillon representative sent Project letter and Notice of Commencement via email.	May 6, 2022	MECP representative from Conservation and Source Protection Branch provided information on drinking water and natural gas pipelines for consideration in the Environmental Report.
13.1	May 2, 2022	Ministry of the Solicitor General <i>Contact: Robert Greene</i>	Dillon representative sent Project letter and Notice of Commencement via email.	N/A	N/A
14.1	May 2, 2022	Ministry of Agriculture, Food and Rural Affairs (OMAFRA) <i>Contacts: EA Notices, Jocelyn Beatty</i>	Dillon representative sent Project letter and Notice of Commencement via email.	N/A	N/A
15.1	May 2, 2022	Ministry of Citizenship and Multiculturalism (MCM) <i>Contact: Jack Mallon</i>	Dillon representative sent Project letter and Notice of Commencement via email.	June 6, 2022	MCM representative provided a letter of advice regarding the proposed Project.
15.2	June 7, 2022	MCM <i>Contacts: Jack Mallon, Karla Barboza, and Zora Crnojacki (OEB)</i>	Dillon representative thanked MCM representative for the letter of advice.	N/A	N/A
15.3	December 6, 2022	MCM <i>Contact: Karla Barboza</i>	Dillon representative (TMHC) provided MCM representative with the Cultural Heritage Assessment Report for the Project and noted that they look forward to MCM's comments.	N/A	N/A

Line Item	Date of Consultation	Name of Agency and/or Contact	Description of Consultation Activity	Date of Response	Response and Issue Resolution (if applicable)
15.4	January 13, 2023	MCM <i>Contact: Joseph Harvey on behalf of Karla Barboza</i>	<p>MCM representative provided a letter outlining their comments on the Cultural Heritage Assessment Report. They noted the report should be called “Cultural Heritage Report: Existing Conditions and Preliminary Impact Assessment” and provided the following comments:</p> <ul style="list-style-type: none"> • A new section should be included providing a brief summary of the groups and individuals who were engaged, how and when community engagement was undertaken and the results of the engagement, including responses, comments or concerns expressed and how these were considered (a detailed summary can be attached as an appendix). • Please clarify whether Indigenous communities and/or heritage organizations were (or will be) contacted. • Section 4 (Heritage Screening and Evaluation) – It is unclear why 197 properties were screened for potential CHVI. It seems as though the majority of the identified properties were evaluated due to being 40+ years old. Please note that 40+ year old buildings or structures do not necessarily hold CHVI; their age simply indicates a higher potential. Professional judgement and understanding of the development of the area should also be applied. • It is not appropriate to use O. Reg. 9/06 as investigative criteria without doing detailed background research. The field program can identify all known or potential built heritage resources or cultural heritage landscapes in the study area, based on research, the screening checklist Criteria for Evaluating Potential for Built Heritage Resources and Cultural Heritage Landscapes, historical summary of the development of the area and professional judgement. • Please note that Table 2 of Section 8 (Impact Assessment and Proposed Mitigations) will need to be revised to incorporate any changes made to Section 4. <p>Section 8 (Impact Assessment and Proposed Mitigations) Table 2 – Any Heritage Impact Assessments undertaken should be circulated for review and comment to MCM, a member of the Township of Tyendinaga and County of Hastings planning staff, local Indigenous communities and be made available to local organizations or individuals who have expressed interest in review. For consistency with current legislation and terminology please replace the term “character defining elements” with “potential heritage attributes”. Heritage attributes contribute to the cultural heritage value or interest of a property.</p>	January 31, 2023	<p>Dillon representative (TMHC) thanked MCM representative for their comments and noted that all reports would be titled “Cultural Heritage Report: Existing Conditions and Preliminary Impact Assessment” going forward.</p> <p>Dillon representative (TMHC) clarified that the O. Reg. 9/06 criteria were only applied in a high-level and preliminary fashion and it is not intended to represent a realized O. Reg. 9/06 evaluation, but instead a demonstrable and familiar way of communicating how professional judgement has been applied. Dillon representative (TMHC) also noted that the 40+ year old criteria is one of several (e.g., potential cultural heritage landscapes, bridges, municipal heritage registers, plaques, regional development history, etc.) used to help inform which properties may need a bit more professional judgement than others. Dillon representative (TMHC) asked whether that was sufficient explanation for their logic and noted their approach to address the comments from MCM would be to further clarify the text in the report and to specify that full application of O. Reg. 9/06 is required as part of any subsequent heritage impact assessments.</p> <p>Dillon representative (TMHC) inquired whether MCM had produced any more specific EA-related heritage policy documents (outside of the screening checklist, Ontario Heritage Toolkit and the Standards and Guidelines for Provincial Heritage Properties) that could be referenced in the future or if something was in the works.</p>

Line Item	Date of Consultation	Name of Agency and/or Contact	Description of Consultation Activity	Date of Response	Response and Issue Resolution (if applicable)
15.5	February 3, 2023	MCM <i>Contact: Joseph Harvey on behalf of Karla Barboza</i>	MCM representative thanked Dillon representative (TMHC) for clarifying their approach and noted that they look forward to reviewing the revised document. MCM representative stated that updates are anticipated to the Ontario Heritage Tool Kit, Provincial Policy Statement guidance, and the OEB environmental guidelines, however, they are unable to confirm the timelines for any of these updates. MCM representative stated that their standard advice for OEB projects was included as part of their initial letter (dated June 6, 2022), however, they would be happy to provide some additional examples to assist with Project reporting, if needed.	N/A	N/A
16.1	May 2, 2022	Ministry of Transportation (MTO) <i>Contact: Alexandre Gitkow</i>	Dillon representative sent Project letter and Notice of Commencement via email.	May 10, 2022	MTO representative provided a letter of comment regarding the Project. The letter noted that the proposed Project falls mostly outside MTO jurisdiction and/or property, with the exception of the following two areas that will require permits: <ul style="list-style-type: none"> • The area at the intersection of York Road and Highway 49, in the northwest corner, where Enbridge Gas plans to connect and rebuild the station; • At the corner of Highway 49 and Lower Slash Road where it looks like Enbridge Gas will connect to an existing pipe that runs parallel to the Highway. The letter concluded that if the project scope or route change, that MTO would like the chance to review and comment again.
16.2	May 12, 2022	MTO <i>Contacts: Alexandre Gitkow, Kate Green, Prabin Sharma, Muhammed Waseem, Darren Cizmar, Brenda Johnston, Amanda Rodek</i>	Dillon representative thanked MTO representative for their letter and comments on the Project. Dillon representative noted that Enbridge Gas understands the need for MTO permits for Project work around Highway 49 and that someone from Enbridge Gas will be in touch once the detailed designs are developed to obtain the necessary permits for Project construction in these areas.	N/A	N/A
16.3	August 16, 2022	MTO <i>Contact: Alexandre Gitkow</i>	MTO representative provided their comments on the Environmental Report which included details on permitting and next steps.	August 16, 2022	Enbridge Gas advised that they will be in touch when they are in the design stage of the Project.
17.1	May 2, 2022	Quinte Conservation <i>Contact: Sam Carney</i>	Dillon representative sent Project letter and Notice of Commencement via email.	N/A	N/A
17.2	August 12, 2022	Quinte Conservation <i>Contact: Sam Carney</i>	Enbridge Gas representative sent the link to the Environmental Report and requested all feedback be provided by September 30, 2022.	N/A	N/A
17.3	October 31, 2022	Quinte Conservation <i>Submission Portal</i>	Dillon Representative submitted an inquiry for Quinte Conservation's jurisdiction in relation to the Tyendinaga Mohawk Territory.	October 31, 2022	Automatic reply acknowledging receipt of email to Quinte Conservation.

Line Item	Date of Consultation	Name of Agency and/or Contact	Description of Consultation Activity	Date of Response	Response and Issue Resolution (if applicable)
17.4	November 2, 2022	Quinte Conservation Contact: Paul McCoy	Planning and Regulations Manager stated that O. Reg. 319/09 which enforces regulation near wetlands, lakes and streams does not apply to the Mohawk Territory and Federal legislation applies. Planning and Regulations Manager noted that staff from the Territory often ask for advice and Quinte Conservation will perform inspections upon request.	November 2, 2022	Dillon Representative thanked the Planning and Regulations manager for their response and noted that they will reach out if they have any further questions.
17.5	January 23, 2023	Quinte Conservation Contact: Paul McCoy	Dillon Representative emailed the Planning and Regulations Manager to note that approximately 60 m of the preliminary preferred route is within Quinte Conservation jurisdiction. Dillon representative noted that based on their understanding, Section 28 of the Act (formerly subsection 2 (1) of O. Reg. 319/09 was replaced with Schedule 4, Part VI, Section 28 of O. Reg. 319/09, meaning that a permit from Quinte Conservation is not required and asked the Planning and Regulations Manager to confirm.	January 25, 2023	Planning and Regulations Manager stated that although some areas are within Quinte Conservation jurisdiction, a permit is not required and stated that there has been no changes to O. Reg. 319/09.
17.6	January 25, 2023	Quinte Conservation Contact: Paul McCoy	Dillon representative thanked the Planning and Regulations Manager for clarifying.	N/A	N/A
18.1	May 2, 2022	Hydro One Networks Inc. Contact: Secondary Land Use Program	Dillon representative sent Project letter and Notice of Commencement via email.	N/A	N/A
ONTARIO PIPELINE COORDINATING COMMITTEE (OPCC)					
19.1	May 2, 2022	OPCC – OEB Representative Contact: Zora Cmojacki	Dillon representative sent Project letter and Notice of Commencement via email.	N/A	N/A
19.2	August 12, 2022	OPCC – OEB Representative Contact: Zora Cmojacki	Enbridge Gas representative sent the link to the Environmental Report and requested all feedback be provided by September 30, 2022.	N/A	N/A
20.1	May 2, 2022	OPCC – OMAFRA Representative Contact: Helma Geerts	Dillon representative sent Project letter and Notice of Commencement via email.	N/A	N/A
20.2	August 12, 2022	OPCC – OMAFRA Representative Contact: Helma Geerts	Enbridge Gas representative sent the link to the Environmental Report and requested all feedback be provided by September 30, 2022.	N/A	N/A
21.1	May 2, 2022	OPCC – MECP Representative Contacts: Katy Potter, Jon Orpana	Dillon representative sent Project letter and Notice of Commencement via email.	May 2, 2022	OPCC MECP representative (Katy Potter) forwarded Dillon representative's email to a different MECP representative (Jon Orpana) who responded to the notice requesting shape files so that their GIS Officer could put together a series of maps for the preliminary preferred route. MECP representative noted that they use the maps to conduct an internal preliminary review for the District Office, SAR Branch, and Source Protection staff.
21.2	May 2, 2022	OPCC – MECP Representative Contact: Jon Orpana	MECP representative called Dillon representative inquiring about the regulatory process of the Project, given its location on federal lands, and asked if any part of the Project was outside the Tyendinaga Mohawk Territory. Dillon representative told MECP representative that the OEB process still applies and there are portions of the Project in Shannonville, outside the federal lands of the Reserve. Dillon representative noted that shape files would be provided soon.	May 2, 2022	Dillon representative emailed MECP representative thanking them for reaching out and provided the shape files for the Project pipeline routing and station location.

Line Item	Date of Consultation	Name of Agency and/or Contact	Description of Consultation Activity	Date of Response	Response and Issue Resolution (if applicable)
21.3	May 2, 2022	OPCC – MECP Representative Contact: Jon Orpana	MECP representative thanked Dillon representative for their quick reply.	N/A	N/A
21.4	August 12, 2022	OPCC – MECP Representative Contact: Katy Potter	Enbridge Gas representative sent the link to the Environmental Report and requested all feedback be provided by September 30, 2022.	N/A	N/A
21.5	March 2, 2023	OPCC – MECP Representative Contacts: Katy Potter, Jon Orpana	Dillon representative emailed MECP representative to request their input on the Species at Risk Habitat Assessment and Summary Memo by March 17, 2023.	March 2, 2023	MECP representative advised that they changed positions within the MECP and cc'd the new Project Review Unit Supervisor (Gavin Battarino).
21.6	March 2, 2023	OPCC – MECP Representative Contacts: Katy Potter, Jon Orpana	Dillon representative thanked MECP representative for letting them know.	N/A	N/A
21.7	March 13, 2023	OPCC – MECP Representative Contacts: Gavin Battarino, Jon Orpana	Dillon representative sent the Species at Risk Habitat Assessment and Summary Memo to the new MECP Project Review Supervisor and asked if they would be able to provide comments by March 17, 2023.	March 13, 2023	Automatic reply from MECP Project Review Unit Supervisor advising to reach out to Trevor Bell in their absence. Dillon representative forwarded email to Trevor Bell.
21.8	March 13, 2023	OPCC – MECP Representative Contact: Jon Orpana	MECP representative emailed Dillon representative to note that MECP Regional Planners do not have the training to review materials related to Species at Risk and noted that it is customary for Enbridge Gas to circulate these materials to the Species at Risk enquiry inbox.	March 14, 2023	MECP representative followed up to their previous email to note that the Species at Risk biologist is off for March Break and likely will not review the materials until the end of the month. MECP representative noted that they provided the Species at Risk Biologist the shapefiles at the Notice of Commencement stage so the memo should not be a surprise to them. MECP representative stated that the Species at Risk Branch and Source Protection Branch are usually circulated project notices.
21.9	March 14, 2023	OPCC – MECP Representative Contact: Jon Orpana	Dillon representative thanked the MECP representative for the additional information. Dillon representative noted that the Notice of Commencement was forwarded to the Source Protection Branch and Species at Risk Branch, however, the memo was not. Dillon representative asked if the MECP representative had forwarded the memo to the Species at Risk Branch on Dillon's behalf.	March 14, 2023	MECP representative noted that Trevor Bell is filling in for Gavin Battarino while they are on vacation, but the biologist is away for March Break so no review will occur until the biologist returns. MECP representative advised that they did forward the Species at Risk Habitat Assessment and Summary Memo to the Species at Risk Branch.
21.10	March 14, 2023	OPCC – MECP Representative Contact: Jon Orpana	Dillon representative thanked MECP representative.	N/A	N/A
21.11	April 6, 2023	OPCC – MECP Representative Contacts: Gavin Battarino, Jon Orpana	Dillon representative emailed MECP representative to follow up on the review of the Species at Risk Habitat Assessment and Summary Memo and asked if comments could be provided by April 14, 2023. Dillon representative asked that if the timeline does not work for MECP, that MECP provide an anticipated timeline for their comments.	N/A	N/A
22.1	May 2, 2022	OPCC – Technical Standards and Safety Authority (TSSA) Representative Contact: Kourosh Manouchehri	Dillon representative sent Project letter and Notice of Commencement via email.	N/A	N/A

Line Item	Date of Consultation	Name of Agency and/or Contact	Description of Consultation Activity	Date of Response	Response and Issue Resolution (if applicable)
22.2	August 12, 2022	OPCC – TSSA Representative Contact: Kourosh Manouchehri	Enbridge Gas representative sent the link to the Environmental Report and requested all feedback be provided by September 30, 2022.	August 15, 2022	The TSSA representative emailed Enbridge Gas representative to thank them for the information and state that an Application for Review of a Pipeline Project needs to be filled out as part of the Ontario Pipeline Coordinating Committee.
22.3	August 15, 2022	OPCC – TSSA Representative Contact: Kourosh Manouchehri	Enbridge Gas representative thanked them for the information and advised that they will fill out the application.	N/A	N/A
22.4	April 6, 2023	OPCC – TSSA Representative Contacts: Fuels Safety Submissions and Licensing and Registration	Enbridge Gas representative submitted an Application for Review of Pipeline Project to the TSSA. Enbridge Gas representative noted pre-payment had been submitted.	N/A	N/A
23.1	May 2, 2022	OPCC – MMAH Representative Central Municipal Services Office Contact: Maya Harris	Dillon representative sent Project letter and Notice of Commencement via email.	N/A	N/A
23.2	August 12, 2022	OPCC – MMAH Representative Central Municipal Services Office Contact: Maya Harris	Enbridge Gas representative sent the link to the Environmental Report and requested all feedback be provided by September 30, 2022.	N/A	N/A
24.1	May 2, 2022	OPCC – MMAH Representative Municipal Services Office – North Contact: Bridget Schulte-Hostedde	Dillon representative sent Project letter and Notice of Commencement via email.	N/A	N/A
24.2	August 12, 2022	OPCC – MMAH Representative Municipal Services Office – North Contact: Bridget Schulte-Hostedde	Enbridge Gas representative sent the link to the Environmental Report and requested all feedback be provided by September 30, 2022.	N/A	N/A
25.1	May 2, 2022	OPCC – MMAH Representative Eastern Municipal Services Office Contact: Mike Elms	Dillon representative sent Project letter and Notice of Commencement via email.	N/A	N/A
25.2	August 12, 2022	OPCC – MMAH Representative Eastern Municipal Services Office Contact: Mike Elms	Enbridge Gas representative sent the link to the Environmental Report and requested all feedback be provided by September 30, 2022.	N/A	N/A
26.1	May 2, 2022	OPCC – MOE Representative Contact: Jonathon Wilkinson	Dillon representative sent Project letter and Notice of Commencement via email.	May 2, 2022	Auto-reply message stating the MOE representative is no longer with the Ministry and to contact the Indigenous Energy Policy Manager (Amy Gibson).
26.2	May 2, 2022	OPCC – MOE Representative Contact: Amy Gibson	Dillon representative sent Project letter and Notice of Commencement via email.	N/A	N/A
26.3	August 12, 2022	OPCC – MOE Representative Contact: Amy Gibson	Enbridge Gas representative sent the link to the Environmental Report and requested all feedback be provided by September 30, 2022.	N/A	N/A
27.1	May 2, 2022	OPCC – MCM Representative Contact: Karla Barboza	Dillon representative sent Project letter and Notice of Commencement via email.	N/A	N/A

Line Item	Date of Consultation	Name of Agency and/or Contact	Description of Consultation Activity	Date of Response	Response and Issue Resolution (if applicable)
27.2	August 12, 2022	OPCC – MCM Representative <i>Contact: Karla Barboza</i>	Enbridge Gas representative sent the link to the Environmental Report and requested all feedback be provided by September 30, 2022.	N/A	N/A
27.3	September 28, 2022	OPCC – MCM Representative <i>Contact: Laura Hatcher on behalf of Karla Barboza</i>	MCM representative provided comments on the Environmental Report relating to archaeological resources, built heritage, and environmental inspectors and monitors.	September 28, 2022	Enbridge Gas representative provided responses to MCM representative's comments. Enbridge Gas stated that they plan to have Indigenous review of the Stage 1 Archaeological Assessment (AA) to allow comments during the OPCC review. The goal is to capture all stakeholder comments before submitting the Final Environmental Report to the OEB or the Stage 1 AA to MCM. Enbridge Gas representative stated that a Cultural Heritage Screening Checklist was completed for the Project and indicated that a Cultural Heritage Assessment Report (CHAR) is required and any recommendations from the CHAR will be included in the Environmental Protection Plan. Enbridge Gas representative acknowledged the comment regarding archaeologists only be employed to monitor impacts to archaeological resources.
27.4	October 18, 2022	OPCC – MCM Representative <i>Contact: Laura Hatcher on behalf of Karla Barboza</i>	MCM representative thanked Enbridge Gas representative for their response. MCM representative stated that they advise the Stage 1 AA should be reviewed by the Ministry and accepted onto the <i>Ontario Public Register of Archaeological Reports</i> prior to the completion of the Environmental Report. MCM also recommended that the CHAR be completed at this stage to inform the Environmental Report.	October 25, 2022	Enbridge Gas representative noted that it allows Indigenous communities to review and comment prior to the submission to MCM and mitigates Project risk. Enbridge Gas representative noted that all mitigation, commitments, and recommendations for the Project make it into the Environmental Protection Plan and stated that, at times, it is not feasible to complete a CHAR as part of the Environmental Assessment process. Enbridge Gas representative noted that, if time permits, they intend to provide archaeological and cultural heritage reports prior to Environmental Report submission.
28.1	May 2, 2022	OPCC – NDMNRF Representative <i>Contact: Keith Johnston</i>	Dillon representative sent Project letter and Notice of Commencement via email.	N/A	N/A
28.2	August 12, 2022	OPCC – NDMNRF Representative <i>Contact: Keith Johnston</i>	Enbridge Gas representative sent the link to the Environmental Report and requested all feedback be provided by September 30, 2022.	N/A	N/A
29.1	May 2, 2022	OPCC – Infrastructure Ontario Representative <i>Contact: Cory Ostrowka</i>	Dillon representative sent Project letter and Notice of Commencement via email.	N/A	N/A
29.2	August 12, 2022	OPCC – Infrastructure Ontario Representative <i>Contact: Cory Ostrowka</i>	Enbridge Gas representative sent the link to the Environmental Report and requested all feedback be provided by September 30, 2022.	N/A	N/A
30.1	May 2, 2022	OPCC – MTO Representative <i>Contacts: Tony DiFabio, Amanda Rodek</i>	Dillon representative sent Project letter and Notice of Commencement via email.	May 24, 2022	MTO representative responded with letter from MTO East Region (Alexandre Gitkow) dated May 10, 2022.
30.2	May 26, 2022	OPCC – MTO Representative <i>Contact: Amanda Rodek</i>	Dillon representative thanked MTO representative for their response on behalf of MTO OPCC representative Tony DiFabio, noting they had received the letter from MTO East Region on May 10, 2022.	N/A	N/A

Line Item	Date of Consultation	Name of Agency and/or Contact	Description of Consultation Activity	Date of Response	Response and Issue Resolution (if applicable)
30.3	August 12, 2022	OPCC – MTO Representative <i>Contact: Tony DiFabio</i>	Enbridge Gas representative sent the link to the Environmental Report and requested all feedback be provided by September 30, 2022.	N/A	N/A
30.4	August 25, 2022	OPCC – MTO Representative <i>Contact: Amanda Rodek on behalf of Tony DiFabio</i>	MTO representative emailed Enbridge Gas to provide their feedback on the Environmental Report.	August 25, 2022	Enbridge Gas representative thanked MTO representative for their email and advised that they had received a response from a different representative at MTO (Alexandre Gitkow) on August 16, 2022. Enbridge Gas representative noted that they acknowledge the MTO representative's submission and confirm that Enbridge Gas will keep in touch with the MTO as the Project progresses through detailed design.
MUNICIPAL AGENCIES AND ELECTED OFFICIALS					
31.1	March 8, 2022	Township of Tyendinaga <i>Contacts: Carla Preston (Tyendinaga Township CAO) and Township Council</i>	Enbridge representative emailed Township of Tyendinaga to provide notice that the Township of Tyendinaga and the Mohawks of the Bay of Quinte were successful in securing funding for natural gas distribution and asked if they were available for a meeting to discuss the Project further.	March 9, 2023	Township of Tyendinaga noted that the upcoming Council meetings are on March 21 and April 4, 2022 and asked which meeting worked best for Enbridge.
31.2	March 11, 2022	Township of Tyendinaga <i>Contact: Carla Preston (Tyendinaga Township CAO)</i>	Enbridge representative emailed Township of Tyendinaga to state that they are available for a meeting on April 4 and asked if the meeting would be in-person.	March 22, 2022	Enbridge representative provided a reminder that Enbridge is available to present to Council on April 4.
31.3	March 28, 2022	Township of Tyendinaga <i>Contact: Carla Preston (Tyendinaga Township CAO)</i>	Township of Tyendinaga apologized for the delayed response and asked if they could schedule a call to provide background on the Project prior to the Council meeting. They noted that the Reeve will be absent from this meeting and asked if Enbridge could attend the following meeting.	March 29, 2022	Enbridge representative stated that they would be happy to provide background information the Project prior to the meeting with Council and asked for dates that work for them. Enbridge representative noted that they would attend the Council meeting when the Reeve returns. Enbridge representative asked for the date and time of that meeting.
31.4	April 6, 2022	Township of Tyendinaga <i>Contact: Carla Preston (Tyendinaga Township CAO)</i>	Enbridge representative asked if Township of Tyendinaga if they had time next week to discuss the Project.	April 7, 2022	Township of Tyendinaga emailed Enbridge representative to ask if Monday, April 11, 2022 worked for them.
31.5	April 12, 2022	Township of Tyendinaga <i>Contact: Carla Preston (Tyendinaga Township CAO)</i>	Enbridge representative apologized for the delayed response and asked Township of Tyendinaga if they had time after the Easter weekend to connect via Zoom.	April 13, 2022	Township of Tyendinaga proposed April 20, 2022 at 11 am for the meeting.
31.6	April 13, 2022	Township of Tyendinaga <i>Contact: Carla Preston (Tyendinaga Township CAO)</i>	Enbridge representative agreed to the proposed meeting date and time. Enbridge representative noted that they would send a meeting invite.	April 19, 2022	Enbridge representative emailed Township of Tyendinaga to note that they need to revise the meeting date and time and suggested April 22, 2022 at 10 am.
31.7	April 21, 2022	Township of Tyendinaga <i>Contact: Carla Preston (Tyendinaga Township CAO)</i>	Township of Tyendinaga agreed to the new meeting date and time. They asked if the Reeve should attend as well.	April 21, 2022	Enbridge representative stated that this meeting will provide background and then they can arrange a delegation to Council.
31.8	April 21, 2022	Township of Tyendinaga <i>Contact: Carla Preston (Tyendinaga Township CAO)</i>	Township of Tyendinaga agreed to the proposed meeting schedule.	April 21, 2022	Enbridge representative emailed the Township of Tyendinaga to provide a meeting invite for April 22, 2022.

Line Item	Date of Consultation	Name of Agency and/or Contact	Description of Consultation Activity	Date of Response	Response and Issue Resolution (if applicable)
31.9	April 22, 2022	Township of Tyendinaga <i>Contact: Carla Preston (Tyendinaga Township CAO)</i>	Enbridge representative thanked Township of Tyendinaga for the meeting and provided a letter of support from the Township of Alnwick/Haldimand for their reference. Enbridge representative noted that the Ministry of Energy is planning a press release for the Project on April 26, 2022.	N/A	N/A
31.10	April 28, 2022	Township of Tyendinaga <i>Contact: Carla Preston (Tyendinaga Township CAO)</i>	Enbridge representative asked if the May 2 presentation to Council was still occurring as scheduled and noted if the date or time needed to be revised, Enbridge can accommodate.	April 28, 2022	Township of Tyendinaga noted that the May 2 delegation is still planned and asked for the names of attendees for the agenda. Township of Tyendinaga asked if a PowerPoint presentation will be used during the meeting and provided the Zoom meeting link.
31.11	April 28, 2022	Township of Tyendinaga <i>Contact: Carla Preston (Tyendinaga Township CAO)</i>	Enbridge representative thanked Township of Tyendinaga for confirming the meeting date and asked the time the meeting was scheduled for. Enbridge representative noted that they will use the same slide deck previously used in the background presentation meeting and provided a list of attendees.	N/A	N/A
31.12	May 2, 2022	Township of Tyendinaga <i>Contact: Carla Preston (Tyendinaga Township CAO)</i>	Dillon representative sent Project letter and Notice of Commencement via email.	N/A	N/A
31.13	May 2, 2022	Township of Tyendinaga <i>Contact: Carla Preston (Tyendinaga Township CAO)</i>	Township of Tyendinaga noted that the announcement only included Mohawks of the Bay of Quinte (MBQ) and it may be brought up at the meeting that evening.	May 2, 2022	Enbridge representative noted that they were not aware that only MBQ was listed and they will work with the MPP to bring it to their attention. Enbridge representative asked what time Council was meeting that night.
31.14	May 2, 2022	Township of Tyendinaga <i>Contact: Carla Preston (Tyendinaga Township CAO)</i>	Township of Tyendinaga stated that the meeting is at 5 pm and asked if Enbridge representative had registered for the meeting yet.	May 2, 2022	Enbridge representative apologised and stated that they were not aware that they needed to register for the meeting and asked for the registration link.
31.15	May 2, 2022	Township of Tyendinaga and Hastings County <i>Contacts: Rick Phillips (Hastings County Warden/Township of Tyendinaga Reeve), Carla Preston (Tyendinaga Township CAO), and Township Council</i>	Enbridge representative met with Hastings County Warden/Township of Tyendinaga Reeve (Rick Phillips), as well as the CAO (Carla Preston) and Council members of the Township of Tyendinaga at the delegation on Monday, May 2, 2022 and provided information on the proposed Project.	N/A	N/A
31.16	May 3, 2022	Township of Tyendinaga <i>Contact: Carla Preston (Tyendinaga Township CAO)</i>	Enbridge representative sent a note that the meeting with Council went well and they look forward to working with the Township.	May 3, 2022	Township of Tyendinaga thanked Enbridge representative for the kind words and noted that they are working on a letter of support from Council.
31.17	May 3, 2022	Township of Tyendinaga <i>Contact: Carla Preston (Tyendinaga Township CAO)</i>	Enbridge representative thanked Township of Tyendinaga and noted to reach out if they need anything.	N/A	N/A
31.18	May 4, 2022	Township of Tyendinaga <i>Contact: Carla Preston (Tyendinaga Township CAO)</i>	Township of Tyendinaga requested the presentation slides from the Council meeting so that it can be forwarded to Council members.	May 4, 2022	Enbridge representative provided the slide deck from the Council meeting and requested to be cc'd on the email distribution.
31.19	May 4, 2022	Township of Tyendinaga <i>Contacts: Carla Preston (Tyendinaga Township CAO) and Township Council</i>	Township of Tyendinaga Township emailed Council to provide the slide deck and cc'd Enbridge representative.	N/A	N/A

Line Item	Date of Consultation	Name of Agency and/or Contact	Description of Consultation Activity	Date of Response	Response and Issue Resolution (if applicable)
31.20	May 4, 2022	Township of Tyendinaga and Hastings County <i>Contacts: Rick Phillips (Hastings County Warden/Township of Tyendinaga Reeve), Carla Preston (Tyendinaga Township CAO), and Township Council</i>	Enbridge representative followed up with the Hastings County and Township of Tyendinaga municipal officials thanking them for the opportunity to participate in the delegation on May 2 and provided the Project letter and Notice of Commencement as an attachment.	N/A	N/A
31.21	September 7, 2022	Township of Tyendinaga <i>Contact: Carla Preston (Tyendinaga Township CAO)</i>	Enbridge representative advised that they are aiming to file the OEB Leave-to-Construct Application on October 21. They asked if the letter of support could be forwarded again.	September 12, 2022	Township of Tyendinaga emailed to note that they will review some things and provide a response at a later time.
31.22	September 12, 2022	Township of Tyendinaga <i>Contact: Carla Preston (Tyendinaga Township CAO)</i>	Enbridge representative thanked the Township of Tyendinaga, noting they are aware that it is a busy time for them.	N/A	N/A
31.23	September 8, 2022	Township of Tyendinaga <i>Contact: Carla Preston (Tyendinaga Township CAO)</i>	Enbridge representative stated that the Project team will be at the Fall Fair on September 9 and 10, 2022 to answer questions about the Project. Enbridge representative noted that the market research survey will occur from September 12 to 13, 2022 and attached a copy of the survey for reference.	September 20, 2022	Township of Tyendinaga provided the letter of support and asked if the market research survey was complete.
31.24	September 23, 2022	Township of Tyendinaga <i>Contact: Carla Preston (Tyendinaga Township CAO)</i>	Enbridge representative thanked Township of Tyendinaga for the letter of support. Enbridge representative noted that the marketing survey was complete and requested a meeting to update Council on the Project.	N/A	N/A
31.25	October 20, 2022	Township of Tyendinaga <i>Contact: Carla Preston (Tyendinaga Township CAO)</i>	Enbridge representative emailed Township of Tyendinaga to ask for a municipal contact that can provide additional information for permitting regarding the planning and execution of the pipeline installation.	N/A	N/A
31.26	October 25, 2022	Township of Tyendinaga <i>Contact: Carla Preston (Tyendinaga Township CAO)</i>	Enbridge representative stated that they are looking to validate 911 addresses and wanted to confirm if they are within the scope.	October 26, 2022	Township of Tyendinaga noted that in regards to the 911 addresses request, the owners names and addresses are protected under the <i>Municipal Freedom of Information and Protection of Privacy Act (MFIPPA)</i> and as such are not to be disclosed to third parties, also this request is not an internal planning activity of the municipality therefore is not permitted under the Municipal License Agreement for Municipal Connect. Township of Tyendinaga provided some documents to help with understanding the legislative protections and obligations of MPAC under the Assessment Act and MFIPPA.
31.27	October 26, 2022	Township of Tyendinaga <i>Contact: Carla Preston (Tyendinaga Township CAO)</i>	Enbridge representative thanked them for the information and noted that they would share it internally. Enbridge representative asked when Township of Tyendinaga are available for lunch.	October 26, 2022	Enbridge representative asked if they were available for lunch on November 14, 2022. Enbridge representative noted that the Operations team needs to know the official town names on the 911 addresses.
31.28	October 26, 2022	Township of Tyendinaga <i>Contact: Carla Preston (Tyendinaga Township CAO)</i>	Township of Tyendinaga agreed to the lunch date and provided additional information on their office location.	N/A	N/A

Line Item	Date of Consultation	Name of Agency and/or Contact	Description of Consultation Activity	Date of Response	Response and Issue Resolution (if applicable)
31.29	January 17, 2023	Township of Tyendinaga Contact: Carla Preston (Tyendinaga Township CAO)	Enbridge representative suggested that they meet for breakfast on Monday prior to the ROMA. They also noted through discussions with the Reeve that Enbridge would be please to support the construction/development of a community splash pad and provided instructions on the application submission process.	January 17, 2023	Township of Tyendinaga asked if the application was through email or formal letter.
31.30	February 24, 2023	Township of Tyendinaga Contact: Carla Preston (Tyendinaga Township CAO)	Township of Tyendinaga noted that they are finishing up the application and asked if the Enbridge representative had some time to discuss.	N/A	N/A
31.31	January 22, 2023	Township of Tyendinaga Contact: Carla Preston (Tyendinaga Township CAO)	Enbridge representative asked Township of Tyendinaga if the Mayor and CAO were available for breakfast on January 23, 2023.	January 23, 2023	Township of Tyendinaga asked if lunch at noon would work.
31.32	January 23, 2023	Township of Tyendinaga Contact: Carla Preston (Tyendinaga Township CAO)	Enbridge representative noted that they were not aware that speaking sessions were held over lunch. Enbridge representative noted that they were planning on sitting at the IESO over lunch and asked if the Mayor would be interested in attending the session over lunch. They noted that if this does not work for them, a lunch meeting can be scheduled early next month.	January 23, 2023	Township of Tyendinaga noted that they may attend the IESO lunch and if not they would like to schedule a lunch for early next month.
31.33	January 23, 2023	Township of Tyendinaga Contact: Carla Preston (Tyendinaga Township CAO)	Enbridge representative noted that they hope the Township of Tyendinaga can attend, they can still schedule a lunch meeting in a few weeks and to advise if they will be attending today so seats can be saved at their table.	January 23, 2023	Enbridge representative noted that if they are not available for lunch that they will schedule a meeting soon and that it was nice to meet the Mayor and CAO the previous night.
31.34	January 23, 2023	Township of Tyendinaga Contact: Carla Preston (Tyendinaga Township CAO)	Township of Tyendinaga apologized for the delayed response and noted that they were late to the session. They noted that it was great to meet the Enbridge representative in-person.	January 23, 2023	Enbridge representative noted that they attended the Enbridge session re: Energy Transition and asked if Township of Tyendinaga wanted to meet for breakfast the next day (January 24, 2023).
31.35	January 25, 2023	Township of Tyendinaga Contact: Carla Preston (Tyendinaga Township CAO)	Dillon representative provided a Project update and stated that the background review did not identify any active or applicable tree or woodland protection by-laws for the Township and requested confirmation.	January 27, 2023	Township of Tyendinaga provided a link to the tree policy and noted that they do not anticipate the Project will be impacted by it. Township of Tyendinaga requested to be notified of trees that are removed for their records and asked if the preliminary preferred route had changed.
31.36	January 30, 2023	Township of Tyendinaga Contact: Carla Preston (Tyendinaga Township CAO)	Dillon representative thanked the Township of Tyendinaga for the information and noted that they will advise Enbridge to notify them if tree removals are required within the Township. Dillon Consulting stated that no alternative routes had been identified and Enbridge is proceeding with the preliminary preferred route.	N/A	N/A
31.37	January 27, 2023	Township of Tyendinaga Contact: Carla Preston (Tyendinaga Township CAO)	Township of Tyendinaga reached out to Enbridge representative to see if they were interested in arranging a date to meet up.	February 1, 2023	Enbridge representative provided dates at the end of February that work with their schedule and suggested Township of Tyendinaga propose new dates if they do not work with their schedule.
31.38	February 1, 2023	Township of Tyendinaga Contact: Carla Preston (Tyendinaga Township CAO)	Township of Tyendinaga proposed March 7 or 8, 2023 for the meeting.	February 1, 2023	Enbridge representative noted they are unavailable for the proposed dates and proposed March 14, 2023 for the meeting.

Line Item	Date of Consultation	Name of Agency and/or Contact	Description of Consultation Activity	Date of Response	Response and Issue Resolution (if applicable)
31.39	February 2, 2023	Township of Tyendinaga <i>Contact: Carla Preston (Tyendinaga Township CAO)</i>	Township of Tyendinaga agreed to the proposed meeting date.	February 2, 2023	Enbridge representative stated that they are looking forward to the meeting and wished them a good rest of their week.
31.40	March 10, 2023	Township of Tyendinaga <i>Contact: Carla Preston (Tyendinaga Township CAO)</i>	The meeting invite for March 14, 2023 was cancelled due to March Break. Next meeting planned at OGRA conference.	N/A	N/A
32.1	May 2, 2022	Township of Tyendinaga – Planning and Development <i>Contact: Yvonne Murphy</i>	Dillon representative sent Project letter and Notice of Commencement via email.	N/A	N/A
33.1	May 2, 2022	Township of Tyendinaga – Fire Department <i>Contact: James Oliver</i>	Dillon representative sent Project letter and Notice of Commencement via email.	N/A	N/A
34.1	May 2, 2022	Hastings County – Chief Administrative Officer (CAO) <i>Contact: Jim Pine</i>	Dillon representative sent Project letter and Notice of Commencement via email.	N/A	N/A
35.1	May 2, 2022	Hastings County – Planning and Land Development <i>Contact: Justin Harrow</i>	Dillon representative sent Project letter and Notice of Commencement via email.	N/A	N/A
35.2	August 12, 2022	Hastings County – Planning and Land Development <i>Contact: Justin Harrow</i>	Enbridge Gas representative sent the link to the Environmental Report and requested all feedback be provided by September 30, 2022.	N/A	N/A
36.1	May 3, 2022	Hastings County – Facilities and Capital Infrastructure Management <i>Contact: Jim Duffin</i>	Hastings County Director of Facilities emailed the Project inbox acknowledging receipt of the Notice of Commencement and stated that the County has no concerns with the proposed route. The representative noted that open cuts across County Roads will not be permitted.	May 4, 2022	Dillon representative thanked Hastings County representative for their comments on behalf of the County and acknowledged the requirement for crossing County Roads.
36.2	January 23, 2023	Hastings County – Facilities and Capital Infrastructure Management <i>Contact: Jim Duffin</i>	Dillon representative provided a project updated and stated that the background review did not identify any active or applicable tree or woodlot protection by-laws for Hastings County and requested confirmation.	January 24, 2023	Hastings County Director of Facilities stated that the County does not have any tree or woodlot protection by-laws.
36.3	January 24, 2023	Hastings County – Facilities and Capital Infrastructure Management <i>Contact: Jim Duffin</i>	Dillon representative thanked the Hastings County Director of Facilities for the information.	N/A	N/A
37.1	May 2, 2022	Mohawk Fire Department <i>Contact: Scott Maracle</i>	Dillon representative sent Project letter and Notice of Commencement via email.	N/A	N/A

Interest Group Correspondence

Line Item	Date of Consultation	Name of Group and/or Contact	Description of Consultation Activity	Date of Response	Response and Issue Resolution (if applicable)
38.1	May 2, 2022	Quinte Mohawk School <i>Contact: Jennifer Maracle-Westgate</i>	Dillon representative sent Notice of Commencement via email.	N/A	N/A
39.1	May 2, 2022	Hastings and Prince Edward County School Board <i>Contacts: Katherine MacIver (Director) and Tyendinaga Public School</i>	Dillon representative sent Notice of Commencement via email.	N/A	N/A
40.1	May 2, 2022	First Nations Technical Institute <i>Contact: Suzanne Brant</i>	Dillon representative sent Notice of Commencement via email.	N/A	N/A
41.1	May 2, 2022	Kanhiote Library <i>Contact: Brandy Brant</i>	Dillon representative sent Notice of Commencement via email.	N/A	N/A
42.1	May 2, 2022	Mohawk Bus Lines <i>Contact: Mike Hill</i>	Dillon representative sent Notice of Commencement via email.	N/A	N/A
43.1	May 2, 2022	Ontario Federation of Agriculture <i>Contact: Ian Nokes</i>	Dillon representative sent Notice of Commencement via email.	N/A	N/A

Public Correspondence

Line Item	Date of Consultation	Name of Contact	Description of Consultation Activity	Date of Response	Response and Issue Resolution (if applicable)
44.1	May 19, 2022	██████████ Local Resident - Township of Tyendinaga	Resident in Project area called Dillon representative to inquire if people he had seen surveying near his property were associated with Enbridge Gas and the proposed Project. Dillon representative responded that it was unlikely associated with Enbridge Gas, since the Resident's property is outside the planned pipeline construction area. Dillon representative suggested that the Resident check with the Township to determine if it was related to Township work and that they would also look into it internally with Enbridge Gas.	May 19, 2022	Enbridge Gas representative called and left a voicemail for the Resident to discuss their concerns.
44.2	May 20, 2022	██████████ Local Resident - Township of Tyendinaga	Dillon representative followed up with an email to the Resident, thanking them for their call on May 19 and letting them know that they had passed their concerns along to the Enbridge Gas environmental advisor for the Project. Dillon representative noted that the Enbridge Gas representative had told them they had called the Resident and left a voicemail. Dillon representative asked if the Resident had been able to speak to someone at the Township and noted that Enbridge Gas typically doesn't look into these things on their end until the municipality has been contacted first.	May 20, 2022	Enbridge Gas representative responded to Dillon representative's email with an update noting that they had ended up speaking to the Resident on May 19 and were on their way to determining if Enbridge Gas was involved in any work near the Resident's property.
44.3	May 20, 2022	██████████ Local Resident - Township of Tyendinaga	Resident responded stating that they had been able to determine that it was not Enbridge Gas working near their property.	N/A	N/A
45.1	May 20, 2022	██████████ Local Resident & Band Member - Tyendinaga Mohawk Territory	Resident submitted a comment form on the Virtual Information Session website, identifying themselves as a band member. Resident noted that they own property near the pipeline route and that Enbridge Gas needs to expand the pipeline across the river to deliver services to the countless businesses and residents along Highway 2. Resident noted that they are supportive of the Project.	N/A	<i>Note: Resident did not provide contact information for follow-up.</i>
46.1	May 22, 2022	██████████ Member of the Public (outside Study Area)	The individual submitted a comment form on the Virtual Information Session website stating that they do not live near the Project route but that they would like to see natural gas infrastructure expanded to their area. They noted they were supportive of the Project and consider access to natural gas a human rights issue.	June 9, 2022	Dillon representative followed up via email to acknowledge the individual's comments and thank them for participating in the Virtual Information Session. Dillon representative noted that the individual can stay up-to-date on the Project via the Enbridge Gas Project website and provided a link.
47.1	May 29, 2022	██████████████████████ Local Resident & Band Member - Tyendinaga Mohawk Territory	Resident submitted a comment form on the Virtual Information Session website, identifying themselves as a Treaty 3 1/2 Mohawk. Resident stated they have no opinion of the Project at this time and noted that the Virtual Information Session did not provide sufficient information on the Project and the OEB and Environmental Assessment process.	June 9, 2022	Dillon representative followed up via email to acknowledge the Resident's comments and thank them for participating in the Virtual Information Session. Dillon representative inquired whether there was any further information they could provide in regards to the Project and OEB/Environmental Assessment Process. Dillon representative noted that the Resident can stay up-to-date on the Project via the Enbridge Gas Project website and provided a link.
48.1	June 1, 2022	██████████ Local Resident - Tyendinaga Mohawk Territory	Dillon representative followed up with Resident who had attended the in-person Open House on May 30 to provide a PDF copy of the storyboard panels that were on display.	N/A	N/A

Line Item	Date of Consultation	Name of Contact	Description of Consultation Activity	Date of Response	Response and Issue Resolution (if applicable)
49.1	June 21, 2022	██████████ Local Resident - Tyendinaga Mohawk Territory	Dillon representative followed up with Resident who had attended the in-person Open House on May 30, thanking them for their input on the Project and provided a response to a question they had posed about the applicability of Enbridge Gas' energy efficiency rebates on the Tyendinaga Mohawk Territory.	N/A	N/A
50.1	June 21, 2022	██████████ Local Resident - Tyendinaga Mohawk Territory	Dillon representative followed up with Resident who had attended the in-person Open House on May 30, thanking them for their participation and provided responses to questions they had posed about their eligibility for gas service at their residence and the Enbridge Gas rates.	N/A	N/A

Township of Tyendinaga and Mohawks of the Bay of Quinte Community Expansion Project

Project Overview

May 2, 2022



The information contained in these documents is confidential and only for the use of intended recipient and may not be used, published or redistributed without the consent of Enbridge Gas Inc. This document provides general information only and may be subject to change at any time without notice.

Natural Gas Expansion to the Township of Tyendinaga and Mohawks of the Bay of Quinte



Project Scope

~ 17 km of new natural gas pipeline and distribution station

- ~ 14.5km of 2PE pipe (550kPa)
 - ~ 1.13km of this within Township of Tyendinaga
- ~ 2.8km of 4PE pipe (550kPa)
- Station rebuild
- Forecasted customers
 - 124 residential customers
 - 2 commercial / institutional
- Funding allocated: \$8,080,907

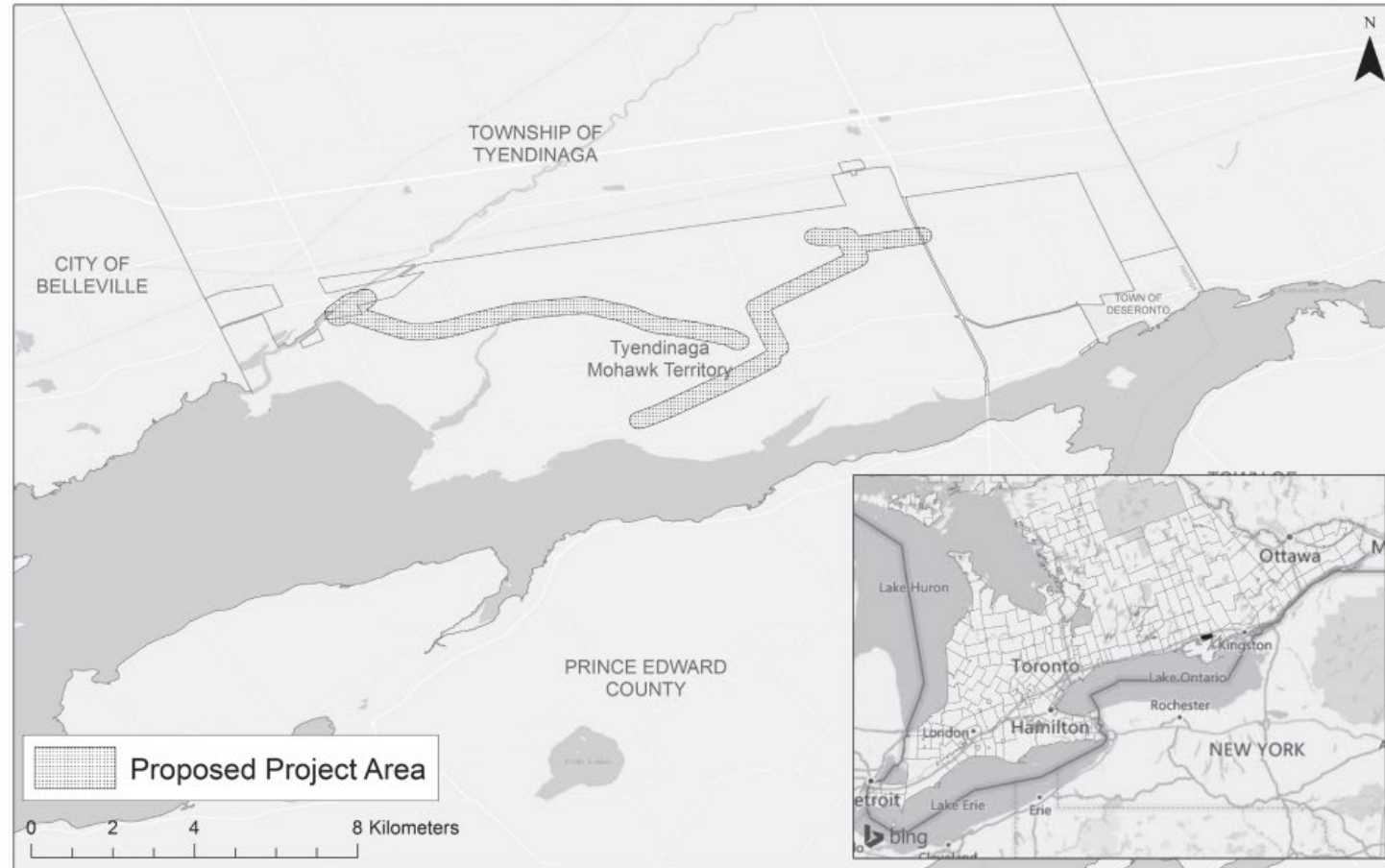

Preliminary Preferred Route

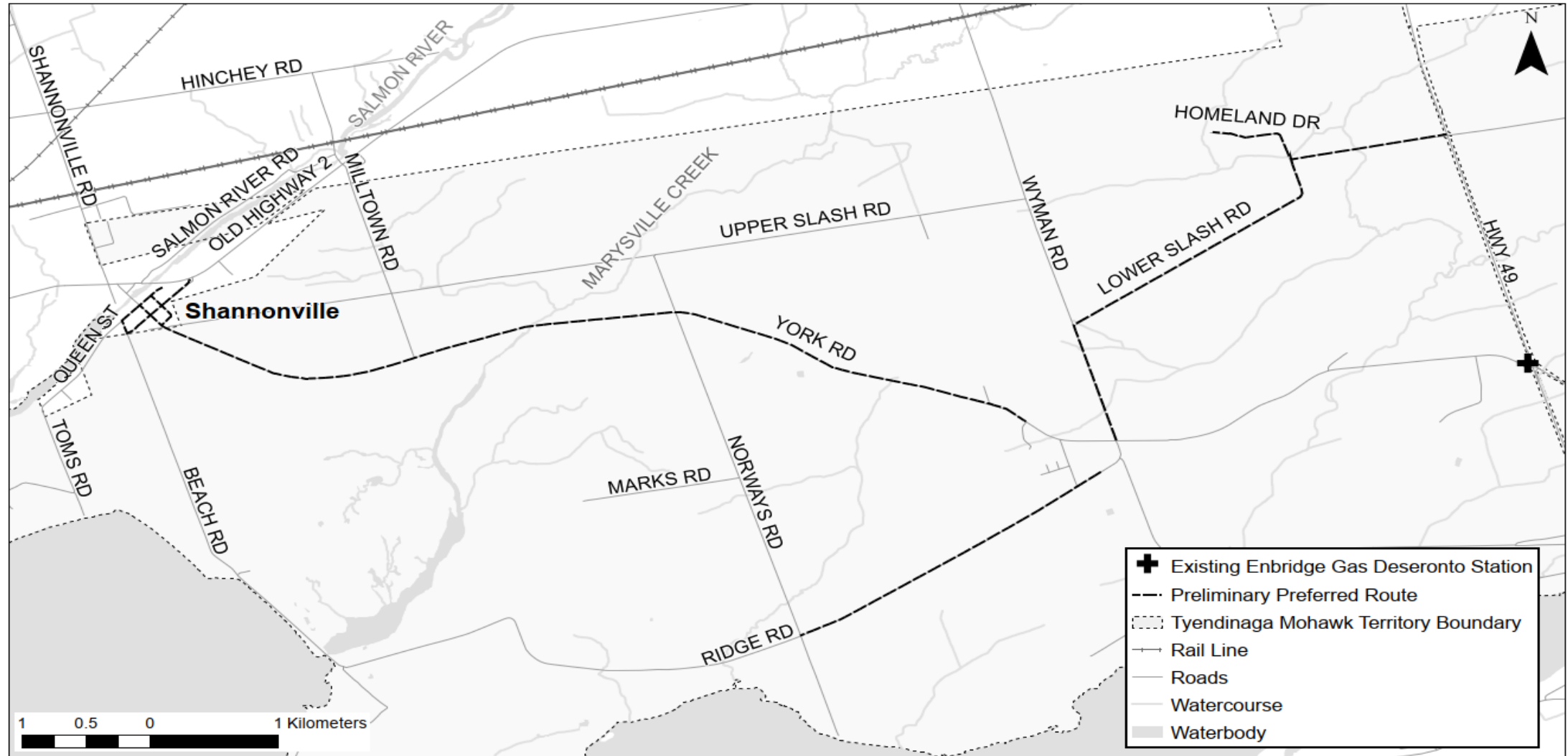



Natural Gas Expansion to the Township of Tyendinaga and Mohawks of the Bay of Quinte

Construction Information

Construction Methods

- Horizontal Directional Drill (HDD)
- Plough

Restoration

- Completed by contractor during construction
- Noise, dust and other disruptions will be mitigated to the extent possible

Natural Gas Expansion to the Township of Tyendinaga and Mohawks of the Bay of Quinte

Regulatory Framework

- The project is being planned in accordance with mandated Ontario Energy Board (OEB) regulations
- In order for the OEB to approve the project for construction, an environmental and cumulative effects assessment is required, and a formal Environmental Report (ER) must be prepared
- Depending on the complexity for the project, OEB may order a written or oral hearing as a part of their evaluation process
- Enbridge hopes to work with the community to file a “Leave to Construct” (LTC) application with the OEB September-October 2022



Ontario Energy Board

ENVIRONMENTAL GUIDELINES FOR THE
LOCATION, CONSTRUCTION AND OPERATION
OF HYDROCARBON PIPELINES
AND FACILITIES IN ONTARIO

7th Edition
2016

Natural Gas Expansion to the Township of Tyendinaga and Mohawks of the Bay of Quinte

Regulatory Framework

- An environmental and cumulative effects assessment is completed to select the most preferred route that meets technical requirements while minimizing potential environmental and/or socio-economic effects
- Physical, natural and socio-economic features are identified in the assessment, and mitigation measures to minimize adverse effects are recommended
- The assessment typically includes comprehensive Indigenous consultation and stakeholder engagement that often includes agencies, municipalities and the public
- Other permits required prior to construction will also be identified



Ontario Energy Board

**ENVIRONMENTAL GUIDELINES FOR THE
LOCATION, CONSTRUCTION AND OPERATION
OF HYDROCARBON PIPELINES
AND FACILITIES IN ONTARIO**

7th Edition
2016

Natural Gas Expansion to the Township of Tyendinaga and Mohawks of the Bay of Quinte



Notice of Commencement (NOC)

- **Notice of Commencement: May 2, 2022**
- A Virtual Open House will be held for two weeks. May 16 – May 29. Information will be posted to a dedicated project email address
- NOC will be published in the Belleville Intelligencer (Postmedia) the weeks of May 2 and May 9.
- As part of the consultation and engagement process, a questionnaire will be available as part of the Virtual Open House, and residents and interested groups will have the opportunity to submit comments and/or questions about the proposed Project. In addition, a copy of the Virtual Open House story boards will be available on the Enbridge Gas project website.

PROPOSED MOHAWKS OF THE BAY OF QUINTE (TYENDINAGA FIRST NATION) AND SHANNONVILLE COMMUNITY SYSTEM EXPANSION PROJECT
NOTICE OF STUDY COMMENCEMENT AND VIRTUAL INFORMATION SESSION
ENBRIDGE GAS INC.

The Study
 Enbridge Gas Inc. (Enbridge Gas) has retained Dillon Consulting Limited to undertake an environmental study for the proposed Mohawks of the Bay of Quinte (MBQ) and Shannonville Community System Expansion Project located within the Tyendinaga Mohawk Territory and Shannonville, Ontario.

Enbridge Gas has identified a preliminary preferred route that will tie-in to an existing 4-inch polyethylene pipeline near the intersection of Wyman Road and York Road in the Tyendinaga Mohawk Territory. The preliminary preferred route has been developed for purposes of an assessment of potential environmental and socio-economic impacts and does not represent the final project scope/design that will provide access to natural gas to end-use customers.

The project is planned to be installed mainly within the existing municipal right-of-way with additional temporary working space potentially required for lay-down, storage and excess soils management. In addition, a station rebuild is required to accommodate additional customers onto the distribution system and will be constructed at the intersection of York Road and Highway 49, in the northwest corner (see map).

Once the study is complete, Enbridge Gas will apply to the Ontario Energy Board (OEB) for approval to construct the project. If approved, construction may begin in spring 2023.

The Process
 The study is being conducted in accordance with the OEB's *Environmental Guidelines for the Location, Construction, and Operation of Hydrocarbon Pipelines and Facilities in Ontario*. The study will review the need and justification for the project, describe the natural and socio-economic environment, evaluate the project from a social and environmental perspective, outline safety measures, and describe appropriate measures for impact mitigation and monitoring.

Invitation to the Community
 Stakeholder and Indigenous consultation is a key component of this study. Members of the general public, landowners, government agencies, current customers, Indigenous communities, and other interested parties are invited to participate in the study. We are hosting a Virtual Information Session to provide you with an opportunity to review the project and provide input.

Virtual Information Session Website: www.MBQvirtualinfosession.ca
Active Dates: Monday, May 16, 2022 to Sunday, May 29, 2022

Your input will be used to confirm the preferred route and create mitigation plans to be implemented during construction. If you are interested in participating, or would like to provide comments, please visit the Virtual Information Session website or contact the project representative using the provided project contact information. The last day to submit comments for consideration in the environmental study is **June 15, 2022**.

Enbridge Gas Project Website: www.enbridgegas.com/MBQCommunityEA

Tristan Lefler
 Environmental Assessment
 Project Manager
 Dillon Consulting Limited
 Suite 200 – 51 Breithaupt St.
 Kitchener, ON N2H 5G5

Alissa Lee
 Environmental Assessment &
 Consultation Lead
 Dillon Consulting Limited
 Suite 101 - 177 Colonnade Rd.
 South, Ottawa, ON K2E 7J4

Project Contact Info:
MBQcommunityEA@dillon.ca
 613-745-2213 ext. 3024

Natural Gas Expansion to the Township of Tyendinaga and Mohawks of the Bay of Quinte



Consultation and Engagement

Ontario Energy Board Leave to Construct (LTC) Application

Ongoing Consultation and Engagement

- The project team is consulting with the Mohawks of the Bay of Quinte on an ongoing basis including participating in the archaeology field studies.

Archaeological Assessments

- Stage 1 AA s ongoing. Stage 2 Archeological field work is scheduled to begin Q3 2022. consultant is Dillon. The majority of the Archaeology will be completed in August/September.
- Enbridge will continue to provide regular updates and continued engagement with MBQ and the Township of Tyendinaga.

Natural Gas Expansion to the Township of Tyendinaga and Mohawks of the Bay of Quinte



Anticipated Mitigation and Protective Measures

Feature	Mitigation and Protective Measures
Socio-economic	<ul style="list-style-type: none"> • Implement a water well monitoring program for private water wells • Develop a Traffic Control Plan • Construction to be completed during regular business hours unless exemptions through municipal permits are obtained • Control dust by tarping excess soils and applying wetting techniques, when required
Terrestrial	<ul style="list-style-type: none"> • Vegetation Removal/Pruning outside of migratory bird window • Nest sweeps prior to tree clearing • Restore and seed areas to establish habitat and reduce erosion
Pipeline Design and Construction	<ul style="list-style-type: none"> • Several steps may be taken to ensure safe, reliable operation of the natural gas network: • Design, construction and testing of pipelines to meet or exceed requirements set by industry standards and regulatory authorities • Continuous monitoring of the entire natural gas network • Perform regular leak surveys to detect and repair leaks
Watercourse and Wetland Crossing	<ul style="list-style-type: none"> • Horizontal Directional Drilling (HDD) will be used to cross under watercourses and wetlands • Environmental inspection during construction in environmentally sensitive areas • Installation of erosion and sediment control measures to prevent erosion and sedimentation into wetlands/watercourses
Species at Risk	<ul style="list-style-type: none"> • Complete construction outside of SAR active periods, if possible • Erect exclusion fencing in proximity to potential SAR habitat • If SAR are found along the preferred pipeline route during Project planning, consultation with the MECP will be initiated regarding the potential need for a permit under the ESA and/or development of species-specific mitigation

Natural Gas Expansion to the Township of Tyendinaga and Mohawks of the Bay of Quinte



Test Digs

- Test digs may be required.
- Required permits will be obtained. (Road Occupancy Permits)
- All test digs are proposed on the shoulder of the road (not in road pavement).
- These test digs will help identify ground conditions, and we may also collect soil samples. This information will help solidify our project design and pipeline running line.
- The test digs are approximately 1m x 1m and 1.2 m deep
- The scope of work will take approximately a few weeks along the proposed project route.



Natural Gas Expansion to the Township of Tyendinaga and Mohawks of the Bay of Quinte



Additional Field Work

- Ongoing field work throughout the year will involve surveys conducted by JD Barnes.
- Residents may see JD Barnes in the area completing this work.
 - Non-invasive
 - Includes mapping out above ground features, property lines, surveying, verifying subsurface utilities
- Dillon will also be completing work related to the Environmental Report required for the Leave to Construct application.



Natural Gas Expansion to the Township of Tyendinaga and Mohawks of the Bay of Quinte



Proposed Project Schedule

Proposed Timeline*

2021-2022

Planning and Design

- Pre-work (TOPO, SUE, ground conditions)
- Environmental Investigations (SAR, ARCH, Cultural Heritage, etc.)
- Selection of Running Lines
- Understanding Community Plans

Q1-Q2 2023

Regulatory Approvals

Q2 2023

Construction Commences

*Pending regulatory approvals and permits

Thank you!

Q&A

ENBRIDGE GAS INC.

Answer to Interrogatory from
Environmental Defence ("ED")

INTERROGATORY

Reference:

Exhibit B, Tab 1, Schedule 1, Pages 2-7

Question(s):

- (a) Has Enbridge Gas conducted any other market research or surveys that would be relevant to this project other than the surveys described on pages 2-7? If yes, please provide all details, including the content of the other research/survey questions and the full detailed results therefrom.
- (b) Has Enbridge held any information sessions in or around the project area? If yes, please provide all of the materials used in those information sessions.
- (c) Has Enbridge mailed materials to individuals in the project area in relation to community expansion or potential individual gas conversions? If yes, please provide full copies.

Response

- (a) and (b)
Please see the responses to Exhibit I.ED.2, Exhibit I.STAFF.1 part (d), and EB-2022-0249 Exhibit I.ED.28, part (b).
- (c) Enbridge Gas mailed the Notice of Hearing together with a copy of the current Leave to Construct application and all supporting evidence to all parties identified in the OEB's Letter of Direction dated February 9, 2023, including:
 - a. all property owners and encumbrancers with lands or interest in lands identified in the search of title
 - b. the Chief Administrative Officer of the Township of Tyendinaga
 - c. the Chief of the Tyendinaga Mohawk Council

- d. all Indigenous communities that have been consulted or with lands or interest in the lands directly affected by the proposed pipeline and related facilities, including all Indigenous communities identified in any delegation letter received from the Ministry of Energy
- e. the Métis Nations of Ontario, Suite 1100 – 66 Slater Street, Ottawa, ON K1P 5H1
- f. all affected utilities and railway companies
- g. members of the Ontario Pipeline Coordinating Committee
- h. Quinte Region Conservation Authority
- i. Ministry of Citizenship and Multiculturalism
- j. Fisheries and Oceans Canada

ENBRIDGE GAS INC.

Answer to Interrogatory from
Environmental Defence (“ED”)

INTERROGATORY

Reference:

Exhibit A, Tab 2, Schedule 1

Question(s):

- (a) Please provide the total number of potential customers that could be connected to the new gas pipelines (i.e. the number of dwellings and businesses), and a breakdown by (a) residential total, (b) residential seasonal, (c) residential permanent, (d) commercial, and (e) other.
- (b) Please provide the attachment forecast as a percent of customers along the new pipe.
- (c) Please provide a list of all addresses that could be served by the proposed pipeline.

Response

- (a) Please see Table 1 below.

Table 1: Breakdown of Potential Customers

Customer Category	Total Potential
Residential Total	255
Residential Seasonal	0
Residential Permanent	255
Commercial Total	17
Other Total (Industrial)	1

- (b) Please see Table 2 below.

The overall percentage of attachments assumed across all customer types is approximately 65% of the total potential identified in Table 1 above. This value is

established using past attachment experience for commercial/industrial customers, customer conversations, and expressions of interest, if available, as well as results from the Mohawks of the Bay of Quinte & Township of Tyendinaga Natural Gas Questionnaire.¹

Table 2 below provides the 10-year attachment forecast (Exhibit B, Tab 1, Schedule 1, Table 2: Forecasted Customer Attachments for the Project) as a percent of the total potential customers in the Project area.

¹ Exhibit B, Tab 1, Schedule 1, Attachment 4

- (c) As final engineering design and individual customer service connections remain uncertain at this time, the customer-specific information sought by ED is not readily available. However, the Company has made available on its website, a tool to search for address ranges within communities across Ontario where the Company is constructing projects that are subject to an expansion surcharge (e.g., SES):

<https://www.enbridgegas.com/residential/new-customers/surcharge>

Additionally, the Company has set out a list of directly and indirectly affected landowners (including address) at Exhibit G, Tab 1, Schedule 1, Attachment 3.

ENBRIDGE GAS INC.

Answer to Interrogatory from
Environmental Defence (“ED”)

INTERROGATORY

Reference:

Exhibit B, Tab 1, Schedule 1 & Attachment 3

Question(s):

- (a) Please provide a copy of all materials available at the Fall Fair referred to on Page 2, Schedule 1.
- (b) Please provide a copy of all materials distributed door-to-door as referred to on Page 2, Schedule 1.
- (c) Please provide the full script(s), talking points, and training materials provided to the individuals who conducted any door-to-door surveys.
- (d) Please provide any letters distributed to residents regarding the project.
- (e) If there were any, please provide the full text and full details of any online and CATI surveys. Please provide the full script(s), talking points, and training materials provided to the individuals who assisted with any CATI surveys.
- (f) Please provide the fully granular survey responses. Please include all details, including what kind of survey was completed (door-to-door, online, or CATI), date of the survey, answers to each question, and whether the survey was 100% completed. For readability, we would appreciate receiving a copy as an excel spreadsheet.
- (g) If it is not clear from (f), please provide a breakdown of the customers likely to switch to gas based on their current heating type.
- (h) If it is not clear from (f), please indicate the number of respondents with air conditioning. If that question was not asked, please provide an average number based on Ontario’s housing stock or Enbridge’s equipment surveys (Enbridge may need to provide a response).

Response

(a) and (b)

Please see the response to EB-2022-0249, Exhibit I.ED.28 parts (b) and (c), for the generic marketing materials used at the Fall Fair and for door-to-door distribution.

(c) Enbridge Gas subject matter experts in customer attachment conducted door-to-door surveys of potential residential customers. The Customer Attachment team communicated the purpose of their survey, which was to gauge community interest in natural gas, and informed residents that that information provided may be used to support any Project-related leave to construct Application with the OEB. The team asked questions about customers general awareness of the Project and ensured that each customer was aware of the system expansion surcharge (“SES”). Customers were provided energy system cost comparisons and explanations as to how the SES is applied based on consumption. The team also asked customers of their general interest in natural gas, their current heating source/energy, and if they had any questions pertaining to the proposed Project itself. No training materials or script(s) were provided to the Enbridge Gas Customer Attachment team that conducted the door-to-door surveys.

(d) Please see the response to Exhibit I.ED.3, part c).

(e) No online or CATI surveys were initiated for the Project.

(f) and (g)

Please see Exhibit B, Tab 1, Schedule 1, Attachment 4 for Questionnaire results. The responses to the Questionnaire are provided in live Excel format as Attachment 1 to this response. A tab within provides a list of the questions and the response selections available. Specific dates were not requested or indicated on individual Questionnaires with survey responses ranging in date from September 11, 2022 (Fall fair / door-to-door) to December 20, 2022. For details on how the Questionnaire was distributed, please see the description set out at Exhibit B, Tab 1, schedule 1, p. 2.

(h) Enbridge Gas did not collect information related to air conditioning. Among existing residential customers living in single-family homes across Enbridge Gas’ entire service territory, the 2022 Residential Single Family Natural Gas End Use study conducted by Enbridge Gas found that 89% have air conditioning, of which 90% is a central air conditioning system.¹ However, there is considerable variation in air conditioning according to customer-specific location across the Company’s franchise

¹ EB-2022-0200, Exhibit I.1.10-GEC-7, Attachment 1

area. The communities affected by the proposed Project are located within the Enbridge Gas Eastern Region where 90% of existing customers have air conditioning.

Question/Response	
1. Are you in support of bringing natural gas to your community?	
	Yes
	No
2. How likely would you be to convert to natural gas knowing that depending on your situation, the cost to switch to Natural Gas could range from \$400 to \$12,500?	
	Extremely likely
	Very Likely
	Likely
	Not very likely
	Not at all likely
3. Assuming Natural Gas service is made available to you in 2023, when would you likely switch your home heating to natural gas?	
	Within first 12 months
	1 to 2 years of the availability
	2-3 years of the availability
	After 3 years of the availability
4. How many square feet is your home (not including any unfinished basement)?	
	Less than 100 square ft
	1000-1500 square feet
	1501-2000 square ft
	Over 2000 square ft
	Don't know
5. How do you currently heat your home?	
	Electric Baseboard
	Electric heat pump
	Air source heat pump
	Propane boiler
	Wood forced air
	Wood stove/fireplace
	Electric forced air
	Ground source heat pump
	Propane forced air
	Oil forced air
	Oil boiler
	No heating system
	Other
	Furnace Oil
	Propane Fire Standing Stove
6. How likely would you be ok to seek out more information about installing a heat pump heating and cooling system for your home?	
	Extremely likely
	Very likely
	Likely
	Not very likely
	Not at all likely
	Other (Question Mark)

Survey #	Question 1	Question 2	Question 3	Question 4	Question 5	Question 5 Alternate 1	Question 5 Alternate 2	Question 6	Was survey 100% Completed
1	Yes	Extremely likely	Within first 12 months	Over 2000 square ft	Oil forced air			Extremely likely	Yes
2	Yes	Very Likely	Within first 12 months	1000-1500 square feet	Oil forced air			Not at all likely	Yes
3	Yes	Likely	After 3 years of the availa	1501-2000 square ft	Oil forced air		Wood stove/fireplace	Likely	Yes
4	Yes	Extremely likely	Within first 12 months	1000-1500 square feet	Wood stove/fireplace			Likely	Yes
5	Yes	Very Likely	1 to 2 years of the availat	1501-2000 square ft	Oil forced air			Likely	Yes
6	Yes	Extremely likely	Within first 12 months	1000-1500 square feet	Oil forced air			Not at all likely	Yes
7		Very Likely	After 3 years of the availa	1000-1500 square feet	Oil forced air			Not at all likely	No
8	Yes	Not very likely	After 3 years of the availa	1501-2000 square ft	Propane forced air			Not at all likely	Yes
9	Yes	Likely	Within first 12 months	1000-1500 square feet	Oil forced air		Propane forced air	Likely	Yes
10	Yes	Extremely likely	Within first 12 months	1000-1500 square feet	Propane boiler			Extremely likely	Yes
11	Yes	Very Likely	Within first 12 months	Over 2000 square ft	Oil forced air			Likely	Yes
12	Yes	Likely	Within first 12 months	Over 2000 square ft	Furnace Oil			Likely	Yes
13	Yes	Extremely likely	Within first 12 months	1000-1500 square feet	Wood stove/fireplace	Propane forced air	Electric Baseboard	Not at all likely	Yes
14	Yes	Likely	Within first 12 months	1000-1500 square feet	Propane forced air			Very likely	Yes
15	Yes	Very Likely	Within first 12 months	1000-1500 square feet	Propane forced air			Very likely	Yes
16	Yes	Extremely likely	Within first 12 months	Over 2000 square ft	Propane forced air			Extremely likely	Yes
17	Yes	Very Likely	Within first 12 months	1000-1500 square feet	Propane forced air			Not at all likely	Yes
18	Yes	Extremely likely	Within first 12 months	1501-2000 square ft	Propane boiler	Propane forced air		Extremely likely	Yes
19	Yes	Extremely likely	Within first 12 months	Over 2000 square ft	Propane boiler	Propane forced air		Extremely likely	Yes
20	Yes	Extremely likely	Within first 12 months	Over 2000 square ft	Propane forced air			Likely	Yes
21	Yes	Extremely likely	Within first 12 months	1000-1500 square feet	Propane forced air			Not very likely	Yes
22	Yes	Extremely likely	Within first 12 months	1000-1500 square feet	Oil forced air			Likely	Yes
23	Yes	Extremely likely	Within first 12 months	1501-2000 square ft	Propane forced air			Not very likely	Yes
24	Yes	Very Likely	Within first 12 months	1000-1500 square feet	Propane forced air			Very likely	Yes
25	Yes	Likely	Within first 12 months	Over 2000 square ft	Propane forced air			Likely	Yes
26	Yes	Very Likely	Within first 12 months	1501-2000 square ft	Wood stove/fireplace			Very likely	Yes
27	No	Likely	1 to 2 years of the availat	1000-1500 square feet	Electric forced air			Extremely likely	Yes
28	Yes	Extremely likely	Within first 12 months	1000-1500 square feet	Propane forced air			Not at all likely	Yes
29	Yes	Extremely likely	Within first 12 months	1000-1500 square feet	Propane forced air			Extremely likely	Yes
30	Yes	Extremely likely	Within first 12 months	1000-1500 square feet	Propane boiler			Extremely likely	Yes
31	Yes	Very Likely	1 to 2 years of the availat	1501-2000 square ft	Propane forced air			Not very likely	Yes
32	No	Likely	1 to 2 years of the availat	1000-1500 square feet	Propane boiler			Likely	Yes
33	Yes	Very Likely	After 3 years of the availa	Over 2000 square ft	Furnace Oil		Electric Baseboard	Extremely likely	Yes
34	Yes	Extremely likely	Within first 12 months						No
35				1000-1500 square feet	Electric Baseboard	Propane forced air	Propane Fire Standing Stove	Not at all likely	No
36	Yes	Extremely likely	1 to 2 years of the availat	Don't know	Propane boiler			Extremely likely	Yes
37	Yes	Very Likely	Within first 12 months	1000-1500 square feet	Propane forced air			Likely	Yes
38	Yes	Not very likely		Less than 100 square ft	Oil forced air			Not very likely	No
39	Yes	Extremely likely	Within first 12 months	1000-1500 square feet	Propane forced air			Not at all likely	Yes
40	Yes	Very Likely	Within first 12 months	1501-2000 square ft	Oil forced air			Not very likely	Yes
41	Yes	Likely	After 3 years of the availa	Over 2000 square ft	Oil forced air			Not at all likely	Yes
42	Yes	Extremely likely	Within first 12 months	1000-1500 square feet	Oil forced air			Not very likely	Yes
43	Yes	Extremely likely	Within first 12 months	Less than 100 square ft	Propane forced air			Extremely likely	Yes
44	Yes	Very Likely	Within first 12 months	1000-1500 square feet	Propane forced air			Likely	Yes
45	Yes	Extremely likely	Within first 12 months	Over 2000 square ft	Wood stove/fireplace	Propane forced air		Likely	Yes
46	Yes	Very Likely	Within first 12 months	1000-1500 square feet	Propane forced air			Very likely	Yes
47	Yes	Extremely likely	Within first 12 months	1501-2000 square ft	Wood stove/fireplace	Propane forced air		Likely	Yes
48	Yes	Very Likely	Within first 12 months	Over 2000 square ft	Propane forced air			Not very likely	Yes
49	Yes	Very Likely	Within first 12 months	1000-1500 square feet	Oil forced air			Not very likely	Yes
50	Yes	Likely	After 3 years of the availa	1501-2000 square ft	Oil forced air			Likely	Yes
51	Yes	Not very likely	After 3 years of the availa	Over 2000 square ft	Propane forced air			Not at all likely	Yes
52	Yes	Very Likely	Within first 12 months	1501-2000 square ft	Oil forced air			Not very likely	Yes
53	Yes	Very Likely	Within first 12 months	1501-2000 square ft	Propane forced air			Likely	Yes
54	Yes	Very Likely	Within first 12 months	Don't know	Oil forced air			Very likely	Yes
55	Yes	Not at all likely		1000-1500 square feet	Propane Fire Standing Stove			Not at all likely	No
56	Yes	Not very likely	After 3 years of the availa	Over 2000 square ft	Propane forced air			Not at all likely	Yes
57	Yes	Not very likely	After 3 years of the availa	Don't know	Oil forced air			Not very likely	Yes
58	Yes	Likely	1 to 2 years of the availat	1501-2000 square ft	Oil forced air			Extremely likely	Yes
59	Yes	Extremely likely	Within first 12 months	Over 2000 square ft	Propane forced air			Not very likely	Yes
60	Yes	Likely	1 to 2 years of the availat	1000-1500 square feet	Propane forced air			Likely	Yes
61	Yes	Likely	2-3 years of the availabiliit	Don't know	Wood stove/fireplace	Propane forced air	Electric Baseboard	Likely	Yes
62	Yes	Extremely likely	Within first 12 months	Over 2000 square ft	Propane forced air			Likely	Yes
63	Yes	Likely	Within first 12 months	Less than 100 square ft	Oil forced air			Very likely	Yes
64	Yes	Very Likely	After 3 years of the availa	1000-1500 square feet	Propane forced air			Not very likely	Yes
65	Yes	Not very likely	After 3 years of the availa	Don't know	Propane forced air			Not very likely	Yes
66	Yes	Very Likely	Within first 12 months	1501-2000 square ft	Propane forced air	Other		Not at all likely	Yes
67	Yes	Very Likely	1 to 2 years of the availat	1000-1500 square feet	Electric Baseboard			Very likely	Yes
68	Yes	Likely	Within first 12 months	1501-2000 square ft	Propane forced air			Other (Question Mark)	No
69	Yes	Very Likely	Within first 12 months	Less than 100 square ft	Propane forced air			Likely	Yes
70	Yes	Very Likely	Within first 12 months	Less than 100 square ft	Propane forced air			Likely	Yes
71	Yes	Likely	Within first 12 months	1501-2000 square ft	Other			Not at all likely	Yes

ENBRIDGE GAS INC.

Answer to Interrogatory from
Environmental Defence (“ED”)

INTERROGATORY

Reference:

Exhibit B, Tab 1, Schedule 1, Attachment 3

Question(s):

- (a) Please provide all excerpts from all materials provided to residents that provide details on the comparative cost-effectiveness of heating with electric air source heat pumps versus gas.
- (b) Were survey respondents told that they may be eligible for up to \$5,000 rebates for installing air source heat pumps? If yes, please provide the precise text used in the correspondence or surveyor script.
- (c) Were survey respondents told that they may be eligible for up to \$10,000 rebates for installing air source heat pumps if their current heating system was oil? If yes, please provide the precise text used in the correspondence or surveyor script.
- (d) Were survey respondents provided with information on the comparative cost effectiveness of gas that accounts for carbon tax rising to \$170/tCO₂e by 2030?
- (e) Please provide a table showing the Federal Carbon Charge Rates for Marketable Natural Gas from 2019 to 2030, with columns for \$/tCO₂e and cents/m³.

Response

- (a) The Mohawks of the Bay of Quinte & Township of Tyendinaga Natural Gas Questionnaire (“Questionnaire”) indicates that Government incentives are available to reduce purchase costs associated with heat pumps.¹

¹ Exhibit B, Tab 1, Schedule 1, Attachment 3, p. 2, footnote 1

Enbridge Gas did not provide details on the comparative cost-effectiveness of heating with electric air source heat pumps versus gas. Please see the response at EB-2022-0249 Exhibit I.ED.1 part a), for more information.

(b) and (c)

No, the Project-specific survey script did not include any content dealing with the matter of existing or potential government funding (rebates) for air source heat pumps.

(d) No. The Questionnaire included annual estimated costs and savings based on current energy and carbon costs.²

(e) The Federal Carbon Charge rates for Marketable Natural Gas from 2019 to 2030 are shown in Table 1 below.

Table 1: 2019 – 2030 Federal Carbon Charge Rates for Marketable Natural Gas³

Year	\$/tCO₂e	cents/m³
2019	\$20	3.91
2020	\$30	5.87
2021	\$40	7.83
2022	\$50	9.79
2023	\$65	12.39
2024	\$80	15.25
2025	\$95	18.11
2026	\$110	20.97
2027	\$125	23.83
2028	\$140	26.69
2029	\$155	29.54
2030	\$170	32.40

² Exhibit B, Tab 1, Schedule 1, Attachment 3, p. 3

³ For the rates in \$/tCO₂e refer to the Greenhouse Gas Pollution Pricing Act, Schedule 4, and for the rates in cents/m³ refer to the Greenhouse Gas Pollution Pricing Act, Schedule 2, <https://laws-lois.justice.gc.ca/PDF/G-11.55.pdf>.

ENBRIDGE GAS INC.

Answer to Interrogatory from
Environmental Defence (“ED”)

INTERROGATORY

Reference:

Exhibit B, Tab 1, Schedule 1

Question(s):

- (a) Please reproduce the customer attachment forecast broken down by the current customer primary heating system/fuel. Please make and state assumption as necessary (e.g. Enbridge may estimate the fuel type of connecting customers based on the proportions of customers with that fuel type indicating an interest in converting to gas in the surveys). Please provide the underlying calculations. We are most interested in the overall totals after 10 years, but please also provide the annual breakdown if possible.

Response

- (a) Please see the response at EB-2022-0249 Exhibit I.ED.7

ENBRIDGE GAS INC.

Answer to Interrogatory from
Environmental Defence (“ED”)

INTERROGATORY

Reference:

Exhibit E, Tab 1, Schedule 1, Page 1

Preamble:

“The cost estimate set out above differs from the amount estimated in the Company’s original project proposal to the Government of Ontario (2019/2020) for funding under Phase 2 of the NGEP by approximately \$1.5 million (EB-2019-0255).”

Question(s):

- (a) Please provide a table providing a table with a full reconciliation as between the estimated project costs in Table 1 and the amount estimated in the Company’s original project proposal to the Government of Ontario (2019/2020) for funding under Phase 2 of the NGEP (EB-2019-0255).
- (b) Please provide the complete copy of the above-referenced project proposal.
- (c) Please provide the 40-year DCF table underling the project proposal to the Government of Ontario (2019/2020) for funding under Phase 2 of the NGEP (EB-2019-0255).

Response

- (a) and (b)
Please see the response at Exhibit I.STAFF.3
- (c) Please see Attachment 1 to this response.

ENBRIDGE GAS INC.

Answer to Interrogatory from
Environmental Defence (“ED”)

INTERROGATORY

Reference:

Exhibit E, Tab 1, Schedule 1, Page 1

Question(s):

- (a) Please reproduce Table 1 with an added column showing the totals, including both pipeline costs and ancillary costs.
- (b) Please provide Enbridge’s definition of “ancillary costs” as that term is used in Table 1. Please provide a full explanation.
- (c) Please compare the concept of “ancillary costs” with allocated overhead, including a reconciliation of the concepts in a table if there is partial overlap.

Response

- (a) Please see the response to Exhibit I.STAFF.3, for totals including pipeline and ancillary costs set out in Table 1.
- (b) Generally, ancillary costs include all Project costs not directly related to the pipeline facilities that require an order of the OEB granting leave to construct, including but not limited to the construction of facilities for individual customer services and stations (e.g., pressure regulation, measurement, odorization).¹

In the case of the proposed Project, the facilities associated with ancillary costs include:

Station

- materials,
- labour/construction,

¹ EB-2022-0248 Exhibit E, Tab 1, Schedule 1, p. 1, footnote 1

- land agreement,
- fencing,
- painting, and
- permits.

Services

- contractor labour & construction, and
- meter/reg installation.

(c) There is no correlation between ancillary costs and overheads; ancillary costs refer to natural gas asset types whereas Project overheads account for the labour cost associated with full time employees and contingent workers supporting the project.

ENBRIDGE GAS INC.

Answer to Interrogatory from
Environmental Defence (“ED”)

INTERROGATORY

Reference:

Exhibit E, Tab 1, Schedule 1, Page 1

Question(s):

(a) Please provide a table of figures showing, without rounding: the gross capital cost, the gross O&M costs over 40 years, the NPV of the O&M costs over 40 years, the subsidy, the gross revenue over 40 years, and the NPV of the revenue over 40 years

Response

(a) Please see Table 1:

Table 1: Mohawks of the Bay of Quinte

Gross Capital Costs	\$ 10,715,495
Gross O&M Over 40 Years	\$ 1,035,554
NPV of O&M Over 40 Years	\$ 437,606
Subsidy	\$ 8,080,907
Gross Revenue (including SES) Over 40 Years	\$ 7,924,441
NPV of Revenue (including SES) Over 40 Years	\$ 3,410,052

ENBRIDGE GAS INC.

Answer to Interrogatory from
Environmental Defence (“ED”)

INTERROGATORY

Reference:

Exhibit E, Tab 1, Schedule 1, Page 1

Question(s):

(a) Please complete the following table:

Capital Costs Per Customer	
Forecast gas customers (total)	
Total capital costs	
Capital costs per customer	

(b) Please complete the following table:

Capital and Operating Costs Per Customer	
Forecast gas customers (total)	
Total capital costs and gross O&M costs over 40 years	
Capital and O&M costs per customer	

(c) Please complete the following table:

Capital and Operating Costs Per Customer (Excl. Costs Covered by the Subsidy)	
Forecast gas customers (total)	
Total capital costs and gross O&M costs minus the subsidy from existing customers	
Capital and O&M costs per customer (excl. subsidy)	

Response

(a) Please see Table 1 below.

Table 1: Capital Costs Per Customer	
Forecast gas customers (total)	179
Total capital costs (before subsidy)	\$10,715,494
Capital costs per customer	\$59,863

(b) Please see Table 2 below.

Table 2: Capital and Operating Costs Per Customer	
Forecast gas customers (total)	179
Total capital costs and gross O&M costs over 40 years	\$11,751,048
Capital and O&M costs per customer	\$65,648

(c) Please see Table 3 below.

Table 3: Capital and Operating Costs Per Customer (Excl. Costs Covered by the Subsidy)	
Forecast gas customers (total)	179
Total capital costs and gross O&M costs minus the subsidy from existing customers	\$3,670,141
Capital and O&M costs per customer (excl. subsidy)	\$20,504

ENBRIDGE GAS INC.

Answer to Interrogatory from
Environmental Defence (“ED”)

INTERROGATORY

Reference:

Exhibit E, Tab 1, Schedule 1, Page 1

Question(s):

- (a) If there are significant revenue shortfalls or cost overruns in years 1 through 10 that Enbridge is unable to recoup from increasing the system expansion surcharge, does Enbridge undertake not to seek to recoup the amounts from existing Enbridge customers?
- (b) If there are significant revenue shortfalls or cost overruns in years 11 through 40 that Enbridge is unable to recoup from increasing the system expansion surcharge, does Enbridge undertake not to seek to recoup the amounts from existing Enbridge customers?

Response

- (a) and (b)
Please see the response to EB-2022-0249, Exhibit I.ED.12.

ENBRIDGE GAS INC.

Answer to Interrogatory from
Environmental Defence (“ED”)

INTERROGATORY

Reference:

Exhibit E, Tab 1, Schedule 1, Attachment 2

Question(s):

- (a) Please reproduce the DCF table with an illustrative scenario where customer attachments each year are 50% of those forecast. Enbridge does not need to agree this scenario is likely – it is intended to illustrate the cost impacts.
- (b) With respect to the response to (a), please provide (i) the revenue deficiency over the first 10 years (both gross and NPV) and the (ii) the revenue deficiency over the remaining 30 years (both gross and NPV).

Response

a) and b)

Please see the response at EB-2022-0249 Exhibit I.ED.13

ENBRIDGE GAS INC.

Answer to Interrogatory from
Environmental Defence (“ED”)

INTERROGATORY

Reference:

Exhibit E, Tab 1, Schedule 1, Attachment 2

Question(s):

(a) Please complete the following table showing the outcomes in various scenarios in terms of the profitability index, NPV, and gross revenue deficiency. Enbridge does not need to agree these scenarios are likely.

Cost Impact of Different Customer Attachment / Revenue Scenarios					
	Profitability index	NPV	Revenue deficiency (years 1-10)	Revenue deficiency (years 11-40)	Revenue deficiency (years 1-40)
Volumes plateau in year 5 and do not increase					
After year 10, 10 customers exit the system each year (net)					
Volumes are 20% less than forecast each year					

Response

a) Please see the response at EB-2022-0249 Exhibit I.ED.14

ENBRIDGE GAS INC.

Answer to Interrogatory from
Environmental Defence (“ED”)

INTERROGATORY

Reference:

Exhibit E, Tab 1, Schedule 1, Attachment 2

Question(s):

- (a) What is the average all-in cost to connect a new residential customer to the gas system, including the cost of the meter, regulator, the pipe serving that specific customer, and the installation costs?
- (b) Please provide a table showing, for each year, the forecast customer attachments, the estimated average cost to attach a customer (e.g. the meter, the pipe serving that customer only, labour, etc.), the estimated cost that will be covered by rates, and the estimated cost that will be covered by the customers directly.
- (c) Please reproduce the DCF table with a row showing the customer attachment costs (i.e. the meter, the pipe serving that customer only, labour, etc.) for each year broken out from other costs. If those costs are not included, please reproduce the DCF table including those costs.
- (d) What are the average incremental operational costs for Enbridge per average residential customer (e.g. billing, etc). Please provide a breakdown of these costs.
- (e) Are the costs in (c) included in the DCF table?

Response

- a) There are several factors that influence the cost of servicing that can result in significant variability between projects. These factors include, but are not limited to: site specific ground conditions (e.g. presence of rock), land parcel and building configuration, service length, location and depth of the connecting main (for tie in), and customer type (design varies based on connected load).

Project-specific service estimates are prepared for each community expansion project based on measured average service lengths, general sizing for the project and site conditions. These project-specific estimates more accurately reflect the cost of servicing in the proposed project area, which may differ from the Company's regional averages (established across a broader geographic location).

The estimated average all-in service cost for the Project is \$9,883 per customer.

/U

- b) Please see Table 1 below for information regarding forecast customer attachments and estimated costs to attach customers by year. In Enbridge Gas's initial response filed May 2, 2023 the Company misunderstood ED's request. Upon further consideration, Enbridge Gas is not able to provide the estimated cost to attach customers by the amount that would be covered by rates and the amount that would be covered by customers directly. Enbridge Gas is not able to provide those amounts as they are not reasonably attributable to the specific costs to attach a customer (e.g., the meter, the pipe serving that customer only) versus the costs for other components of the Project (e.g. mains, stations) and are attributed to the Project in its entirety.

/U

For example, customers who attach to the natural gas system as part of the Project will be charged an SES which is not attributable to the costs to attach the customer versus the cost for other components of the project. Similarly, NGEF funding is also not attributable in this manner.

Table 1: Service Cost for Residential Customers

Row No.	Description	Year										
		1	2	3	4	5	6	7	8	9	10	Total
1.0	Forecasted attachment	45	40	15	11	8	10	9	10	9	9	166
2.1	Average service cost/customer (\$CAD)	9,883	9,883	9,883	9,883	9,883	9,883	9,883	9,883	9,883	9,883	9,883
2.2	Average excess footage charge/customer (\$CAD)	(557)	(557)	(557)	(557)	(557)	(557)	(557)	(557)	(557)	(557)	(557)
2.3	Average net service cost/customer (\$CAD)	9,326	9,326	9,326	9,326	9,326	9,326	9,326	9,326	9,326	9,326	9,326
2.4	Estimated total net service cost (\$CAD)	419,656	373,028	139,885	102,583	74,606	93,257	83,931	93,257	83,931	83,931	1,548,066

/U

Notes:

Row 1.0 represents the forecasted customer attachments per year.

Row 2.1 represents the average base capital cost per customer to install a service for the project.

Row 2.2 represents the average excess footage charge per customer for the project (paid by customers). For the legacy Union Gas franchise area, this excess footage charge is \$45/m after the first 30 m from the property line. The new connection policy proposed in the rebasing application was not used in this analysis.

Row 2.3 represents the average net base capital cost per customer to install a service for the project.

Row 2.4 represents the total net base capital cost for service installations for the forecasted customer attachments in the given year.

- c) Please see Attachment 1 to this response.
- d) The annual average incremental operational costs per average residential customer is shown in Table 2 below.

Table 2: Annual Average Incremental Operational Costs

Item	O&M Cost
Distribution Operations	81.84
Customer Care	58.76
Employee Benefits	10.93
Average Total per Residential Customer	151.53

- e) Yes.

ENBRIDGE GAS INC.

Answer to Interrogatory from
Environmental Defence (“ED”)

INTERROGATORY

Reference:

Exhibit E, Tab 1, Schedule 1, Attachment 2

Question(s):

- (a) Please provide a table showing the full calculations and assumptions used to generate the revenue forecast from the customer attachment forecast. Please include, among other things, the annual customer attachments, annual customer totals, the use per customer, and the revenue generated per customer.
- (b) If the customer attachment forecast underlying the DCF table differs from the one set out in Exhibit B, Tab 1, Schedule 1, Page 8, please explain and provide a reconciliation table.
- (c) Does Enbridge agree that the number of customer attachments could be impacted by the relative cost-effectiveness of converting to gas versus converting to high-efficiency cold climate air source heat pumps? If not, please explain.
- (d) Does Enbridge agree that the number of customer attachments could be impacted by customer perceptions of the relative cost-effectiveness of converting to gas versus converting to high-efficiency cold climate air source heat pumps? If not, please explain.
- (e) Please provide Enbridge’s best estimate of the relative cost-effectiveness of an average customer in the project area converting to an air-source cold climate heat pump versus gas. Please generate (i) the lifetime difference in total capital costs and operational costs (NPV) based on customer prices over the equipment lifetime and (ii) the difference in average annual operational costs over the equipment lifetime. Please include all material customer-facing costs and benefits, including energy costs, carbon costs, the Greener Homes Grant incentives for heat pumps, and the gains from more efficient summer cooling of an air source heat pump versus a traditional air conditioner. Please provide all calculations and assumptions. Please make assumptions and state caveats as necessary.

Response

- (a) Please see Attachment 1 to this response.
- (b) The customer attachment forecast underlying the DCF table is consistent with the one set out in Exhibit B, Tab 1, Schedule 1, Page 8.
- (c) and d)
No. The attachment forecast is based on the energy interests expressed by actual residents and business-owners within the Project area, which inherently incorporate all factors including financial and non-financial considerations. The Company has no reason to believe that the attachment forecast is inaccurate.
- (e) Please refer to the response at EB-2022-0249 Exhibit I.ED.16, part e).

**Mohawks of the Bay of Quinte Community Expansion
Project Revenue by Year**

	Year												
	1	2	3	4	5	6	7	8	9	10	11-21	22	23-40
Industrial Customer													
Customer Attachments	-	1	-	-	-	-	-	-	-	-	-	-	-
Cumulative Customers	-	1	1	1	1	1	1	1	1	1	1	1	-
Average Use (m3/year)	100,000	100,000	100,000	100,000	100,000	100,000	100,000	100,000	100,000	100,000	100,000	100,000	100,000
Years of Revenue	20												
Annual Revenue:													
Fixed Customer Charge/Customer	918.97	918.97	918.97	918.97	918.97	918.97	918.97	918.97	918.97	918.97	918.97	918.97	918.97
Distribution Margin/Customer	<u>7,707.68</u>	<u>7,707.68</u>	<u>7,707.68</u>	<u>7,707.68</u>	<u>7,707.68</u>	<u>7,707.68</u>	<u>7,707.68</u>	<u>7,707.68</u>	<u>7,707.68</u>	<u>7,707.68</u>	<u>7,707.68</u>	<u>7,707.68</u>	<u>7,707.68</u>
Annual Distribution Revenue/Customer	8,626.66	8,626.66	8,626.66	8,626.66	8,626.66	8,626.66	8,626.66	8,626.66	8,626.66	8,626.66	8,626.66	8,626.66	8,626.66
Distribution Revenue on Current Year Customer Attachments (1/2 year)	-	4,313	-	-	-	-	-	-	-	-	-	-	-
Distribution Revenue on Prior Years Customer Attachments (full year)	-	-	8,627	8,627	8,627	8,627	8,627	8,627	8,627	8,627	8,627	4,313	-
Total Distribution Revenue for the Year - Large Customer #1	-	<u>4,313</u>	<u>8,627</u>	<u>8,627</u>	<u>8,627</u>	<u>8,627</u>	<u>8,627</u>	<u>8,627</u>	<u>8,627</u>	<u>8,627</u>	<u>8,627</u>	<u>4,313</u>	-
SES Revenue Rate (\$/m3)	0.23	0.23	0.23	0.23	0.23	0.23	0.23	0.23	0.23	0.23	0.23	0.23	0.23
SES Revenue on Current Year Customer Attachments (1/2 year)	-	11,500	-	-	-	-	-	-	-	-	-	-	-
SES Revenue on Prior Years Customer Attachments (full year)	-	-	23,000	23,000	23,000	23,000	23,000	23,000	23,000	23,000	23,000	11,500	-
Total SES Revenue for the Year - Large Customer #1	-	<u>11,500</u>	<u>23,000</u>	<u>23,000</u>	<u>23,000</u>	<u>23,000</u>	<u>23,000</u>	<u>23,000</u>	<u>23,000</u>	<u>23,000</u>	<u>23,000</u>	<u>11,500</u>	-
Total Distribution + SES Revenue - Large Customer #1	-	<u>15,813</u>	<u>31,627</u>	<u>31,627</u>	<u>31,627</u>	<u>31,627</u>	<u>31,627</u>	<u>31,627</u>	<u>31,627</u>	<u>31,627</u>	<u>31,627</u>	<u>15,813</u>	-
Specialized Commercial Customer													
Customer Attachments	-	1	-	-	-	-	-	-	-	-	-	-	-
Cumulative Customers	-	1	1	1	1	1	1	1	1	1	1	1	1
Average Use (m3/year)	21,060	21,060	21,060	21,060	21,060	21,060	21,060	21,060	21,060	21,060	21,060	21,060	21,060
Years of Revenue	40												
Annual Revenue:													
Fixed Customer Charge/Customer	275.74	275.74	275.74	275.74	275.74	275.74	275.74	275.74	275.74	275.74	275.74	275.74	275.74
Distribution Margin/Customer	<u>2,000.21</u>	<u>2,000.21</u>	<u>2,000.21</u>	<u>2,000.21</u>	<u>2,000.21</u>	<u>2,000.21</u>	<u>2,000.21</u>	<u>2,000.21</u>	<u>2,000.21</u>	<u>2,000.21</u>	<u>2,000.21</u>	<u>2,000.21</u>	<u>2,000.21</u>
Annual Distribution Revenue/Customer	2,275.95	2,275.95	2,275.95	2,275.95	2,275.95	2,275.95	2,275.95	2,275.95	2,275.95	2,275.95	2,275.95	2,275.95	2,275.95
Distribution Revenue on Current Year Customer Attachments (1/2 year)	-	1,138	-	-	-	-	-	-	-	-	-	-	-
Distribution Revenue on Prior Years Customer Attachments (full year)	-	-	2,276	2,276	2,276	2,276	2,276	2,276	2,276	2,276	2,276	2,276	2,276
Total Distribution Revenue for the Year - Large Customer #2	-	<u>1,138</u>	<u>2,276</u>	<u>2,276</u>	<u>2,276</u>	<u>2,276</u>	<u>2,276</u>	<u>2,276</u>	<u>2,276</u>	<u>2,276</u>	<u>2,276</u>	<u>2,276</u>	<u>2,276</u>
SES Revenue Rate (\$/m3)	0.23	0.23	0.23	0.23	0.23	0.23	0.23	0.23	0.23	0.23	0.23	0.23	0.23
SES Revenue on Current Year Customer Attachments (1/2 year)	-	2,422	-	-	-	-	-	-	-	-	-	-	-
SES Revenue on Prior Years Customer Attachments (full year)	-	-	4,844	4,844	4,844	4,844	4,844	4,844	4,844	4,844	4,844	4,844	4,844
Total SES Revenue for the Year - Large Customer #2	-	<u>2,422</u>	<u>4,844</u>	<u>4,844</u>	<u>4,844</u>	<u>4,844</u>	<u>4,844</u>	<u>4,844</u>	<u>4,844</u>	<u>4,844</u>	<u>4,844</u>	<u>4,844</u>	<u>4,844</u>
Total Distribution + SES Revenue - Large Customer #2	-	<u>3,560</u>	<u>7,120</u>	<u>7,120</u>	<u>7,120</u>	<u>7,120</u>	<u>7,120</u>	<u>7,120</u>	<u>7,120</u>	<u>7,120</u>	<u>7,120</u>	<u>7,120</u>	<u>7,120</u>
Total Project Distribution + SES Revenue	23,612	89,600	143,637	162,559	174,542	185,037	195,531	205,501	215,470	224,915	229,638	213,824	198,011

ENBRIDGE GAS INC.

Answer to Interrogatory from
Environmental Defence ("ED")

INTERROGATORY

Reference:

Exhibit E, Tab 1, Schedule 1, Attachment 2

Question(s):

- (a) Please confirm that home owners are eligible for up to \$5,000 grants and \$40,000 in interest free loans from the federal government for qualifying cold climate air source heat pump installations.
- (b) Please provide any studies or analysis that Enbridge has completed on the impact of the above-references \$5,000 grant and interest free loans for air source heat pumps on the likely number of customers attaching to the proposed pipeline.
- (c) Please provide any studies or analysis that Enbridge has completed on the impact of current high gas prices on the likely number of customers attaching to the proposed pipeline.

Response

- (a) Please see the response at EB-2022-0249 Exhibit I.ED.17 (a).
- (b) Please see the response at EB-2022-0249 Exhibit I.ED.17 (b).
- (c) Please see the response at EB-2022-0249 Exhibit I.ED.17 (c).

ENBRIDGE GAS INC.

Answer to Interrogatory from
Environmental Defence (“ED”)

INTERROGATORY

Reference:

Exhibit E, Tab 1, Schedule 1

Question(s):

- (a) Please confirm that Canada’s 2030 Emissions Reduction Plan includes a plan for carbon emissions associated with buildings to decline by 41% by 2030 from 2019 levels (to 53 CO₂e from 91 CO₂e) and that it plans for a 22% reduction by 2026 from 2019 levels (to 71 CO₂e from 91 CO₂e).¹ If not, please explain.
- (b) Please confirm that Canada’s 2030 Emissions Reduction Plan has formal legal status under s. 9 of the *Canadian Net-Zero Emissions Accountability Act* in relation to the legally binding targets under that Act.² If not, please explain.
- (c) Please confirm that Canada has committed to net-zero emissions from electricity generation by 2035. If not, please explain.

Response

- (a) Please see the response at EB-2022-0249 Exhibit I.ED.18 part (a).
- (b) Please see the response at EB-2022-0249 Exhibit I.ED.18 part (b).
- (c) Please see the response at EB-2022-0249 Exhibit I.ED.18 part (c).

¹ <https://www.canada.ca/en/environment-climate-change/news/2022/03/2030-emissions-reduction-plan--canadas-next-steps-for-clean-air-and-a-strong-economy.html>

² *Canadian Net-Zero Emissions Accountability Act*, s. 9.

ENBRIDGE GAS INC.

Answer to Interrogatory from
Environmental Defence (“ED”)

INTERROGATORY

Reference:

Exhibit E, Tab 1, Schedule 1

Question(s):

(a) Please confirm that the following chart accurately depicts the emissions reductions from buildings per Canada’s 2030 Emissions Reduction Plan.³ If not, please prepare a chart that Enbridge believes is accurate:

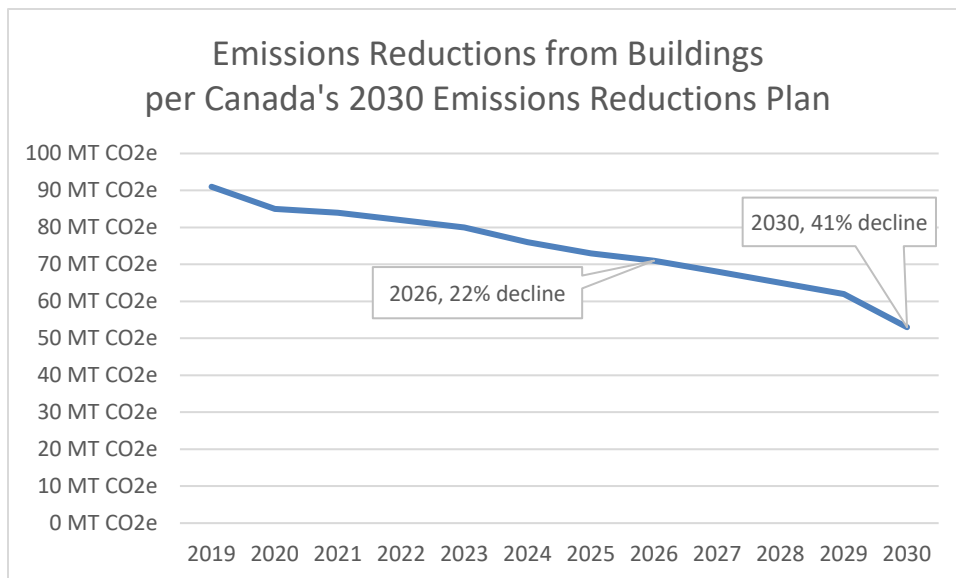

³ For the underlying numbers, see here: [2030 Emissions Reduction Plan – Canada's Next Steps for Clean Air and a Strong Economy](#) (link).

(b) Does Enbridge agree that Canada's 2030 Emissions Reduction Plan is likely to impact the customer attachment forecast through future policies that cause some customers to choose electric heat pumps over gas? If not, please explain.

Response

(a) Please see the response at EB-2022-0249 Exhibit I.ED.19 part (a).

(b) Please see the response at EB-2022-0249 Exhibit I.ED.19 part (b).

ENBRIDGE GAS INC.

Answer to Interrogatory from
Environmental Defence (“ED”)

INTERROGATORY

Reference:

Exhibit E, Tab 1, Schedule 1

Question(s):

- (a) Please provide a list of grants and loans available to customers in the proposed project area to install cold climate air source heat pumps.
- (b) Please provide a list of grants and loans available to Indigenous customers living on reserve in the proposed project area to install cold climate air source heat pumps.
- (c) Please confirm whether each of the following statements is true. If not, please explain why:
- i. The federal government is now providing \$5,000 incentives for customers to switch to high-efficiency electric heat pumps as part of its Greener Homes Grant;⁴
 - ii. The federal government is now providing an *additional* \$5,000 in incentives for customers to switch from oil to high-efficiency electric heat pumps if they earn a median income or lower (e.g. \$122,000 after-tax income for a family of 4 in Ontario) through the Oil to Heat Pump Affordability Program;⁵ and
 - iii. The federal government is now providing up to \$40,000 in interest free loans, which can be put towards conversions to electric heat pumps, and not gas equipment, through the Greener Homes Loan.⁶
- (d) Further to (b)(ii) above, please provide a table showing the median income for Ontario that serves as the eligibility threshold for the Oil to Heat Pump Affordability Program?

⁴ <https://natural-resources.canada.ca/energy-efficiency/homes/canada-greener-homes-initiative/canada-greener-homes-grant/canada-greener-homes-grant/23441>

⁵ <https://natural-resources.canada.ca/energy-efficiency/homes/canada-greener-homes-initiative/oil-heat-pump-affordability-program-part-the-canada-greener-homes-initiative/24775>

⁶ <https://natural-resources.canada.ca/energy-efficiency/homes/canada-greener-homes-initiative/canada-greener-homes-loan/24286>

- (e) Please provide an estimate of the number and percent of residents in the project area that would be eligible for Oil to Heat Pump Affordability Program. This could be done, for example, based on statistics for the percent households at or below the eligibility threshold in the area or region.
- (f) Please compare the cost of converting from oil to (i) gas versus (ii) an electric cold climate heat pump, accounting for two rebates noted above.

Response

(a) – (e)

Please see the response at EB-2022-0249 Exhibit I.ED.20 parts (a) – (d).

(f) Please see the response at EB-2022-0249 Exhibit I.ED.20 part (e).

ENBRIDGE GAS INC.

Answer to Interrogatory from
Environmental Defence (“ED”)

INTERROGATORY

Reference:

Exhibit E, Tab 1, Schedule 1

Question(s):

- (a) Please confirm how much additional annual subsidy individuals and families qualified under the Ontario Electricity Support Program can receive if they heat their home with electricity?
- (b) Please provide an estimate of the number and percent of residents in the project area that would be eligible for the Ontario Electricity Support Program. This could be done, for example, based on statistics for the percent of households receiving social assistance.
- (c) Please describe any electricity grants and subsidies available to Indigenous residents on reserves in Ontario.

Response

(a) – (c)

As a natural gas utility Enbridge Gas is not in a position to provide information regarding electricity subsidies or related support programs which the Company does not administer. The Company understands that information regarding the same is publicly available via the following OEB webpage:

<https://ontarioelectricitysupport.ca/FAQ>

ENBRIDGE GAS INC.

Answer to Interrogatory from
Environmental Defence (“ED”)

INTERROGATORY

Reference:

Exhibit E, Tab 1, Schedule 1

Question(s):

- (a) Does Enbridge agree that government policies or market forces related to decarbonization *could* impact the customer attachment or revenue forecasts? If not, please justify the response.
- (b) What are the lifetime volumes of gas (m3) and carbon emissions (CO₂e) corresponding to the 40-year customer attachment and revenue forecasts in relation only to emissions from end-use combustion?
- (c) What are the lifetime carbon emissions (CO₂e) corresponding to the 40-year customer attachment and revenue forecasts in relation only to upstream emissions (i.e. extraction and transportation)?
- (d) In EB-2020-0066, Exhibit JT1.714, Enbridge estimated 14 gCO₂e/MJ related to upstream extraction, processing, transportation and distribution of gas.⁷ Does Enbridge still believe this is the best estimate of upstream emissions? If not, please provide Enbridge’s best estimate of upstream emissions.
- (e) What are the lifetime carbon emissions (CO₂e) corresponding to the 40-year customer attachment and revenue forecasts in relation only to unburned methane from customer equipment (i.e. extraction and transportation)?⁸

⁷ See page 398: <http://www.rds.oeb.ca/HPECMWebDrawer/Record/680679/File/document>

⁸ Any of the following sources could be used as an emissions factor: Quantifying Methane Emissions from Natural Gas Water Heaters ([link](#)); Unburned Methane Emissions from Residential Natural Gas Appliances ([link](#)); An Estimate of Natural Gas Methane Emissions from California Homes ([link](#)); Beyond-the-Meter: Unaccounted Sources of Methane Emissions in the Natural Gas; Distribution Sector ([link](#)); Methane and NO_x Emissions from Natural Gas Stoves, Cooktops, and Ovens in Residential Homes ([link](#)).

- (f) What is Enbridge's best estimate of the emissions (gCO₂e/MJ & tCO₂e/m³) arising from unburned methane emissions from customer equipment?
- (g) Please confirm that the methane emissions cited in the following reference are only the methane emissions from *combustion*, not from leaks, and if Enbridge disagrees, please explain with excerpts: Ontario Ministry of the Environment and Climate Change. (2017, November). Guideline for Quantification, Reporting and Verification of Greenhouse Gas Emissions. Table 20-3 and Table 20-4. https://prod-environmental-registry.s3.amazonaws.com/2018-01/013-1457_d_Guide.pdf.
- (h) What are the emissions from the combustion of gas in Ontario (gCO₂e/MJ & tCO₂e/m³)?

Response

- (a) No. The Project-specific attachment/revenue forecast(s) is based on the current known energy preferences expressed by actual residents and business-owners within the Project area, which inherently incorporate all factors including financial and non-financial considerations. The Company has no reason to believe that the attachment forecast is inaccurate. Please also see the response at Exhibit I.ED.19 part (b).

Enbridge Gas also notes that the market research undertaken in Q3/Q4 2022, set out at Exhibit B, Tab 1, Schedule 1, Attachment 3, indicates that of the residents "likely" to convert to natural gas if made available, 84% would consider doing so within three years of natural gas becoming available, and the remaining 16% would do so after three years.

- (b) , (c) and (e)
Please see the response at EB-2022-0249 Exhibit I.ED.22 parts (b), (c) and (e).
- (d) Please see the response at EB-2022-0249 Exhibit I.ED.22 part (d).
- (f) Please see the response at EB-2022-0249 Exhibit I.ED.22 part (e).
- (g) Please see the response at EB-2022-0249 Exhibit I.ED.22 part (g).
- (h) Please see the response at EB-2022-0249 Exhibit I.ED.22 part (h).

ENBRIDGE GAS INC.

Answer to Interrogatory from
Environmental Defence (“ED”)

INTERROGATORY

Reference:

Exhibit E, Tab 1, Schedule 1

Question(s):

- (a) Is the price of gas and/or the incentives available for electric heat pumps impacting the customer attachments in community expansion projects? Please explain the answer.
- (b) To help us explore the question in (a), please complete the following tables and prepare a chart for each showing the trendline. For the second table, please divide the annual forecast by 12 to generate a monthly forecast figure.

Customer Attachments in Community Expansion Locations by Month				
	Jan 2020	Feb 2020	...	Dec 2022
Number of customer attachments				

Customer Attachments in Community Expansion Locations by Month Percent of Forecast				
	Jan 2020	Feb 2020	...	Dec 2022
Number of customer attachments as % of forecast				

Response

- a) Please see the response at EB-2022-0249 Exhibit I.ED.23 part (a).

b) Please see the response at EB-2022-0249 Exhibit I.ED.23 part (b).

ENBRIDGE GAS INC.

Answer to Interrogatory from
Environmental Defence (“ED”)

INTERROGATORY

Reference:

Exhibit E, Tab 1, Schedule 1

Question(s):

- (a) What is the annual average consumption (m³) and annual average distribution revenue (\$) per residential customer assumed by Enbridge in this proceeding?
- (b) What is the annual average consumption (m³) and annual average distribution revenue (\$) per residential customer being realized by Enbridge in its other community expansion projects? Please provide all underlying calculations. If possible, please make an adjustment for customers attaching mid-year.

Response

- (a) Average residential customer consumption varies depending on the square footage of the home; the standard residential normalized average consumption used in the Project economic analysis is 2,320 m³/year.

The annual average distribution revenue for one residential customer using 2,320 m³/year is \$516. The annual average SES revenue for one residential customer using 2,320 m³/year is \$534.

- (b) Please see the response to EB-2022-0249 Exhibit I.ED.24 part b).

ENBRIDGE GAS INC.

Answer to Interrogatory from
Environmental Defence (“ED”)

INTERROGATORY

Reference:

Exhibit E, Tab 1, Schedule 1

Question(s):

- (a) With respect to the revenue generated in the first 10 years, does Enbridge or do ratepayers bear the risk of average use being lower than forecast?
- (b) With respect to the revenue generated in the final 30 years, does Enbridge or do ratepayers bear the risk of average use being lower than forecast?
- (c) Please describe how regulatory adjustments relating to average use interact with the customers attached through community expansions. Please address both the first 10 years and final 30 years.

Response

- (a) – (c)
Please see the response to EB-2022-0249 Exhibit I.ED.25.

ENBRIDGE GAS INC.

Answer to Interrogatory from
Environmental Defence (“ED”)

INTERROGATORY

Reference:

Exhibit E, Tab 1, Schedule 1

Question(s):

(a) Please indicate how much revenue would need to be collected from customers over the final 30 years of this project to cover outstanding capital costs and ongoing O&M costs. Please provide all underlying calculations.

(b) Please confirm whether the following table is accurate, and if not, provide an accurate version:

Required Revenue per Project Discounted Cash Flow Tables⁹				
(\$,000)				
	Selwyn	Mohawks of the Bay of Quinte First Nation	Hidden Valley	Total
SES Revenue	\$4,477	\$4,252	\$2,188	\$10,917
Distribution Revenue	\$2,418	\$3,672	\$2,099	\$8,189
Total Revenue	\$6,895	\$7,924	\$4,287	\$19,106
Years 11-40				
SES Revenue	\$2,970	\$3,354	\$1,800	\$8,124
Years 11-40				
Distribution Revenue	\$3,349	\$2,953	\$1,710	\$8,012
Years 11-40 Revenue	\$6,319	\$6,307	\$3,510	\$16,136
Percent of revenue in years 11-40	91.6%	79.6%	81.9%	84.5%

⁹ EB-2022-0156, Exhibit E, Tab 1, Schedule 1, Attachment 2; EB-2022-0248, Exhibit E, Tab 1, Schedule 1, Attachment 2; EB-2022-0249, Exhibit E, Tab 1, Schedule 1, Attachment 2.

Response

- (a) The combined SES and distribution revenue required to be collected over the final 30 years of the proposed Project to cover outstanding capital costs and ongoing O&M costs is \$6,307,000.
- (b) Please see the response at EB-2022-0249 Exhibit I.ED.26 part (b).

ENBRIDGE GAS INC.

Answer to Interrogatory from
Environmental Defence (“ED”)

INTERROGATORY

Reference:

Exhibit I, Tab 1, Schedule 1

Question(s):

- (a) Please provide a route map indicating which portions of the pipeline would be on private or public land.
- (b) Please provide a map showing the trees that will need to be removed for the pipeline construction.
- (c) Please provide satellite images of each portion of the pipe with an overlay showing where the trench will be dug for the pipeline. Please provide this as a high-resolution image so that a viewer can zoom in to see the impact on properties and vegetation along each portion of the pipeline route.

Response

- (a) No permanent easement on private land is expected to be required for the proposed pipeline as the preferred route (“PR”) is entirely within the public road allowance.
- (b) Enbridge Gas cannot confirm at this time whether or not tree removal will be required for the Project and will not be in a position to confirm the same until engineering designs are finalized, closer to the commencement of Project construction. If tree removal is required, Enbridge Gas will obtain all required permits and authorizations and will follow all established mitigation measures and applicable protocols established by the MBQ prior to commencement of construction.
- (c) The proposed pipeline(s) will be constructed by a combination of horizontal directional drill and open cut excavations where applicable. The final detailed pipeline design (including proposed running line) is currently in development as Enbridge Gas continues to gather information from field studies and consultation

with applicable permitting agencies for approval. Therefore, the level of detailed imaging requested by ED is not available at this time.

The Environmental Alignment Sheets provided in the Environmental Report show the sensitive features in the Project Study Area.¹

These alignment sheets are used during the design and construction stages to ensure appropriate mitigation measures are developed and implemented during the execution of the Project to mitigate potential impacts to sensitive features such as species at risk habitat, mature vegetation, and watercourse crossings.

¹ Exhibit F, Tab 1, Schedule 1, Attachment 1, pp. 55-64, Figure 9 Maps 1 to 10

ENBRIDGE GAS INC.

Answer to Interrogatory from
Environmental Defence (“ED”)

INTERROGATORY

Reference:

Exhibit I, Tab 1, Schedule 1

Question(s):

(a) Would Enbridge agree to the following condition of approval? If not, please explain why not and provide alternative wording for a commitment that Enbridge would make.

“The Applicant shall provide potential customers with a comparison of the average annual energy costs and lifetime all-in costs of converting to gas versus converting to a cold climate air source heat pump.”

(b) Please provide a copy of:

- (i) All promotional or informational materials sent to customers in community expansion areas that have connected to the gas system in the past three years, including materials sent by mail, email, or social media;
- (ii) A copy of all newspaper and online advertisements relating to switching to gas in the past three years; and
- (iii) A copy of all Enbridge website pages relating to switching to gas.

(c) For the items in (b) that are undated, please indicate the date range during which they were sent to customers or published.

(d) Please provide a copy of all Enbridge communication plans or communication strategy documents relating to community expansions or switching to gas more generally.

Response

(a) Please see the response at EB-2022-0249 Exhibit I.ED.28 part (a).

(b) and (c)

Please see the response at EB-2022-0249 Exhibit I.ED.28 parts (b) and (c).

(d) Please see the response at EB-2022-0249 Exhibit I.ED.28 part (d).

ENBRIDGE GAS INC.

Answer to Interrogatory from
Federation of Rental-housing Providers of Ontario ("FRPO")

INTERROGATORY

Reference:

Exhibit C, Tab 1, Schedule 1, Exhibit D, Tab 1, Schedule ,
Exhibit B, Tab 1, Schedule 1, Page 8, Table 2
AND EB-2022-0081 Natural Gas Facilities Handbook, p. 32-33

Preamble:

We would like to understand the assessment of the project need and alternatives considered in this application. The referenced pages of the Natural Gas Facilities Handbook provide the Board's expectation for information to filed in respect of Project Need and Alternatives. The content of the application does not provide the reader with the necessary understanding to determine the appropriateness of the application.

Question(s):

Please provide a major main map (NPS 4 or larger) that includes:

- a) the surrounding 550 kPa system(s)
- b) the proposed project in its entirety including the NPS 2 proposed
- c) any additional pipelines higher than 560 kPa pressure lines with 30 km of the project area including the pipe that feeds station that is proposed to be rebuilt

Response

a) – c)

Please see Attachment 1 to this response. Pipelines displayed on the map that appear to be isolated from the network are connected by pipelines either less than NPS 4-inch or 550 kPa.

MOHAWKS OF THE BAY OF QUINTE & SHANNONVILLE

NPS 4" OR LARGER WITHIN 30km

Filed: 2023-05-02, EB-2022-0248, Exhibit I.FRPO.1, Attachment 1, Page 1 of 1

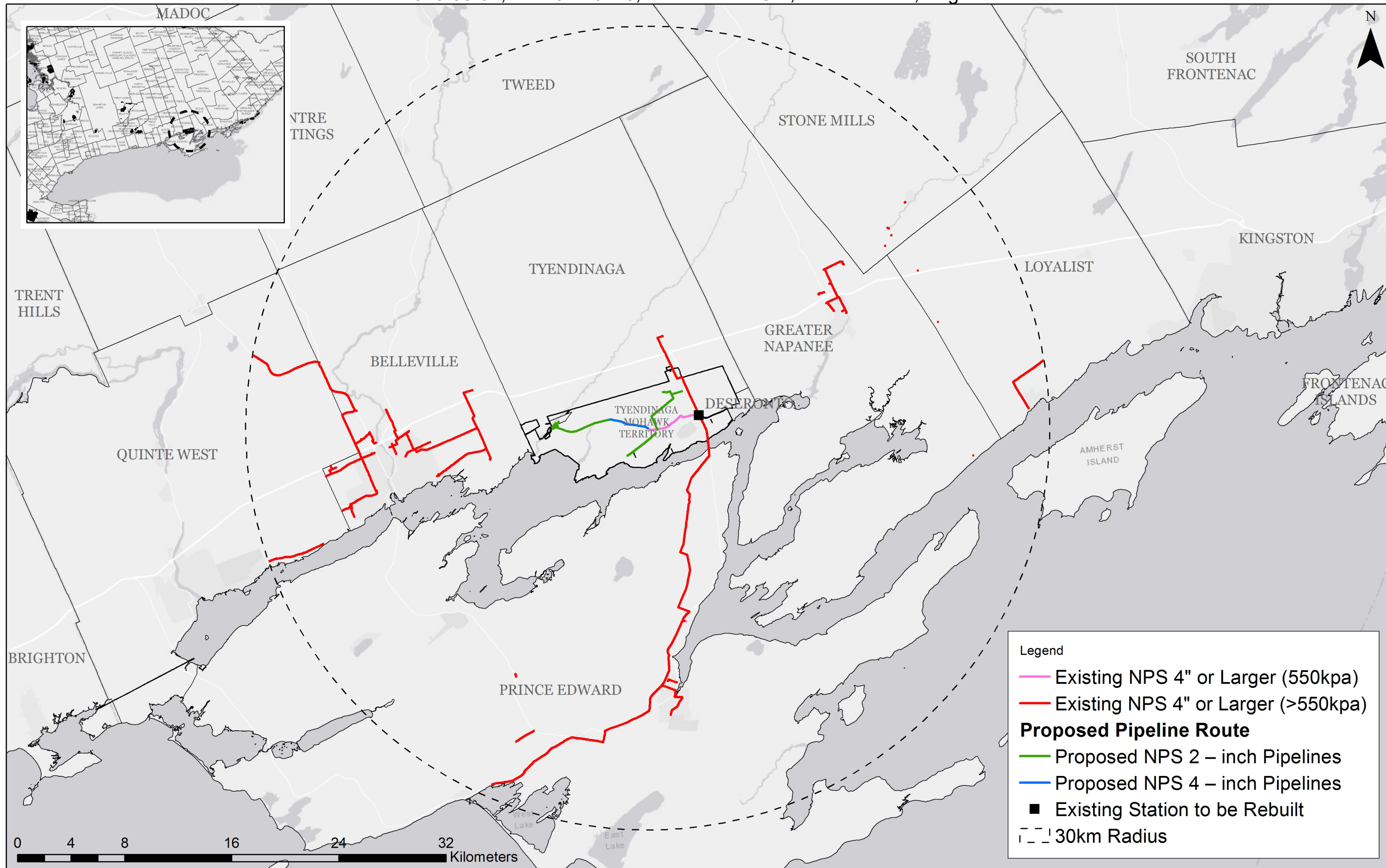

ENBRIDGE GAS INC.

Answer to Interrogatory from
Federation of Rental-housing Providers of Ontario ("FRPO")

INTERROGATORY

Reference:

Exhibit C, Tab 1, Schedule 1, Exhibit D, Tab 1, Schedule ,
Exhibit B, Tab 1, Schedule 1, Page 8, Table 2
AND EB-2022-0081 Natural Gas Facilities Handbook, p. 32-33

Preamble:

We would like to understand the assessment of the project need and alternatives considered in this application. The referenced pages of the Natural Gas Facilities Handbook provide the Board's expectation for information to filed in respect of Project Need and Alternatives. The content of the application does not provide the reader with the necessary understanding to determine the appropriateness of the application.

Question(s):

Using the forecasted customer additions in Table 2, for each year and each customer type, please provide the peak winter loads associated with the respective customer classes.

Response

The peak winter loads associated with Table 2 are set out in Table 1 below:

<u>Table 1: Peak Winter Demands (m³/hr)</u>											
Year	2024	2025	2026	2027	2028	2029	2030	2031	2032	2033	Total
Residential	49.5	44	16.5	12.1	8.8	11	9.9	11	9.9	9.9	182.6
Commercial	0	116.1	29.2	10.1	3.1	3.1	0	0	0	0	161.6
Total	49.5	160.1	45.7	22.2	11.9	14.1	9.9	11	9.9	9.9	344.2

ENBRIDGE GAS INC.

Answer to Interrogatory from
Federation of Rental-housing Providers of Ontario ("FRPO")

INTERROGATORY

Reference:

Exhibit C, Tab 1, Schedule 1, Exhibit D, Tab 1, Schedule ,
Exhibit B, Tab 1, Schedule 1, Page 8, Table 2
AND EB-2022-0081 Natural Gas Facilities Handbook, p. 32-33

Preamble:

We would like to understand the assessment of the project need and alternatives considered in this application. The referenced pages of the Natural Gas Facilities Handbook provide the Board's expectation for information to filed in respect of Project Need and Alternatives. The content of the application does not provide the reader with the necessary understanding to determine the appropriateness of the application.

Question(s):

Please provide the network analysis of the peak day of the 550 kPa system for the Winter of 2022/23 providing the winter station settings and pressures and the locations at low points in the respective systems.

- a) Please provide the network analysis of the peak day for the Winter of 2022/23 or Winter of 2023/24 with the proposed project in place using the same station settings.
 - i) Please provide the winter peak load forecasted to be added with the proposed project for both year 1 and year 10 assuming no additional growth from the existing system.
 - ii) Please provide the pressure and location of the low points in the respective systems.
- b) Please provide the same network analysis described in a) including subsections in i) and ii) using NPS 2 instead of NPS 4 for the proposed project sections.

Response

The network analysis for the 550 kPa system prior to the construction of the proposed Project and prior to the rebuild of the station for winter 2022/23 is as follows:

- Total Flow: 180 m³/h
 - Maximum Operating Pressure: 550 kPa
 - Station Setting: 380 kPa
 - Modelled Pressure at Low Point: 373 kPa
 - Location: Intersection of York St. and Sadie's Lane
- a) The network analysis for the 550 kPa system for Winter 2023/24 (year 1 of the Project) once the station is rebuilt is as follows:
- Total Flow: 230 m³/hr
 - Maximum Operating Pressure: 550 kPa
 - Station Setting: 485 kPa
 - Modelled Pressure at Low Point: 477 kPa
 - Location: Intersection Gore St. and Queen St.
- i) Please see the response to Exhibit I.FRPO.2.
- ii) The pressure at the low point in the 550 kPa system once the station is rebuilt is as follows:
- Station Setting: 485 kPa
 - Year 1 Low Point Pressure: 477 kPa
 - Year 1 Low Point Pressure Location: Near the intersection Gore St. and Queen St.
 - Year 10 Low Point Pressure: 346 kPa
 - Year 10 Low Point Pressure Location: Near Gore St. and Queen St.
- b) The network analysis for the 550 kPa system for Winter 2023/24 (year 1 of the project) once the station is rebuilt with all NPS 2 pipe is as follows:
- Total Flow: 230 m³/hr
 - Maximum Operating Pressure: 550 kPa
 - Station Setting: 485 kPa
 - Modelled Pressure at Low Point: 474 kPa
 - Location: Intersection Gore St. and Queen St.
- i) Please refer to the response to Exhibit I.FRPO.2.

ii) The pressure at the low point in the 550 kPa system once the station is rebuilt with all NPS 2 pipe is as follows:

- Station Setting: 485 kPa
- Year 1 Low Point Pressure: 474 kPa
- Year 1 Low Point Location: Near the intersection Gore St. and Queen St.
- Year 10 Low Point Pressure: 189 kPa
- Year 10 Low Point Pressure Location: Near Gore St. and Queen St.

ENBRIDGE GAS INC.

Answer to Interrogatory from
Federation of Rental-housing Providers of Ontario ("FRPO")

INTERROGATORY

Reference:

Exhibit C, Tab 1, Schedule 1, Exhibit D, Tab 1, Schedule ,
Exhibit B, Tab 1, Schedule 1, Page 8, Table 2
AND EB-2022-0081 Natural Gas Facilities Handbook, p. 32-33

Preamble:

We would like to understand the assessment of the project need and alternatives considered in this application. The referenced pages of the Natural Gas Facilities Handbook provide the Board's expectation for information to filed in respect of Project Need and Alternatives. The content of the application does not provide the reader with the necessary understanding to determine the appropriateness of the application.

Question(s):

Using the results of the comparative analysis requested for the proposed NPS 4 vs the alternative NPS 2, please provide EGI's views on the pipe sizing proposed and the ability of NPS 2 as an appropriate alternative.

Response

With the entire Project installed as NPS 2, the low pressure in year 10 approaches minimum allowable pressures based on the forecasted attachments.¹ The model demonstrates it is not feasible to install the entire Project as NPS 2, as system pressures fall below minimum allowable pressures with 100% attachment rate of the project.²

¹ Exhibit I.FRPO.3 part b), sub-part ii)

² Exhibit I.STAFF.2 part f)

ENBRIDGE GAS INC.

Answer to Interrogatory from
Federation of Rental-housing Providers of Ontario ("FRPO")

INTERROGATORY

Preamble:

Paragraph 5 in the Exhibit D reference speaks to a station rebuild being proposed in conjunction with the proposed project. We would like to understand the alternatives considered.

Question(s):

Please provide the date the existing station was built.

- a) Please provide the date and the specific modifications made to the station since the initial installation.
- b) Please provide the existing station as-built drawing that provides equipment details.
 - i) If an as-built drawing is not available, please provide a schematic showing pipe layouts and sizes and details on all operating components beyond pipe and valves (e.g., regulator model, orifice size (if appropriate), filter, relief valve, etc.)
 - ii) Please provide the current design load fed by the station
 - iii) Please provide actual minimum inlet pressure experienced at the station in the last 3 years.
- c) Is there any other station feeding the system beside the station proposed to be replaced? If yes, please provide the equipment details of that station.
- d) Please provide a schematic or drawing of the proposed replacement station, the design capacity and the cost estimate for the station only.

Response

The existing station was commissioned into service in May 2016.

- a) There have not been any modifications made to this station since its initial installation.
- b)
 - i) Please see Attachment 1 to this response for the standard station design and details of components installed at the Deseronto Pressure Regulating Station ("PRS").
 - ii) The current design load fed by the station is 180 m³/hr (prior to the proposed Project).
 - iii) Historical inlet pressure data is not available, as the station is a small distribution station that does not have inlet pressure monitoring. The station feeds an existing system with only 180 m³/hr peak demand.
- c) No other station feeds the system besides the Deseronto PRS proposed to be replaced.
- d) The drawing for the proposed replacement station is not available at this time as it is being reviewed by stakeholder to ensure constructability and all operational concerns have been addressed. The design capacity of the proposed replacement station will be ~1,000 m³/h based on preliminary designs. The estimated cost for the new station is \$80,000 for materials only.

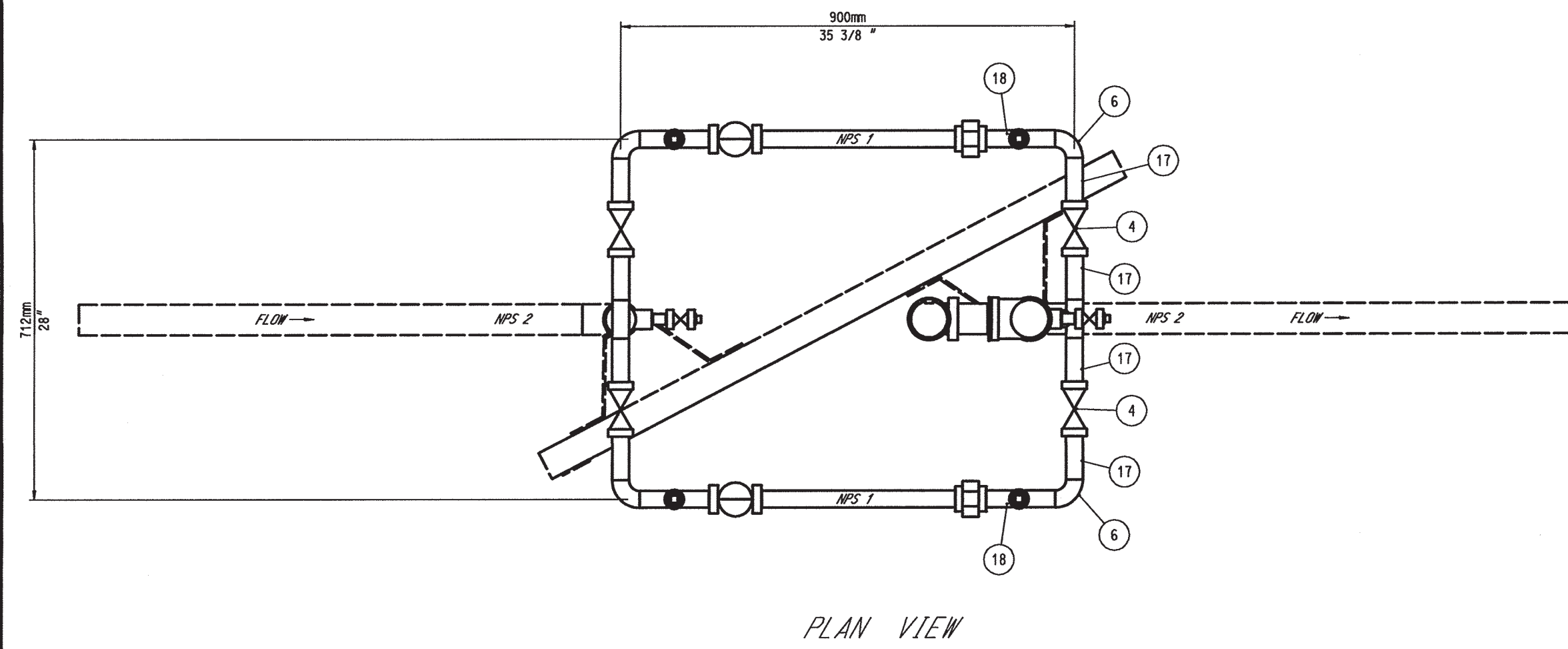

PLAN VIEW

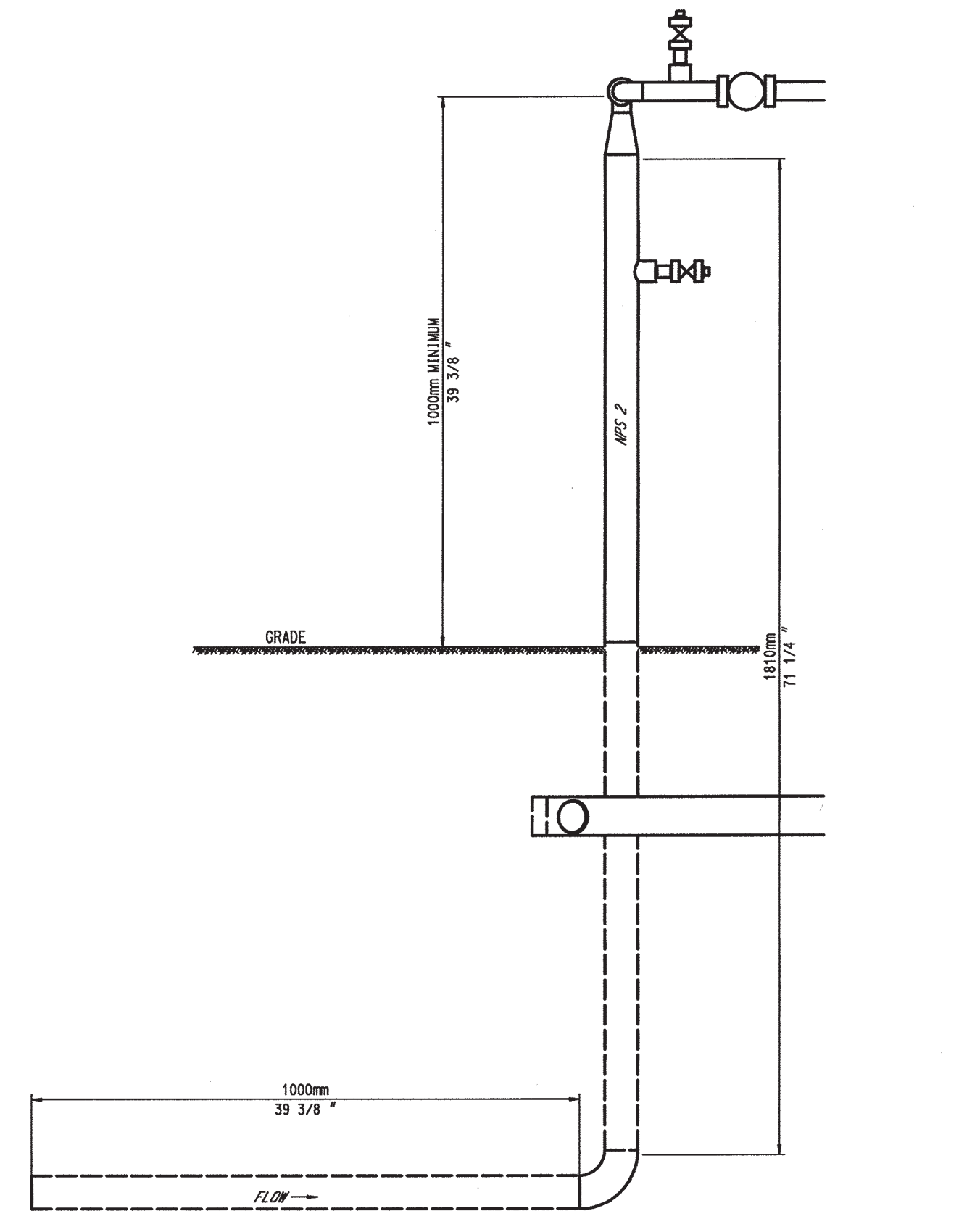

INLET ELEVATION VIEW

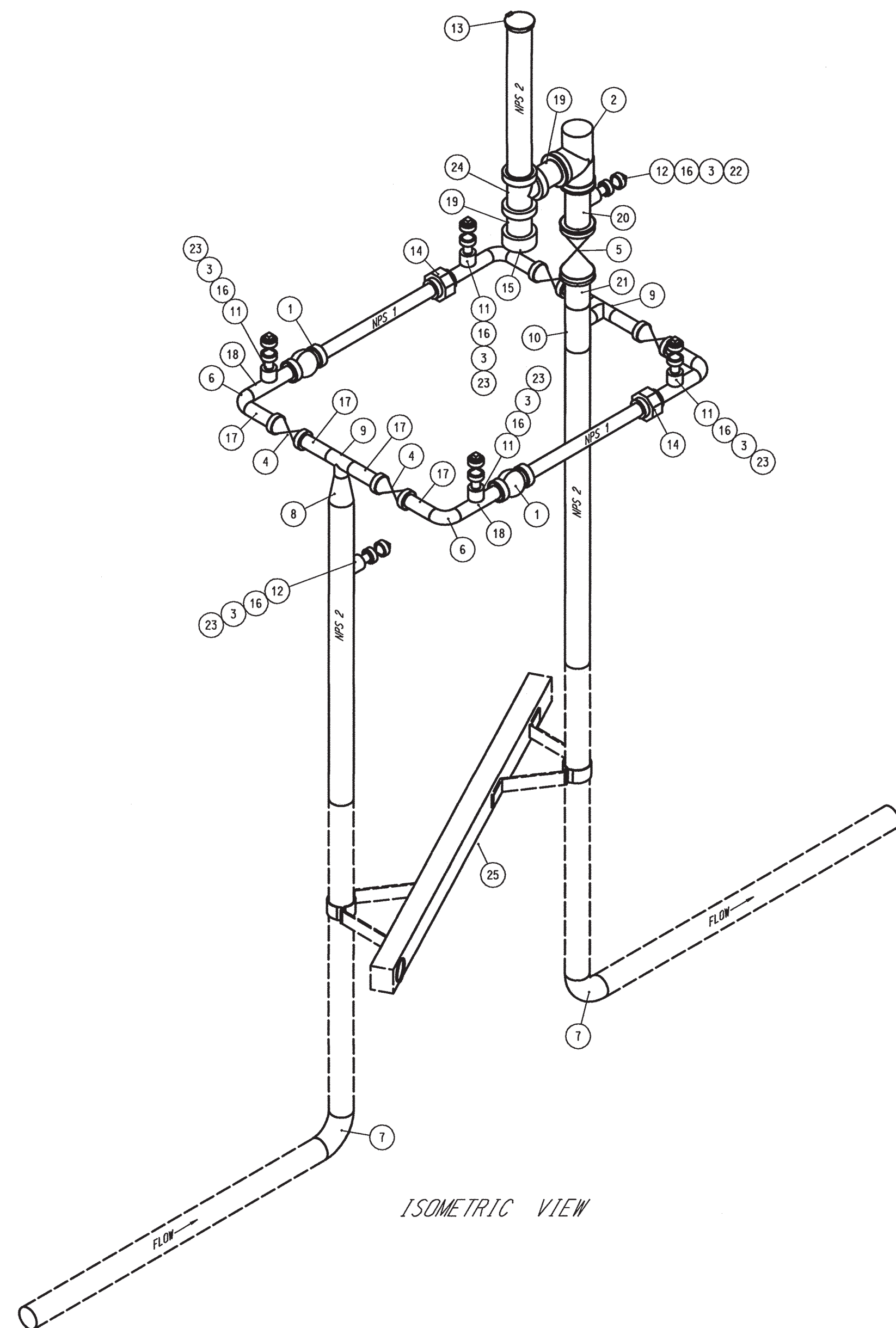

ISOMETRIC VIEW

Item No	Material No	Qty	Size	Description
PLANT ITEMS				
1		2	1	REGULATOR FISHER 627 NPT 1 x 1, ORIFICE TO BE SPECIFIED BY STATION ENGINEERING, c/w BLUE SPRING #10B3078 X012; 241 TO 550 kPa RANGE
2		1	2	RELIEF VALVE FISHER 1808A-6358B NPT 2 x 2, c/w RED SPRING #1K7485 27202; 241 TO 861 kPa RANGE

FISHER 627 REGULATORS ARE FITTED WITH 4.8mm (3/16 in.) ORIFICE

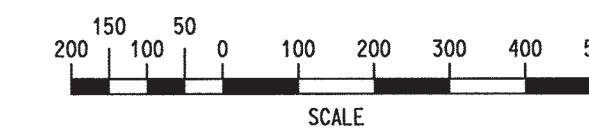

ALL DIMENSIONS ARE IN MILLIMETRES

	FOR INFORMATION ONLY
	PRELIMINARY
	ISSUED FOR BID
	ISSUED FOR CONSTRUCTION
	AS BUILT
	AS BUILT BY:
	CHECKED BY:

ENGINEERING APPROVAL:

No.	DATE	BY	APP'D	REMARKS
REVISIONS				

uniongas
A Spectra Energy Company

STANDARD SMALL DISTRICT STATION
550/420 MOP OUTLET c/w FULL RELIEF
DUAL RUN 500 m³/h CAPACITY, 700 TO 3450 kPa INLET

DRAWN BY	DATE	PLLOT SPEC	1:10
CHECKED BY	DATE	CAD CODE	
APPROVED BY	DATE	FILE REVISION DATE	

Sheet No.	SYSTEM	DRAWING No.
1 OF 1	00	

ENBRIDGE GAS INC.

Answer to Interrogatory from
Federation of Rental-housing Providers of Ontario ("FRPO")

INTERROGATORY

Preamble:

Paragraph 5 in the Exhibit D reference speaks to a station rebuild being proposed in conjunction with the proposed project. We would like to understand the alternatives considered.

Question(s):

Please provide the design specifications including:

- a) Existing inlet pressure parameters: MOP and design minimum inlet
- b) The design capacities of the respective components under design conditions
- c) Please provide any alternatives considered to replace the orifices in the regulators or the regulators themselves to increase the capacity
 - i) Please provide the potential capacity from a regulator modification or replacement
 - ii) Please explain fully why this alternative was not proposed
- d) Please provide the fulsome assessment of the considerations to refurbish or modify the station as opposed to re-building.
 - i) Please provide any cost estimates prepared for the option of refurbishing or modifying the station.

Response

- a) Existing inlet pressure parameters are provided in Table 1.

Table 1: Station Parameters

Parameters	
Design Inlet Pressure	1,210 kPa
Inlet MOP	1,210 kPa
Design Minimum Inlet Pressure	875 kPa
Outlet MOP	550 kPa
Required Outlet Pressure	485 kPa
Required Flow	700 m ³ /h

- b) The existing station was evaluated to determine if it could meet the required design parameters. The design of the piping on the outlet of the station limits the capacity of this station to 500 m³/h. Therefore, the existing station cannot meet the Required Flow design parameter due to piping limitations.
- c) The existing regulators were evaluated, and it was determined that they would not be able to meet the Required Outlet Pressure due to droop (the decrease from setpoint at a given flow rate, expressed as a percentage of setpoint).
- i) Modification of the existing regulators would increase its capacity; however, the maximum sustainable outlet pressure of the station would be 412 kPa due to droop. Therefore, the existing regulators cannot meet the Required Outlet Pressure design parameter due to droop.
- ii) This alternative was not proposed as it did not meet the Required Outlet Pressure design parameters. In addition, the existing station piping limits the capacity of this station to 500m³/hr.
- d) When assessing the existing station, the following items were identified as needing to be addressed to meet the design parameters:
- Station piping modifications were required to meet the Required Flow design parameter (please also see the response to part b) above); and
 - Regulators would need to be replaced with pilot operated regulators to meet the Required Outlet Pressure design parameter (please also see the response to part c) above).

In considering the feasibility of replacing the existing regulators with pilot operated regulators it was determined that the existing regulator runs were not long enough to accommodate pilot operated regulators. Due to the extent of the upgrades required

to meet the design parameters with the existing station, it was decided that the station would need to be replaced with a new station.

- i) Due to the extent of the upgrades required to meet the design parameters with the existing station, it was decided that the station would need to be replaced with a new station. Therefore, a cost estimate for the required station modifications was not prepared.

ENBRIDGE GAS INC.

Answer to Interrogatory from
Federation of Rental-housing Providers of Ontario ("FRPO")

INTERROGATORY

Preamble:

Paragraph 5 in the Exhibit D reference speaks to a station rebuild being proposed in conjunction with the proposed project. We would like to understand the alternatives considered.

Question(s):

Please provide any assessment that EGI undertook of providing a Compressed Natural Gas station at a strategic location in the system as an initial IRP treatment to avoid or defer the rebuild of the station and/or downsize the NPS 4 to NPS 2.

a) If not done, please explain fully why not.

Response

Existing natural gas pipeline facilities with sufficient capacity to support the Project are already located within close proximity in the community, making the proposed Project the most cost-effective and reliable alternative. CNG was not considered a viable or an economically feasible supply alternative given that virtual pipeline assets (trailers, mother & daughter stations, etc.) would only add incremental and unnecessary costs compared to the proposed Project and would deliver natural gas supply at a higher cost to the community.

Furthermore, the OEB previously determined within its IRP Framework for Enbridge Gas that:¹

...given the goal of the Ontario Government's Access to Natural Gas legislation to extend gas service to designated communities, Enbridge Gas is not required to develop an IRP Plan or consider alternatives to the infrastructure facilities to meet this need.

¹ EB-2020-0091, Decision and Order, Appendix A, p. 10

The OEB reiterated this determination as it relates to the current proceeding in its Decision on Intervenor Evidence (April 17, 2023).

ENBRIDGE GAS INC.

Answer to Interrogatory from
Federation of Rental-housing Providers of Ontario ("FRPO")

INTERROGATORY

Reference:

Exhibit E, Tab 1, Schedule 1, p.1, Table 1, and Attachments 1 & 2

Question(s):

Please revise the cost estimates of Project in Table 1 using NPS 2 instead of the proposed sections of NPS 4.

- a) Please provide resulting PI of the project using the NPS 2 estimate by revising the economics in Attachment 1 & 2 using the NPS 2 estimate to show:
- i) Initial PI (without NGEF/ SES funding)
 - ii) PI with SES contributions
 - iii) Remaining shortfall (i.e., needed additional contribution to achieve PI of 1.0)

Response

Enbridge Gas respectfully declines to provide the results sought by FRPO for the Project using NPS-2 inch entirely. The Company does not support FRPO's hypothetical scenario as it is not supported by and does not appropriately consider system design or planning parameters and constraints. Please see the response at Exhibit I.FRPO.4 for comments on system sizing constraints and concerns/infeasibility of utilizing entirely NPS 2-inch PE pipeline for the Project design.

ENBRIDGE GAS INC.

Answer to Interrogatory from
Federation of Rental-housing Providers of Ontario ("FRPO")

INTERROGATORY

Reference:

Exhibit E, Tab 1, Schedule 1, p.1, Table 1, and Attachments 1 & 2

Question(s):

For projects included in the NGEF, please explain fully how the contributions are treated from a Discounted Cash Flow perspective including:

- a) Offset to initial capital like CIAC
- b) Impact on rate base (gross vs. net)
- c) Impact to CCA Tax Shield and resulting project benefits (i.e., who receives benefits)

Response

- a) NGEF contributions are treated in an identical manner to contributions in aid of construction ("CIAC"). They effectively reduce capital expenditures in the year(s) in which they are projected to be received.
- b) NGEF contributions serve to reduce net rate base.
- c) NGEF contributions serve to reduce the capital cost allowance ("CCA") tax shield. The benefits of the CCA tax shield flow to the Project and are factored into the calculation of the project PI and were included in the calculation of the required NGEF contributions.

ENBRIDGE GAS INC.

Answer to Interrogatory from
Federation of Rental-housing Providers of Ontario ("FRPO")

INTERROGATORY

Reference:

Exhibit E, Tab 1, Schedule 1, p.1, Table 1, and Attachments 1 & 2

Question(s):

Please clarify the impacts of the following: A residential customer signs up and receives natural gas service in year 1 and they stay connected for 10 years. That customer sells their property to a third party who converts the home to some form of electrical heating and water heating.

- a) Are there obligations on the property for the SES surcharge that transfers the obligation for some lump sum payment from either the new or previous owner?
- b) If not, would that expected shortfall of revenue be made up by the company in some deferral account or by included in rates subsequent rebasing proceeding? Please explain fully.

Response

- a) SES surcharge is attached to the property and is calculated based on the actual gas usage at the property. In the event the gas connection is terminated and gas is no longer being consumed, there will be no obligation to pay the SES surcharge in lump sum.
- b) Enbridge Gas assumes the risk of meeting the forecasted capital cost and revenues during the 10-year Rate Stabilization Period ("RSP"). Enbridge Gas has included the original forecasted Project capital cost and revenues in its 2024 Rate Rebasing application, any variances during the 10-year RSP will be Enbridge Gas' risk to bear. As part of a subsequent rate rebasing application, following the 10-year RSP, Enbridge Gas will provide the actual Project-specific capital cost and revenues (previous 10 years and remaining forecast) and may seek to recover any revenue requirement shortfall at that time.

ENBRIDGE GAS INC.

Answer to Interrogatory from
Pollution Probe (“PP”)

INTERROGATORY

Question(s):

- a) Please provide a copy of the project application details submitted for funding assistance as part of Phase 2 of the Government of Ontario’s Natural Gas Expansion Program (“NGEP”). If there are any differences between the project details (e.g. facilities, cost, customers, etc.) in the NGEP application and this Leave to Construct application, please explain the differences.
- b) Please provide a copy of the award/approval correspondence received from the NGEP for this project, including any conditions for funding.
- c) Is there a mandated timeframe under NGEP for completion of the proposed pipeline? If yes, please provide the relevant condition that dictates specific timing.

Response

- a) Please see the response to Exhibit I.STAFF.3.
- b) Please refer to the OEB's website to view the record of NGEP-related correspondence associated with the Project:

<https://www.oeb.ca/industry/policy-initiatives-and-consultations/potential-projects-expand-access-natural-gas>

Please also see O. Reg. 451/21 which outlines the funding amounts approved for NGEP-related projects.

<https://www.ontario.ca/laws/regulation/r21451>

Approved NGEP funding amounts are released via the IESO to Enbridge Gas following receipt of an order of the OEB granting leave to construct and the commencement of project construction, on a project-specific basis.

- c) Please refer to section 2(2) O. Reg. 24/19: Expansion of Natural Gas Distribution Systems (<https://www.ontario.ca/laws/regulation/190024>) which states:

The following rules apply to any project listed in Column 1 of the Table to Schedule 2 that requires a Board order under section 96 of the Act granting leave to construct a hydrocarbon line:

1. If the gas distributor fails to apply for the Board order on or before December 31, 2025, investments in the project are no longer eligible to be qualifying investments.

ENBRIDGE GAS INC.

Answer to Interrogatory from
Pollution Probe ("PP")

INTERROGATORY

Question(s):

- a) Do the 179 customers (166 residential and 13 commercial and industrial customers) represent all residential, commercial and industrial consumers along the proposed route? If not what is the full number of residential, commercial and industrial consumers along the proposed route?
- b) How many firm confirmations have been received from potential customers (please provide numbers by customer type, e.g. residential, commercial, industrial, etc.).
- c) What excess capacity is available in the proposed pipeline to service additional customers in the future beyond the 179 customers forecasted, if any?

Response

- a) Please see the response to Exhibit I.ED.4, part a).
- b) Enbridge Gas only commenced customer outreach in the affected community in January of 2023 (approximately 3 months ago). As of April 19, 2023, 8 service applications have been completed/received. Additionally, MBQ Chief and band council provided a letter of intent to convert all 24 band owned properties to natural gas.¹
- c) The system has a total excess capacity of 115 m³/hr, distributed evenly across the system to service additional customers in the future.

¹ Exhibit B, Tab 1, Schedule 1, Attachment 5

ENBRIDGE GAS INC.

Answer to Interrogatory from
Pollution Probe (“PP”)

INTERROGATORY

Question(s):

- a) Please confirm that all potential commercial and industrial customers along the route responded to the questionnaire and indicated they would like to connect to the project in year 1. If that is not correct, please provide a list of all the potential commercial and industrial customers and a copy of their responses.
- b) Please provide a load sheet for each commercial and industrial customer included in the project. If a load sheet is not available for a potential customer, please explain why.

Response

- a) Please see the results of the Mohawks of the Bay of Quinte & Tyendinaga Township Natural Gas Questionnaire (“Questionnaire”),¹ and the response to Exhibit I.STAFF.1, for discussion regarding the survey response rate and the nature of information gathered. Enbridge Gas cannot confirm which customers responded based on the data collected. However, the Company can confirm that potential commercial customers known at the time were included in the Questionnaire, with the exception of band-owned customers/buildings (as well as the single industrial customer as they are also band-owned) who are being dealt with as a whole, directly with the band. Band-owned commercial/industrial properties account for 6 of the commercial customers identified and all band-owned buildings are expected to attach, as indicated in the Letter of Support from MBQ.²
- b) Due to the size of the Project, and the timing and duration of Project scoping and pre-planning, individual load sheets for all commercial and industrial customers are not reasonably possible to complete. Rather, assumptions validated through the Company’s commercial load survey process are being used to assess Project feasibility and main sizing. Through the load survey process, some businesses may

¹ Exhibit B, Tab 1, schedule 1, Attachment 4

² Exhibit B, Tab 1, Schedule 1, Attachment 5

share high-level load information which is integrated into the preliminary scoping where applicable. Actual loads are obtained from the customer when they apply for gas with technical support from their HVAC contractor and are used to appropriately size and design the servicing infrastructure.

ENBRIDGE GAS INC.

Answer to Interrogatory from
Pollution Probe (“PP”)

INTERROGATORY

Question(s):

Is this proposed project included in the most current Enbridge Asset Management Plan (AMP) and Utility System Plan (USP)? If not, why not. If yes, please provide the references and documents (or links).

Response

Community Expansion (“CE”) projects are included within the USP as part of the System Access category of projects and associated budget totals.¹ All regulated utility projects are included in the USP.

The 2023-2032 AMP includes commentary on CE projects generally. Further, the proposed Project is included on the map displaying approved project locations.² However, as stated in the 2023-2032 AMP, specific CE project details and capital expenses are excluded from the AMP as they are not subject to optimization and follow separate project funding criteria.³

¹ EB-2022-0200, Exhibit 2, Tab 6, Schedule 1, p. 53

² EB-2022-0200, Exhibit 2, Tab 6, Schedule 2, p. 70, Figure 5.1-6

³ EB-2022-0200, Exhibit 2, Tab 6, Schedule 2, p. 73

ENBRIDGE GAS INC.

Answer to Interrogatory from
Pollution Probe ("PP")

INTERROGATORY

Question(s):

What OEB approvals other than the requested Leave to Construct are required for Enbridge to proceed with construction of this project? Please provide details on when Enbridge expects those approvals, if applicable.

Response

Please see the response to EB-2022-0249 Exhibit I.PP.6.

ENBRIDGE GAS INC.

Answer to Interrogatory from
Pollution Probe (“PP”)

INTERROGATORY

Question(s):

- a) How many questionnaires were handed out or delivered in total?
- b) How many door-to-door packages including the questionnaire were delivered?
- c) Why did Enbridge not engage a formal polling company (e.g. Forum Research or equivalent) for this project, similar to what has been done for other community expansion projects?

Response

- a) and b)
Please see the response to Exhibit I.Staff.1 .
- c) As stated in its pre-filed evidence at Exhibit B, Tab 1, Schedule 1, Pages 2-3:

After consulting with the MBQFN, the preferred method of gauging community interest in converting to natural gas within the MBQFN was in-person delivery both at the Fall Fair and door-to-door. The same method was also extended to the Township for consistency.

ENBRIDGE GAS INC.

Answer to Interrogatory from
Pollution Probe ("PP")

INTERROGATORY

Reference:

Questionnaire Results Table [Exhibit B, Tab 1, Schedule 1, Attachment 4]

Question(s):

- a) What number and percent of commercial and industrial potential customers completed the questionnaire?
- b) Is Enbridge extrapolating the 66/68 positive response rate across all potential residential, commercial and industrial customers? If not, please explain how Enbridge has extrapolated the questionnaire results to reach the 166 residential and 13 commercial/industrial forecasted.

Response

- a) Please see the response to Exhibit I.PP.3 part a).
- b) Please see the response to Exhibit I.STAFF.2.

ENBRIDGE GAS INC.

Answer to Interrogatory from
Pollution Probe ("PP")

INTERROGATORY

Question(s):

What low income energy program information was provided to homes and businesses along the proposed pipeline? Please provide copies.

Response

Please see the response to Exhibit I.PP.9.

ENBRIDGE GAS INC.

Answer to Interrogatory from
Pollution Probe ("PP")

INTERROGATORY

Question(s):

- a) Please provide a copy of all marketing and communication material provided by Enbridge or partners to the following stakeholders to promote DSM or other energy efficiency opportunities when considering renovation of a primary (water/space) heating systems:
- Municipalities and Indigenous communities
 - Consumers/businesses along the proposed route
 - Other forums including outreach events or the Virtual Information Session
 - Contractors that support the Hidden Valley area for HVAC and related home renovations
- b) Please provide a copy of all communication material provided by Enbridge or partners to educate the following stakeholders on options and incentives under the Greener Homes program (delivered by Enbridge in Ontario):
- Municipalities and Indigenous communities
 - Consumers/businesses along the proposed route
 - Other forums including outreach events or the Virtual Information Session
 - Contractors that support the Hidden Valley area for HVAC and related home renovations.

Response

- a) Please see the response to EB-2022-0249 Exhibit I.PP.8 part a).
- b) Please see the response to EB-2022-0249 Exhibit I.PP.8 part b).

ENBRIDGE GAS INC.

Answer to Interrogatory from
Pollution Probe (“PP”)

INTERROGATORY

References:

Figure 1: Annual Energy Costs & Savings Versus Natural Gas, Including SES
Figure 2: Annual Energy Costs & Savings Versus Natural Gas, Including SES (First Nations Communities)

Question(s):

- a) Please confirm that the values in Figures 1 and 2 relate to fuel only and do not include incremental equipment costs to retrofit a home or business with natural gas.
- b) Please provide the estimated cost per residential, commercial and industrial consumer to convert to a natural gas system, including required ducting or other related retrofits, if applicable.
- c) Please confirm that the values in Figures 1 and 2 relate to electricity are for electric baseboard heating only. If that is not correct, please state the assumptions.
- d) Please provide a list of the monthly non-commodity Enbridge bill costs (not including SES which is covered in Figures 1 and 2) that consumers will experience once on natural gas. If this differs for residential, seasonal and commercial consumers, please provide the information by each appropriate classification.

Response

- a) Confirmed.
- b) Per Enbridge Gas' current policy, the Company will provide and install at no cost, one service line per civic address to new customers, provided that the distance between the owner's property line and desired meter location is 30 metres or less. Services exceeding 30 metres will be billed at \$45 per metre plus applicable taxes.

Retrofit costs will vary substantially from customer to customer based on the equipment they are converting, the required retrofits, age of the home, fuel source, etc.

Enbridge Gas is not in the retrofit business and therefore all questions pertaining to retrofit and conversion costs beyond the natural gas meter should be directed to a licensed HVAC contractor of the customers' choosing.

- c) The annual bill for electricity in Figures 1 and 2 is for a typical residential customer and includes electric resistance space and water heating. All comparisons are based on the energy-equivalent annual consumption level of 2,200 m³/yr. Please refer to the response to Exhibit I.ED.1 part b), for the calculations and assumptions used to calculate the annual bill for electricity.
- d) A residential customer within the Union North-East zone (Rate 01) will incur a monthly charge of \$23.98 (as per the Company's April 2023 QRAM). This monthly charge is incurred by all natural gas customers, regardless whether they are seasonal customers or not. Commercial customers within the legacy Union Gas franchise who consume more than 50,000 m³ annually will incur a monthly charge of \$77.58. Commercial customers who consume less than 50,000 m³ annually will be billed at the equivalent residential rate of \$23.98. Please also see the response to Exhibit I.ED.1, part b), Attachment 2, Tab "Natural Gas Price (\$ per m³)" for a list of the Natural Gas costs included in Figures 1 and 2.

ENBRIDGE GAS INC.

Answer to Interrogatory from
Pollution Probe (“PP”)

INTERROGATORY

References:

Table 1: Estimated Annual Fuel Costs, Fuel Cost Savings & Payback Period for a Typical Rate 01 Residential Customer

Question(s):

- a) Please provide the information source for the annual bill estimates in Table 1.
- b) Please provide the equivalent to Table 1 for a typical commercial for this project.
- c) Please provide the equivalent to Table 1 for a typical industrial customer for this project.

Response

- a) Please refer to the response at Exhibit I.ED.1 part b).
- b) and c)
Enbridge Gas does not produce annual bill estimates for commercial/industrial customers. Quarterly charts of this nature are only prepared and available for residential customers. Finally, while the information set out in Table 1 is informative as to the economics of conversion to natural gas for residential customers, who represent the majority of Community Expansion project customers, the Project-specific attachment forecast is informed by direct survey information that represents current customer preferences with regard to energy sources for heating.

ENBRIDGE GAS INC.

Answer to Interrogatory from
Pollution Probe ("PP")

INTERROGATORY

References:

Exhibit A, Tab 2, Schedule 1 and Exhibit E (SES): Enbridge indicates that the System Expansion Surcharge ("SES") to all new customers taking gas distribution service from the Project will be a fixed volumetric rate of \$0.23 per cubic metre of gas to be charged in addition to Enbridge Gas's base distribution rates as approved by the OEB, in accordance with EB-2020-0094. The SES is proposed to be charged to all customers taking gas distribution service from the Project for a term of 40 years.

Question(s):

- a) The SES period of 40 years in EB-2020-0094 aligned with the amortization period of 40 years for distribution expansion projects. Please indicate the SES impact if the amortization period the OEB approves is different (either more or less) than 40 years.
- b) Please confirm that the same SES rate of \$0.23 per cubic metre applies equally to all proposed residential, commercial and industrial customers.
- c) Please explain why an Hourly Allocation Factor ("HAF") under EB-2022-0094 is not applied to any of the proposed commercial or industrial customers.

Response

- a) If the OEB approves a revenue horizon of greater than 40 years, it will require a shorter SES term to meet the Project Profitability Index ("PI") of 1.0. If the approved revenue horizon is less than 40 years, it will result in a PI to be less than 1.0 and make the project unfeasible.
- b) Confirmed. The SES rate will apply for up to 40 years for residential, commercial and industrial customers with less than 50,000 m³ per year. Customers who consume

more than 50,000 m³/year may elect to pay the SES or pay a contribution in aid of construction (“CIAC”) or use other contractual mechanisms to cover the revenue shortfall

- c) The Hourly Allocation Factor (“HAF”) provides a method for allocating the capital costs of a facility project between Large Volume Customers (“LVCs”) over time and is intended, in part, to address inequities that might arise from a single customer being allocated a disproportionate share of such costs. Moreover, most new customers forecast to attach are small volume residential and commercial customers that would not qualify for HAF as the minimum threshold for applicability is 50 m³/hr. Accordingly, the HAF is not a substitute for the SES and is generally not applicable to Community Expansion projects.

ENBRIDGE GAS INC.

Answer to Interrogatory from
Pollution Probe (“PP”)

INTERROGATORY

References:

Proposed Project Milestones [Exhibit B, Tab 1, Schedule 1, Page 9].

Question(s):

- a) What is the time window and cost related to the winter construction premium, compared to summer construction?
- b) Please explain why Enbridge is proposing winter construction rather than planning a construction period which avoids winter.
- c) Placing a pipeline into service in the fall (i.e. after September) does not provide the ability for customers to switch to natural gas equipment for space heating prior to the heating season. Please explain the impact if Enbridge constructed the project during the summer 2024 and placed the project into service late summer 2024.

Response

- a) and b)
Project rates will not have a winter construction premium based on the current schedule.

Weather can impact a construction schedule at any time of year. In instances of inclement weather conditions, the construction contractor may elect to cancel work for the day to avoid additional cost. The schedule for this Project is not considered winter construction, as it is anticipated that the majority of construction works would be completed prior to winter weather impacts, such as frost in the ground. The schedule was carefully selected to balance a variety of factors, including: (i) to minimize construction during conditions that incur winter premium costs; (ii) to adhere to applicable species at risk (“SAR”) timing windows to ensure compliance with the *Endangered Species Act, 2007*; and (iii) to coordinate with the community given other active/planned infrastructure projects.

- c) Customer services will be scheduled for installation as quickly as possible as applications to attach to the natural gas system are submitted/received. Due to the design of this system and the planned approach to construction and energization, some customers within scope may be able to connect to the system while natural gas main construction is still ongoing, prior to the start of the 2023/24 winter heating season. Customer outreach in this regard has already commenced within the community and will continue to enable Enbridge Gas to form plans for service installation as efficiently as is possible.

Based on the length of pipeline main(s) to be installed, construction will take approximately 6 months.¹ To delay construction to achieve a summer 2024 in-service date, construction would need to occur in the winter of 2023/24 exposing the Project to additional inflationary pressures, incremental winter construction costs, and resource challenges with the prime construction contractor (likely to be mobilized elsewhere within the province supporting other projects at that time). Alternatively, to accelerate or compress the construction schedule would require significant additional resources and associated additional costs.

Further, Enbridge Gas manages construction schedules and prime construction contractor resources at a program level, to maximize efficiency where possible. Given there are finite resources and materials available to support community expansion (“CE”) projects, any significant changes to a single CE project schedule, such as the one suggested by PP, are expected to lead to a cascading effect on other CE projects.

¹ Exhibit D, Tab 2, Schedule 1

ENBRIDGE GAS INC.

Answer to Interrogatory from
Pollution Probe ("PP")

INTERROGATORY

Question(s):

Please confirm that Enbridge will fund this project from its capital envelope for 2024 if approved by the OEB. If that is not correct, please clarify.

Response

Confirmed. Enbridge Gas has included the original forecasted capital cost and revenues in its 2024 Rate Rebasing application.

ENBRIDGE GAS INC.

Answer to Interrogatory from
Pollution Probe (“PP”)

INTERROGATORY

Question(s):

Please confirm what distribution and transmission systems this project will be fed by on a peak design day and please confirm what excess capacity those systems have to accommodate this project.

Response

The project will be fed by the Marysville Lateral which is supplied by TC Energy Corp. (“TCE”). This lateral has sufficient excess capacity to accommodate the proposed Project based on the forecasted attachments.

ENBRIDGE GAS INC.

Answer to Interrogatory from
Pollution Probe (“PP”)

INTERROGATORY

Question(s):

- a) What is the minimum number of residential and business customers that will need to attach to the proposed pipeline for it to remain feasible?
- b) Please explain what the financial implications are if less customers attach than are forecasted?

Response

- a) The customer attachment forecast for the Project is 166 residential customers and 13 commercial and industrial customers. Based on these customer attachments, the project PI is 1.0 and the NPV is \$3,000. As such, the minimum number of customers that will need to attach to the proposed pipeline for it to remain feasible is 166 residential customers and 13 business customers.¹
- b) If less customers attach to the Project than forecasted and actual revenues are lower than anticipated (as described at Exhibit E, Tab 1, Schedule 1, Attachment 2), there could potentially be a revenue deficiency for the Project. However, as described at Exhibit E, Tab 1, Schedule 1, and consistent with the OEB’s findings in its Decision and Order on the Company’s application for a System Expansion Surcharge, Temporary Connection Surcharge, and Hourly Allocation Factor (EB-2020-0094), upon placing the Project into service, Enbridge Gas will apply a 10-year Rate Stability Period (“RSP”) during which the Company will bear the risk associated with realizing the Project-specific customer attachment forecast.

¹ Or some other proportion of those customer types resulting in a similar revenue profile.

ENBRIDGE GAS INC.

Answer to Interrogatory from
Pollution Probe ("PP")

INTERROGATORY

Question(s):

- a) Please confirm that the amortization period for the proposed pipeline is 40 years. If that is incorrect, please provide the correct figure.
- b) Has Enbridge conducted a risk assessment on the probability that the proposed pipeline will become a stranded asset before being fully depreciated? If yes, please provide a copy of the assessment and all related materials. If no, what evidence exists to support that the pipeline will remain used and useful for the full amortization period.
- c) Please explain how any residual (unamortized) costs will be recovered from rate payers if the proposed pipeline becomes stranded before it is fully depreciated.

Response

- a) Confirmed.
- b) Enbridge Gas has no reasonable basis to believe that the proposed facilities will become stranded assets and thus has had no reason to complete the assessment in question.
- c) Please see response to part b) above.

From an accounting and regulatory perspective, Enbridge Gas applies group depreciation procedures to plant assets, including gas meters and distribution service lines. If the assets disconnected are retired before their expected average service life is reached (as reflected for the group), the implied loss is captured in accumulated depreciation. The loss would be reflected in subsequent depreciation studies and recovered through depreciation expense over the remaining life of the assets left within the group.

ENBRIDGE GAS INC.

Answer to Interrogatory from
Pollution Probe ("PP")

INTERROGATORY

Reference:

Exhibit E, Tab 1, Schedule 1, Table 1.

Question(s):

- a) Please provide details on the Ancillary Facilities.
- b) If the Ancillary Facilities are an essential requirement for the proposed Project, please explain why they are external to the Leave to Construct.
- c) Please explain why the Direct Overheads are greater for the Ancillary Facilities compared to the Project Costs, even though the Ancillary Facilities are less than $\frac{1}{4}$ the Project Costs.
- d) Please explain why this project does not include indirect capital overheads.

Response

- a) Please see the response to Exhibit I.ED.9, part b).
- b) The ancillary facilities described in part a) do not trigger the need for leave to construct approval as defined in Section 90(1) of the OEB Act.
- c) Please see the response to Exhibit I.STAFF.3 for an update to the Direct Overheads amount for Ancillary Facilities.
- d) Indirect O&M overheads are allocated to all capital projects that are considered to be 'core capital' from an Asset Management planning perspective. Core capital projects are included in the Asset Management Plan and are used to quantify the in-service capital spend for ICM determination during the MAADs deferred rebasing period. Community Expansion projects are not included in the capital spend for ICM purposes and are not part of the optimization process in the AMP. These projects

also have a specific approval and review process due to the 10-year rate stabilization period. For these reasons, indirect O&M overheads are not allocated to Community Expansion projects. Note that indirect overheads are also not allocated to other 'non-core' capital projects such as customer driven Compressed Natural Gas and Renewable Natural Gas.

ENBRIDGE GAS INC.

Answer to Interrogatory from
Pollution Probe (“PP”)

INTERROGATORY

Reference:

The cost estimate set out above differs from the amount estimated in the Company’s original project proposal to the Government of Ontario (2019/2020) for funding under Phase 2 of the NGEF by approximately \$1.5 million (EB-2019-0255). This cost variance is attributed primarily to the completion of Project design and schedule. [Exhibit E, Tab 1, Schedule 1, Page 1].

Question(s):

The NGEF subsidy is intended to bring a project to the minimum project threshold. Please explain how the subsidy is adequate is the project costs increased by approximately \$1.5 million compared to the application. If additional funding or revenues have been added since the NGEF application, please provide those details and the impact on the Profitability Index (PI).

Response

Please see the response to Exhibit I.STAFF.3, for a comparison of current Project costs to costs estimated in the Company’s original NGEF proposal.

Please also see the response to Exhibit I.STAFF.2 part h), for details regarding the additional customers included in the attachment forecast since the Company filed its original NGEF proposal.

The addition of incremental customers effectively offset the increase in Project costs realized since the Company’s original NGEF proposal. As a result,) despite there being no changes to the approved funding allocated to the Project, the projected Project PI remains 1.0.

ENBRIDGE GAS INC.

Answer to Interrogatory from
Pollution Probe (“PP”)

INTERROGATORY

Reference:

EGI_LTC Mohawks_Appl_F-1-1_Attachment 1_Redacted_20221220 Appendix L.

Question(s):

- a) Most of the entries in the Consultation Log indicate that Enbridge (or its agents) did not receive feedback based on local outreach. Please indicate what actions were taken to mitigate this communication gap, if any.
- b) Is there a Consultation Log for non-Indigenous consultation feedback. If yes, please provide a copy.

Response

- a) There is no communication gap. Enbridge Gas engaged as early as possible, openly sharing all relevant and required Project-specific information with all potentially affected nations identified by the Ministry of Energy (“ENERGY”). Representatives of those same nations stated either by phone or email that they do not intend to comment on works taking place on another band’s territory. Enbridge Gas is continuing to engage and consult on the Project with the Mohawks of the Bay of Quinte and will continue to inform, engage and consult with all other nations identified by ENERGY according to their specific interest and identified concerns going forward.
- b) Appendix F in the Environmental Report includes a log of non-Indigenous consultation.¹ Please also see the response to Exhibit I.ED.2, Attachment 2, for an updated Municipal Consultation Log.

¹ Exhibit F, Tab 1, Schedule 1, Attachment 1, Appendix F

ENBRIDGE GAS INC.

Answer to Interrogatory from
Pollution Probe (“PP”)

INTERROGATORY

Question(s):

The Environmental Report identified significant wildlife habitat, breeding and nesting zones along the proposed route. Please provide the mitigation measures Enbridge will put in place during construction and restoration to mitigate impacts.

Response

Please refer to section 6.0 Effects Assessment and Proposed Mitigation of the Environmental Report for suggested mitigation measures for significant wildlife habitat and breeding and nesting zones.¹ Additional mitigation measures will be developed as necessary as part of ongoing engagement and discussion with Indigenous communities and consultation with regulatory authorities during the permitting process.

¹ Exhibit F, Tab 1, Schedule 1, Attachment 1

ENBRIDGE GAS INC.

Answer to Interrogatory from
Pollution Probe (“PP”)

INTERROGATORY

Question(s):

Please provide a copy of the detailed mitigation plan for the proposed pipeline.

Response

Work to develop Project-specific mitigation plans, which is detailed in section 6.0 Effects Assessment and Proposed Mitigation of the Environmental Report, is currently ongoing. Please refer to the response to Exhibit I.PP.21, for discussion regarding additional mitigation measures.

ENBRIDGE GAS INC.

Answer to Interrogatory from
Pollution Probe (“PP”)

INTERROGATORY

Question(s):

Please confirm that Enbridge will implement all “Recommended Mitigation and Protective Measures” included in the Dillon Consulting Ltd. (“Dillon”) Environmental Report.

Response

Not confirmed. Please see the response to Exhibit I.PP.21. Enbridge Gas will consider all mitigation measures included in the Environmental Report, which will be refined prior to construction based on continuous engagement and discussion with Indigenous communities, field studies, and in consultation with regulatory authorities. Enbridge Gas will adhere to the Environmental Protection Plan (“EPP”), which is developed once all environmental permits and approvals have been obtained, for the specific measures required for the Project.

ENBRIDGE GAS INC.

Answer to Interrogatory from
Pollution Probe (“PP”)

INTERROGATORY

Reference:

Project Schedule [Exhibit D, Tab 2, Schedule 1]

Question(s):

The project schedule document looks like to was truncated when it was cut and paste into the application and does not include additional activities such as project restoration and clean-up. Please provide the complete schedule including post in-service activities. Please provide any schedule updates in the revision, to the extent they exist.

Response

As stated in pre-filed evidence at Exhibit B, Tab 1, Schedule 1, page 9:

Inspection and restoration will be completed as the Project is installed. Any additional clean-up activities (in case required) would resume in the spring of 2024.

Other post in-service activities will be reliant upon the OEB’s Conditions of Approval for the Project.